

Computer aided
process planning
for high-speed milling
of thin-walled parts

Strategy-based support

Michiel Popma

COMPUTER AIDED PROCESS PLANNING FOR HIGH-SPEED MILLING OF THIN-WALLED PARTS STRATEGY-BASED SUPPORT

PROEFSCHRIFT

ter verkrijging van
de graad van doctor aan de Universiteit Twente,
op gezag van de rector magnificus,
prof.dr. H. Brinksma,
volgens besluit van het College voor Promoties
in het openbaar te verdedigen
op woensdag 2 juni 2010 om 15.00 uur

door

Michiel Gijsbrecht Roeland Popma
geboren op 5 mei 1974
te Nijmegen

Dit proefschrift is goedgekeurd door de promotor Prof. Dr. Ir. F.J.A.M. van Houten.

Computer Aided Process Planning for High-Speed Milling of Thin-Walled Parts Strategy-Based Support

PHD THESIS

by Michiel Popma at the Department of Engineering Technology (CTW) of the University of Twente, Enschede, the Netherlands.

Enschede, April 2010

Samenstelling van de promotiecommissie:

Prof. Dr. F. Eising	Universiteit Twente, voorzitter/secretaris
Prof. Dr. Ir. F.J.A.M. van Houten	Universiteit Twente, promotor
Prof. Dr. Ir. R. Akkerman	Universiteit Twente
Prof. Dr. Ir. J. Huétink	Universiteit Twente
Prof. Dr. Ir. B. Lauwers	Katholieke Universiteit Leuven
Prof. Dr. Ir. M.J.L. van Tooren	Technische Universiteit Delft
Prof.Dr.-Ing. Dr.-Ing.E.h. Dr.h.c. F. Klocke	RWTH Aachen University
Dr. Ir. A.H. van 't Erve	Siemens PLM Software

Keywords: Computer-aided process planning, high-speed milling, thin geometry

ISBN 978-90-365-3040-8

Copyright ©2010 Michiel Popma

Cover image by Lars Sundström, licensed under the RGBStock.com license.

Cover design by Michiel Popma

Printed by Gildeprint Drukkerijen, Enschede, the Netherlands

This work has been typeset using L^AT_EX.

Summary

Technological developments have made high-speed milling economically attractive. It is now a manufacturing technology that can competitively manufacture thin-walled parts. Such parts however can require a lot of material to be machined. With high-speed milling, this can take a lot of toolpaths. Process planning such products is difficult and time-consuming due to the vast amount of paths to program and the low stiffness of the final part. The workpiece at one point becomes the weakest element during machining, and its stiffness properties change as machining progresses. This thesis presents an error avoidance based approach for computer aided process planning for these parts, to help automate process planning and make it more reliable.

The core of process planning thin-walled parts is ensuring that thin workpiece geometry is sufficiently supported at the point of machining. In the approach in this thesis, the support comes from remaining workpiece material. This makes the order of material removal crucial. Material removal strategies can be needed on different levels, depending on the scope of the thinness, and can differ for different shapes. This support-based planning has therefore been detailed differently on different levels, in a feature-based, knowledge-based form. To separate stiffness issues from (high-speed) machining process issues where possible, stiffness features are introduced in addition to machining features. Nevertheless, particularly on the level of volumes to remove, a degree of interaction remains between stiffness considerations and machining considerations.

Due to the nature of the parts and the process planning approach - process planning based on the above described support principle requires control over more or less the whole workpiece - manufacturing strategies need to consider a larger environment than in traditional milling. This makes the strategies and the knowledge to apply more complex. Therefore, it becomes considerably more difficult to increase the level of automation.

The approach and concepts have been implemented into software, based on an existing feature-based, knowledge-based CAPP package. The core steps of planning the volumes to remove, how to machine them, and in which order, have been automated in a knowledge-based way. Also supplementary software utilities and functionality have been implemented. From evaluation of the resulting application for industrial practice, the automatic determination of the machining sequence for thin-walled geometry and the improved overview of the process plan were considered great benefits.

Samenvatting

Door technologische ontwikkelingen is hogesnelheidsfrezen economisch gezien aantrekkelijk geworden. Het is tegenwoordig een fabricagetechnologie die concurrerend dunwandige onderdelen kan fabriceren. Bij zulke onderdelen moet echter vaak veel materiaal worden verspaand en met hogesnelheidsfrezen vergt dit veel gereedschapsbanen. Werkvoorbereiding van dergelijke producten is lastig en tijdrovend vanwege de grote hoeveelheid te programmeren gereedschapsbanen en de lage stijfheid van het eindproduct. Het werkstuk wordt op een gegeven moment het meest kwetsbare element tijdens het verspanen en zijn stijfheidseigenschappen veranderen gedurende het bewerkingsproces. Dit proefschrift beschrijft een benadering voor computer ondersteunde werkvoorbereiding voor dit soort onderdelen, ten bate van automatisering en betrouwbaarheid van de werkvoorbereiding.

De essentie van werkvoorbereiding voor dunwandige onderdelen is garanderen dat dunne werkstukgeometrie voldoende wordt ondersteund op plaats en moment van bewerking. In de benadering die dit proefschrift behandelt, wordt deze ondersteuning gegeven door werkstukmateriaal dat nog niet is verspaand. Hierdoor wordt de volgorde van werken, d.w.z. van materiaal verwijderen, cruciaal. Strategieën hiervoor kunnen nodig zijn op verschillende niveaus, afhankelijk van de mate van dunwandigheid, en kunnen variëren voor verschillende vormen. De op ondersteuning gebaseerde planning is daarom op verschillende manieren uitgewerkt voor diverse niveaus, in een feature- en kennisgebaseerde vorm. Om zoveel mogelijk stijfheidskwesties te scheiden van kwesties gerelateerd aan het (hogesnelheids)verspaningsproces, zijn stijfheidsfeatures geïntroduceerd, in aanvulling op het bestaande concept van bewerkingsfeatures. Desondanks blijft er overigens, met name op het niveau van te verwijderen volumes, sprake van een mate van interactie tussen stijfheidsoverwegingen en operatie-overwegingen.

Vanwege de aard van de onderdelen en de werkvoorbereidingsaanpak is het nodig dat bewerkingsstrategieën een grotere omgeving in aanmerking nemen dan bij traditioneel frezen. Werkvoorbereiding op basis van het hierboven beschreven ondersteuningsprincipe vereist immers dat min of meer het hele werkstuk onder controle moet worden gehouden. Hierdoor worden de toe te passen strategieën en kennis complexer. Derhalve wordt het beduidend moeilijker om de automatiseringsgraad te verhogen.

De aanpak en concepten zijn omgezet in een software-implementatie, gebaseerd op een bestaand feature- en kennisgebaseerd CAPP software-pakket. De kerntaken, het plannen van de te verwijderen volumes, hoe ze te verspanen, en in welke volgorde,

zijn op een kennisgebaseerde manier geautomatiseerd. Daarnaast zijn er aanvullende hulpmiddelen en functionaliteit geïmplementeerd in de software. Uit evaluatie van de resulterende applicatie voor de praktijk bleek, dat de automatische bepaling van de bewerkingsvolgorde voor dunwandige geometrie en het verbeterde overzicht over het bewerkingplan werden gezien als belangrijke winstpunten.

Preface

Probably I myself was the last person who thought I would get a PhD. When the project on which this thesis is based started, it was an independent, challenging, scientific assignment, which I was eager to take on. The possibility to obtain a PhD on the research and development presented itself to me later, and took some convincing from my supervisors. So in a way, they are really to blame. But this manuscript is not the only fruit harvested from this period. I learned a lot during the project, like coding properly, or that there are many reasons for bringing cake that just can't be denied, to name just a few.

None of this may have happened if the opportunity to do this project hadn't been pointed out to me by my MSc supervisor, Otto Salomons, whom I'd like to thank also for supervising and aiding me in the first phases of the project. Also, the people at Fokker Aerostructures were supportive and cooperative from the very start. So, for their confidence, but also for their valuable feedback, I'd like to thank Jan Wubs and Rob Salomons. For the realisation of this thesis, I owe a lot to my supervisor, Professor Van Houten. His input in our many discussions was always keen and sharp. Also researchers need a sounding board. More on the development side, Tom van 't Erve and Theo Balkenende from (then) Tecnomatix Machining Automation acted as one for me. I also had valuable 'accomplices' in the MSc students that worked on the project; Joost Andringa, Gijs Hagen and Gijs van Ouwkerk. Their input, contributions and company were much appreciated. But also other team members, Hartwin Lier, Michiel Post, Frank Reimering and Maurits Hol, helped tremendously to put those weird ideas of mine into working software.

For the larger part of the project, I spent my working hours in the Tecnomatix office just across the street from the University. I truly enjoyed working alongside the Tecnomatix employees, who treated me as a colleague despite the fact that I was just 'visiting'. The humorous conversations and remarks during and in between breaks ("En wat zeggen we dan tegen de ...") were at times hilarious and were among the reasons that made me enjoy coming to work. I am glad I got the chance to stick around.

Although the path wasn't easy, I have sincerely enjoyed working on this project. A challenging job together with people that are a pleasure to work with go a long way. But just as important is the home front. I am truly grateful to my parents and my brothers for their love and support, especially when I needed it the most. Finally, thanks for everything to Susanne. It is probably safe to say that this thesis wouldn't be here without you. This thesis may not be your cup of tea, but you certainly understand me.

Michiel

Contents

Summary	v
Samenvatting	vii
Preface	ix
1 Introduction	1
1.1 An introduction to high-speed machining	1
1.2 Thin-walled parts	4
1.3 Domain-specific issues in process planning	5
1.4 Computer-aided process planning	7
1.5 Objectives	8
2 Related work	11
2.1 Process-related research	11
2.1.1 High-speed machining history	11
2.1.2 Material aspects of high-speed machining	12
2.1.3 Dynamics and deflection	13
2.2 Machining practices	17
2.2.1 High-speed milling	17
2.2.2 Thin-walled geometry	21
2.3 Computer-aided process planning	26
2.3.1 Process planning	26
2.3.2 Computer support approaches	27
2.3.3 Form features	27
2.3.4 Knowledge-based support	29

2.3.5	Work by the Design, Production and Management research group	29
2.4	Computer support for planning high-speed machining	31
3	Process planning thin-walled parts for high-speed milling	35
3.1	Accuracy	35
3.1.1	Accuracy in milling	35
3.1.2	Implications for high-speed milling of thin-walled parts	37
3.1.3	Predictability	38
3.1.4	Prevention	39
3.1.5	Consequences for process planning	42
3.2	Reviewing the task division in process planning for thin-walled parts	42
3.2.1	Traditional generative process planning	43
3.2.2	General approaches to process planning issues for thin parts	44
3.2.3	The role of strategies and their scope	45
3.2.4	A process planning task division for HSM for thin-walled parts	49
3.2.5	The role of knowledge	52
4	Manufacturing strategy knowledge for thin parts	53
4.1	Strategies on feature level	53
4.1.1	The step approach	54
4.1.2	Stiffness knowledge	55
4.1.3	Manufacturing knowledge	61
4.1.4	Expressing knowledge	67
4.2	Strategies on product level	70
4.2.1	Stiffness feature sequence	70
4.2.2	Knowledge examples	71
4.2.3	Expressing knowledge	71
4.3	Strategies on tool path level	72
4.3.1	Combining finishing and roughing	72
4.3.2	Tool path and cutting condition demands	73
4.3.3	Demand consequences	76
4.3.4	Modular tool paths	78
4.3.5	Region subdivision criteria	80

5	Application design	81
5.1	Envisioned process planning workflow	81
5.2	Reference data structure	83
5.3	Design of strategy-based tasks	84
5.3.1	Machining feature determination	84
5.3.2	Stiffness feature sequence constraint determination	85
5.3.3	Machining operation computation	87
5.4	Design of supporting tasks	94
5.4.1	Structural product data interpretation	94
5.4.2	Modification of machining features	97
5.4.3	Sequence-related and accessibility-related tasks	101
6	Application development	107
6.1	Product model interpretation	107
6.1.1	Stiffness feature recognition	108
6.1.2	Connection determination	108
6.1.3	Stiffness feature accessibility	109
6.2	Planning intermediate workpiece states	109
6.2.1	Stiffness feature sequence constraint determination	109
6.2.2	Machining feature determination	110
6.2.3	Tools for modification of machining features	112
6.2.4	Tools for reviewing feature relations	115
6.3	Operation determination	115
6.3.1	Architecture - controlling modular tool paths	115
6.3.2	Generating modular tool paths	116
6.3.3	Steering modular tool paths - knowledge	120
6.3.4	Cutting conditions	121
7	Results	123
7.1	An example process planning user session	123
7.2	Practical usage and evaluation	131

8 Advances in thin wall manufacturing	135
8.1 Machining of thin-walled parts	135
8.2 Process planning for high-speed machining and thin-walled parts	138
9 Conclusions	141
9.1 Conclusions	141
9.2 Recommendations	144
Bibliography	146
A Machining feature sizing	153
A.1 Milling tests	153
A.2 Model parameters	161

Chapter 1

Introduction

The work in this thesis is the result of a project initiated by Fokker Aerostructures. They use high-speed machining (HSM) to manufacture thin-walled, integral parts, meant to replace sheet-metal assemblies. The manufacturing technology and the type of parts make the process planning different, more intricate and more time-consuming when compared to traditional machining. In their opinion, it should be possible to improve and speed up the specific planning for this application area by more computer support and automation. The project has been a co-operation between Fokker Aerostructures, the University of Twente and Tecnomatix Machining Automation.¹

The following subsections subsequently introduce high-speed machining and machining of thin-walled parts, and discuss process planning of such parts at Fokker Aerostructures. Then a brief description is given of the Tecnomatix Machining Automation's computer-aided process planning software, which served as a basis of the project's development work. Finally, the objectives of the project are described.

1.1 An introduction to high-speed machining

High-speed machining is perhaps best introduced by listing the most general and characteristic differences of the machining process when compared to common machining. Material removal rates, feeds and cutting speeds are typically high. Cutting forces are low, which is partially influenced by the low depths of cut that are often used (both axial and radial [Tlustý 1993]). Furthermore, there is only little heating up of the workpiece. [Hurk 1998], [Korte 1998]

High-speed machining is especially applied to light metal alloys. According to Schulz and Moriwaki, high-speed machining is suitable for both roughing and finishing of light metal alloys, non-ferrous metals and plastics, and for finishing of steel, cast iron and difficult-to-cut alloys [Schulz & Moriwaki 1992].

¹In 2005, UGS Corp acquired Tecnomatix Technologies Ltd. In 2007, UGS was acquired by Siemens. Named Siemens PLM Software, it is now a Siemens division.

What is high-speed machining?

In literature, the definitions of high-speed machining are many. As observed in [Hurk 1998], existing definitions are based on among other things spindle speeds, cutting speeds or machining dynamics.

A definition based on spindle speed is not adequate, as cutting speed depends on the combination of spindle speed and mill diameter. Defining spindle speed ranges as high-speed ranges is therefore very ambiguous.

Nevertheless, cutting speeds are also questionable as a standard. This has also to do with the fact that with time, higher machining speeds have become possible. At first, when higher speeds became possible, terms such as super high-speed machining and ultra high-speed machining were introduced [King 1985]. The trend of rising cutting speeds and feed rates has not yet ended, so this is not such a good criterion for a definition. Moreover, which cutting speed range is considered as a high-speed milling range depends on the workpiece material (see figure 1.1).

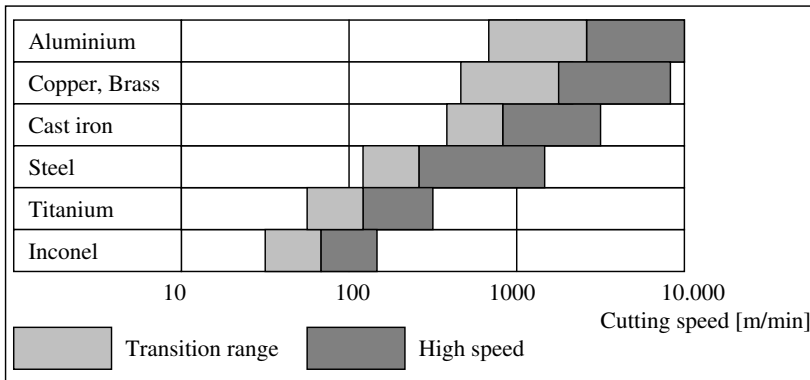

Figure 1.1: Common cutting speeds for several workpiece materials, after [Hurk 1998].

Smith, from the University of Florida, gives a completely different definition of high-speed machining [Hurk 1998]:

”One speaks of high-speed machining when the tooth passing frequency of the tool approaches the natural frequency of the machine-tool system.”

The tooth passing frequency refers to the frequency with which the tool flutes 'hit' the workpiece material. The machine-tool system comprises the machine, the spindle, the tool etcetera, and the workpiece.

In [Kaldos et al. 1996], it is stated that as cutting speeds increase above the conventional feed range, new dynamic effects are encountered in the cutting process, e.g. change of the basic chip morphology. However, later research indicates that cutting

speed does not necessarily cause this and that the state of the material can play a large role in this effect [Schulz et al. 2001]. So, a large change in chip morphology, e.g. from continuous to grossly serrated, is not a good criterion.

The most convenient definition seems to be the relative one adopted by the PTW institute², which is related to cutting speed. Salomon's fundamental research (see section 2.1.1) showed that there is a certain range of cutting speeds where machining is not possible due to high temperatures. When cutting speeds beyond that limit are used, this can be termed high-speed machining. In compliance with modern knowledge, the PTW institute defines high-speed machining as being such that conventional cutting speeds are exceeded by a factor 5 to 10. [Schulz 1999]

Advantages and disadvantages

The advantages of high-speed milling mentioned in literature are numerous [Agba et al. 1999] [Hurk 1998] [Kaldos et al. 1996] [Korte 1998] [MMSonline] [Schulz & Moriwaki 1992] [Smith & Dvorak 1998] [Zander 1998]. The most relevant will be listed here.

- Reduced machining time (up to 50%), increased metal removal rates;
- Equally good or better product quality when compared to traditional milling:
 - Better surface finish;
 - Better form and dimensional accuracy, especially in the machining of thin webs due to reduced chip load;
- The possibility to machine thin-walled sections, which offers the possibility of manufacturing monolithic components instead of sheet metal sub-assemblies;
- Low cutting forces, which offers an effective way to use small, delicate tools;
- Very little heating up of the workpiece; the generated heat ends up in the chips, resulting in a cooler workzone;
- Reduced burr formation;
- Better chip disposal;
- Simplified fixturing;
- High-speed machining can be used for hard materials;
- The possibility of dry milling of cast iron and aluminium workpieces. The need for coolant is reduced due to the cooler workzone.

²Institute of Production Engineering and Machine Tools, Darmstadt University of Technology, Germany.

The drawbacks of high-speed machining are far less discussed in literature. The main disadvantages and limitations are given below.

- The costs of machinery, controllers, spindles and tooling are higher [Agba et al. 1999]. Requirements imposed on these components are higher than for traditional machining, e.g. high stiffness and the capability of achieving high accelerations.
- Tool wear is high (depending on workpiece material) [Agba et al. 1999]. In machining of difficult-to-machine materials, e.g. titanium, this limits the cutting speed [Schulz & Moriwaki 1992].
- The need for modification of tool paths and machining techniques as compared to traditional machining practices [Agba et al. 1999].
- The lower stability of machining when manufacturing thin-walled components due to low workpiece stiffness, which makes chatter more likely to occur as well as more disastrous [Smith & Dvorak 1998].
- According to Tlusty, process damping is negligible in high-speed machining [Tlusty 1986] [Tlusty 1993], which is disadvantageous for the stability of the machining process.
- Process planning is often far more laborious than for traditional milling. Large amounts of NC code need to be generated.

1.2 Thin-walled parts

In [Schulz & Moriwaki 1992], table 1.1 is presented, which gives a good indication of the application areas for high-speed machining.

The application areas which are most often discussed in literature, are die and mould manufacturing and machining of thin-walled products (mostly aircraft and aerospace industry). Such thin-walled products are often large, integral products, for which typically up to 95% of the blank is machined [Hurk 1998], or even more.

Machining monolithic components instead of manufacturing sheet metal sub-assemblies provides the following advantages:

- The thin-walled monoliths are functionally equivalent or stronger, less expensive, possibly lighter and more accurate components [Smith & Dvorak 1998].
- Inventoried components are reduced, component assembly operations, jigs and fixtures are eliminated and downstream assembly time is reduced, which causes relative cheapness of the monolithic components [Smith & Dvorak 1998], [Hurk 1998].
- Lead times are reduced (no separate part production) [Hurk 1998].

Technological advantage	Application field	Application examples
Big cutting volume / time	Light metal alloys, Steel and cast iron	Aircraft/aerospace products, Tool/die mould manufacture
High surface quality	Precision machining, Special workpieces	Optical industry, fine mechanical parts, Spiral compressors
Low cutting forces	Processing of thin-walled workpieces	Aircraft/aerospace industry, automotive industry, household equipment
High frequencies of excitation	No machining in critical frequencies	Precision mechanics and optical industry
Cutting heat transport by the chips	Machining of workpieces with critical heat influence	Precision mechanics, Magnesium alloys

Table 1.1: Application areas for high-speed machining, after [Schulz & Moriwaki 1992]

In theory, low cutting forces can also be achieved at with conventional cutting conditions. However, high-speed machining is needed to achieve the material removal rate that provides the lead times and costs that can compete with sheet metal based production.

Various research has been performed on machining of thin-walled parts (see chapter 2). However, not all this research involved high-speed machining as well. Nevertheless, similar problems can occur for both traditional and high-speed machining. Some important considerations on machining thin-walled workpieces:

- At a certain point in machining a thin rib, the rib becomes more flexible than the tool [Tlustý et al. 1996].
- When milling up, thin workpieces have the tendency to chatter due to alternately pulling up and pushing down of the workpiece [Streppel 1983].
- When milling down, thin workpieces are far less sensitive to chatter, as they are constantly pushed down by the mill. On the other hand, too thin workpieces may deflect. [Streppel 1983]

1.3 Domain-specific issues in process planning

Figure 1.2 and table 1.2 give a notion of the kind of parts that Fokker Aerostructures manufactures. The thin-walled nature of the products has a high impact on their process planning. The key word in this is stiffness. Process planners constantly need to keep the state of the product in mind with respect to stiffness, locally and globally, despite the low cutting forces that high-speed machining is known for.

At Fokker Aerostructures, the products are manufactured in vertical set-ups. Furthermore, a piece of the blank that will not be machined is clamped. Thus, the entire

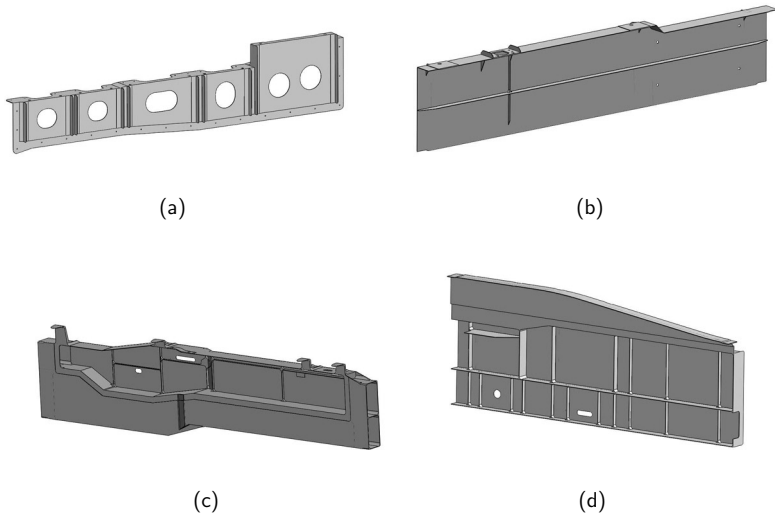

Figure 1.2: Fokker Aerostructures thin-walled high-speed milling product examples

product is above the clamps. The last step for a part is milling it loose from this piece of the blank, so that only thin walls remain.

Dimension	Size range (mm)
Length	1000 - 1700
Height	400 - 900
Depth	100 - 150
Wall thickness	1.1 is quite common
Tolerances	0.1 often maintained for entire product
Hole tolerances	0.03 sometimes used

Table 1.2: Common sizes for Fokker Aerostructures high-speed machining products

From figure 1.2 and table 1.2, one can see that tool paths to machine these parts can become quite long. High-speed machining generally uses lighter cutter immersions, when finishing usually combined with down milling (see chapter 2). This changes the ratio between cutting motions and non-cutting motions. To keep non-cutting time low, either non-cutting motions should be fast or process planning should try to minimise them.

Features are shapes with engineering meaning. Traditional milling parts, like the part shown in figure 1.3(a), are typically viewed in terms of depression features such as holes and pockets. As mentioned, the process planners at Fokker Aerostructures constantly need to think of the global and local stiffness of thin parts like the one shown in figure

1.3(b). Consequently, they think in terms of walls, ears and the like, i.e. more or less in terms of 'stiffness' features. Such protrusion features therefore seem far more important than depression features. When process planning a seemingly simple pocket of a thin part, the process planner thinks about 'the other side of the wall' - is it still thick, et cetera. This is a very important mindshift in comparison with traditional milling. In general, process planners will not be purely concerned with individual features, but with the product as a whole. When determining a manufacturing method, they will hardly ever look at a sole feature; they need to look over the boundaries of features.

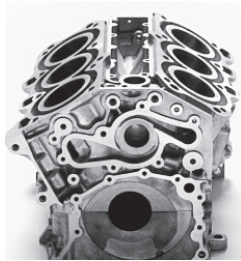

(a) *An engine block*

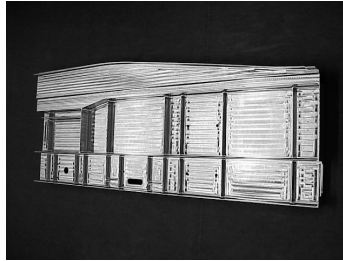

(b) *A thin-walled aerospace part*

Figure 1.3: Thin-walled parts are viewed differently in machining from traditional parts.

So, first, up to 99% of the original blank volume is machined for a product. Second, the thin-walled nature of the products requires special - unconventional - machining approaches. Third, the computer tools that the process planners had at their disposal when this project started are in fact CAM-tools. They support mostly the interactive (semi-automatic) creation and editing of operations and tool paths. The algorithms supplied by these tools are not aimed at high-speed milling of thin products. Verification of the tool paths, by simulation, takes place using another software tool. The combination of these factors makes the process planning of these products a laborious task and therefore a lead-time bottleneck. The large set of paths makes it hard to keep the overview on a process plan. This makes this task error-prone as well.

The effort needed for the programming and verification of the process plan also has as a consequence that when a plan results in a proper product, it will generally not be adapted, because that may again take a rather large effort. So, once they work, process plans will hardly ever be optimised.

1.4 Computer-aided process planning

The PART process planning software, which will be described in section 2.3.5, was taken from academic computer-aided process planning software to a commercially available system. Tecnomatix Machining Automation has been responsible for this software, which

was later renamed to *eMPower Machining*. A next generation version of this software has been built under the name of *eMPower Advanced Machining* (which was later renamed to *Machining Line Planner*).

As starting input, 3D CAD model data in common formats like STEP, IGES, Catia, Pro/Engineer, ACIS and Parasolid are supported. The software offers the extendable feature recognition and machining method and tool selection described in section 2.3.5, and provides over 120 feature types out of the box. Through a customizable resource environment, operation determination can reason with customer-specific machine, tooling, fixturing and material information. Even tool path motions can be customised, as well as machining parameters for cutting condition calculation. In the area of optimisation, it offers cycle time calculation, and line balancing and sequencing that considers relevant constraints and tries to minimize non-machining time, by trying to avoid tool changes, table rotations and tool travel. Other features are automated design change management, planning product variants and simulation of operations. [Siemens PLM Software 2009]

1.5 Objectives

Both the difficulty and the time-consuming nature of the process planning task for high-speed milling were cause to initiate this project. The main task of the project has been formulated as follows:

”The development of an automatic and generative process planning system for the process planning of thin-walled products that are to be manufactured by means of high-speed milling.”

This development needs to take on the problems that one is faced with when process planning for high-speed milling for thin-walled products:

- Process planning is now a lead-time bottleneck and thus needs to be speeded up.
- Process planning software should provide for concepts, strategies and tools that are fit for the job. Besides automation, the software should make the task easier to perform. This will help speeding up process planning.
- Resulting process plans will result in vast amounts of tool paths. The process planning software should give a user better overview. It should provide handles that show a process planner where his current editing fits in the total process plan.
- Concepts and tooling should also be devised in such a way that adaptation of the process plan, due to product changes or for efficiency, is easier to perform.
- Technologically speaking, the thin-walled nature of the product - or rather the problems that it introduces - is the main issue that the process planning system must deal with. The thinness requires process planning using a different view on

the geometry, but also a different scope. As a product as a whole can be thin-walled, some technological decisions should be made on product level instead of locally. Stiffness is an essential concept.

- High-speed milling also introduces technological differences when compared to traditional milling. Especially when applied to thin product machining, there are other issues in the process that require the focus of attention.

The result of the process planning software must be of good quality, meaning that the plans should deliver sufficiently accurate parts. In order to do so, the system must be able to deal with the consequences of the thin-walled nature of the part during process planning, especially low workpiece stiffness. It should be capable of handling 2.5D geometry, to be machined using (at least) 3-axis machining. It should be capable of handling at least aluminium as workpiece material. Optimisation of the process plans was considered desirable, but not required. Qualitatively good process plans were considered more important. The software described in section 1.4 provides a basis for the development.

Chapter 2

Related work

This chapter discusses the state of affairs in relevant areas as found in literature in the early phases of the project. Subjects of interest are research on machining thin geometry and high-speed machining, machining practices in these areas, and related computer support.

2.1 Process-related research

The following subsections will discuss research of interest regarding the machining process. A brief historical overview will be followed by a discussion of aspects related to workpiece material, and dynamics and deflection, respectively.

2.1.1 High-speed machining history

Jablonowski provides a rather comprehensive overview of high-speed machining research history in [Jablonowski 1990], which will be summarized here.

The German scientist Carl J. Salomon is generally regarded as the father of high-speed machining. He conducted a series of experiments concerning high-speed machining in the period 1924 to 1931, and got a patent around this work. He argued that cutting temperatures rose with increasing cutting speed up to a critical peak. Beyond that peak, which occurred at the so-called critical speed, cutting temperatures would drop - and tool life would improve - with further increase of speed. Different temperature/speed curves were thought to apply to different workpiece materials. Salomon's research group developed and extrapolated curves for different workpiece metals, but unfortunately most of the developed data was lost during the Second World War.

After this, there was a period where there was little scientific attention for high-speed machining, although individual cases from industrial practice are known. One of those is that starting in the late 1940s, Fokker BV started using spindle speeds of 18000 to 24000 rpm for small-diameter cutters to machine aluminium sheet at 16.5 m/s.

Serious scientific developments only started again in the late 1950s, when Lockheed engineer Robert L. Vaughan discovered Salomon's work. His research group tried to duplicate the research, but also to take the process to extremely high speeds to gain insight into the phenomena occurring inside the workpiece material. To this end, they resorted to 'ballistic machining': taking a gun and firing simulated workpieces past a single-point tool. This remarkable approach is explained by the fact that the group's main goal was data gathering, not devising production methods.

Again, major scientific development in the area were on hold until in the 1970s, when research on chip formation in high-speed machining was carried out. This research, directed by Robert I. King, also focussed for a part upon making high-speed machining a production technology.

In the 1980s, several consortia were set up in which universities and industrial firms cooperated. In their work, focus shifts even more to actual application of the technology. Since then, commercial interest and with that academic interest in the area has grown significantly.

2.1.2 Material aspects of high-speed machining

The cutting speed range which is considered as high-speed machining depends on the workpiece material. High-speed machining theory must in general be differentiated to workpiece material [Zander 1998]. Namely, when increasing cutting speed, different phenomena occur when machining different types of workpiece material, in which different kinds of chips are formed [Schulz & Spur 1989]. For example, cutting forces decrease far less for brittle materials (built-up edge chip forming) than for ductile materials (continuous chip forming); this can be explained by the occurring phenomena.

Often encountered phenomena are an increase of power consumed at the cutting edge, a decrease of cutting forces, a decrease of the temperature of the workpiece and an increase of the temperature of the chip and the tool rake face. The latter phenomenon implies that the generated heat has no time to heat up the workpiece. [Popma 2000]

[Schulz & Spur 1989] describes the different effects in high-speed machining different materials, including ductile materials like aluminium. For ductile materials, the chip formation process can be divided into two parts:

1. Plastic deformation and subsequently shearing in the area of the shear plane;
2. Friction due to the relative movement between the chip and the tool rake face of the cutter.

There are two models for shear; one based on a shear plane and one based on a shear zone. At high cutting speeds, the shear zone in fact turns into a plane.

The most relevant phenomena at high cutting speeds for ductile materials are:

- The strain hardening and the width of the contact zone are reduced. Consequences are a greater shear angle, which gives more chip curvature and allows for better chip disposal (chip flow). This results in lower cutting forces and less deformation work.
- The temperature in the contact zone increases greatly, but the amount of heat generated in the shear zone is less due to the lighter cutting (better chip disposal). This results in a relatively cold workpiece, but tool wear increases due to the high temperature. The generated heat ends up in the chips, which is advantageous.

Because the chips are hot, it is desirable to reduce contact between these chips and the workpiece. In this respect, vertical machining setups are better than horizontal setups.

Serrated chip forming mostly occurs for highly alloyed workpiece materials; it occurs more extremely for materials that conduct heat badly. Later research showed that the material microstructure, and thus heat treatment, can play a strong role in changes in chip formation. Experiments for an aluminium alloy described in [Schulz et al. 2001] showed, that the microstructure has a dominating influence on chip formation in high-speed machining. Schulz et al. concluded that continuous or segmented chip formation was largely determined by the microstructural properties of the workpiece material, whereas machining parameters such as cutting speed and feed per tooth only determined the degree of segmentation.

2.1.3 Dynamics and deflection

Vibrations are a relevant issue in machining, as they can form a process limitation. They can result in reduced accuracy and surface quality, and increased wear of tooling. Vibrations can be free, forced or self-excited (regenerative). Free vibrations are often caused by a single force impulse (e.g. a mass changing direction) and are usually damped out; they are seldom a problem. Forced vibrations are caused by periodically changing forces. These changing forces can originate from external vibration sources, from shortcomings in the tooling, e.g. mechanical imbalance, or from the machining process. They typically become significant only when they excite a system resonance frequency.

Self-excitation, a common cause of chatter¹, occurs when vibrations due to fluctuations in the machining process vibrate in one of the natural frequencies of the total machining system. This kind of vibration is usually detrimental, because of the large amplitude that is usually involved. The chip forming process and the system of cutter, machine and workpiece respond to fluctuations (variation in chip thickness and with that variation in cutting forces) in such a way that the fluctuations remain. Variation in cutting forces are for example caused by the nature of shearing during chip-forming,

¹In literature, the term chatter is often used as a synonym for regenerative chatter. Regenerative vibrations are however not the only possible cause of chatter. Chatter in this thesis refers to the more general notion of excessive noise due to vibration between tool and workpiece.

i.e. the segment-wise way the chips are formed. In milling, chip thickness varies by definition. In addition, the constant re-engagement of cutting teeth is a common cause for chatter in milling. [Kals et al. 1994]

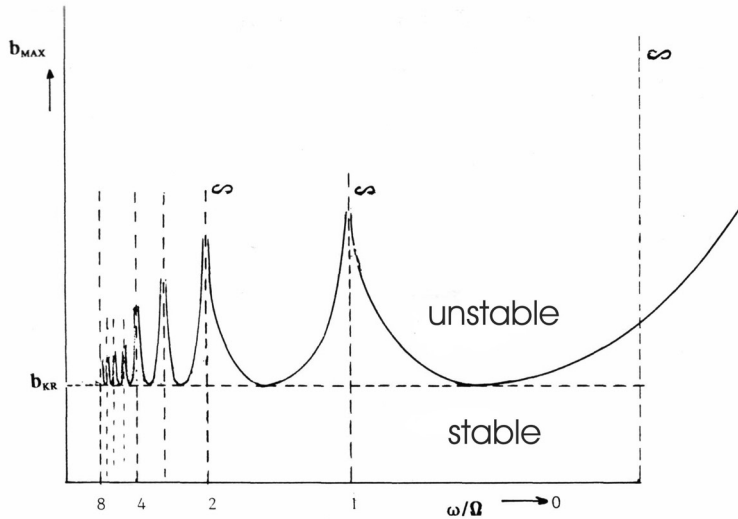

Figure 2.1: An example stability chart for turning, after [Kals et al. 1994].

For regenerative vibrations, the amplitude is primarily determined by the depth of cut. Therefore, in practice, often stability charts are used, of which figure 2.1 shows a simple example. For a given workpiece material, machine tool, cutting tool and feed, the maximum depth of cut is plotted against the ratio natural frequency / spindle frequency (or tooth hitting frequency for milling). Above the maximum depth of cut, unstable behaviour occurs with high vibration amplitudes. The figure shows that this maximum varies with the frequency ratio, but also that there is a critical ('bottom maximum') depth of cut, below which machining is always stable.

High-speed machining process dynamics

In [Tlustý 1986], Tlustý discusses the dynamics of the high-speed milling process. He states that chatter is often caused by 'regeneration of waviness'. A similar discussion can be found in [Kals 1991], which handles traditional milling dynamics. Relative vibration between the tool and the workpiece produces waviness of the machined surface. This waviness gives rise to relative vibration of the next pass on the surface, because it causes variation in chip thickness and thus variation in cutting forces. The critical chip thickness is influenced by the spindle speed (n) and the natural frequency (f) of the system. Namely, f/np , with p the number of teeth of the cutter, equals the number of waves per tooth spacing (similar to turning). If the number of waves is not a whole number, this implies variation in chip thickness and thus in forces.

This also explains why stability lobes can be utilised by varying spindle speeds. Stability lobes are reached when (a multiple of) the full tooth frequency approaches the natural frequency of the most flexible mode of the system [Tlusty et al. 1996]. Zelinski gives a straightforward explanation of the phenomenon: "At that particular speed, the rate of cutting edge impacts synchronizes with a natural frequency of the system. Although the tool is still vibrating, the cutting load is no longer fluctuating." [Zelinski 2005]. The limit for the depth of cut is then increased several times beyond the critical depth of cut [Tlusty 1993]. In fact, stability lobes are the peaks shown in figure 2.1. The higher depths of cut that can be used in those cases will result in increased material removal.

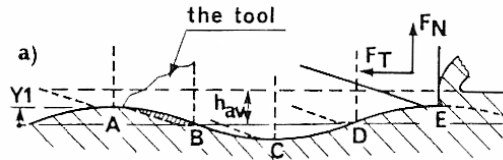

Figure 2.2: The origin of process damping, after [Tlusty 1986].

[Tlusty 1986] also discusses the role of damping. Process damping is caused by the clearance between the tool flank and the machined surface; see figure 2.2. The waviness of the machined surface results in diminishment of this clearance when a tooth moves 'down a wave'; the tool flank is then 'pushing' against the workpiece material. The variation in clearance results in an additional force, which is in phase with the velocity of the vibration as it 'follows the waves', representing the damping force. Increasing wavelength implies a smaller slope of the wave, and thus less variation in clearance, in other words less damping. The wavelength is proportional to the cutting speed:

$$w = \frac{v}{f}, \quad (2.1)$$

where w is the wavelength, v is the cutting speed and f is the frequency of vibration. Thus, process damping decreases with increasing cutting speed, reducing the role of process damping in high-speed milling. So, Tlusty concludes, in high-speed milling, the process damping, which stabilises cutting at conventional speeds, is absent or at least negligible. This is also noted in [Tlusty 1993] and [Weck et al. 1994].

In e.g. [Elbestawi & Sagherian 1991], it is noted that cutting forces also depend on cutter and workpiece deflections. This is a feedback effect which affects the chip load and cut geometry, which in turn influences cutting forces.

Dynamics of machining thin-walled workpieces

Various research has been performed on machining of thin-walled products. However, not all this research involved high-speed machining as well. Nevertheless, similar problems can occur for both traditional and high-speed machining.

A relevant notion is that at a certain point in machining a thin rib, the rib becomes more flexible than the tool [Tlustý et al. 1996].

[Chang et al. 1994] discusses experiments and numerical analyses on chatter of thin-walled cylindrical workpieces in traditional turning, with some interesting conclusions. First, chatter always occurred in one of the natural modes of the workpiece. It was also highly dependent on the dimension ratios. Second, when during the cutting process the stiffness coefficient of the workpiece became smaller, the chatter frequency gradually decreased. Third, as the dynamic stiffness changed during turning of a thin-walled workpiece, the chatter vibration mode could jump from a lower modal frequency to a higher one.

Agba et al. performed some tests on high-speed milling of a thin rib [Agba et al. 1999]. Chatter occurred during finishing passes of the rib, when the cutting frequency was near the first natural frequency of the rib (cutting speed reduction did not help). Similar results were noted in [Smith & Dvorak 1998], also based on cutting tests. Different simulation-based results are reported in [Elbestawi & Sagherian 1991]. Their developed simulation system seemed to show better surface quality and more stable cutting when the tooth passing frequency was near the first natural frequency of the workpiece. The authors compare this phenomenon with the stability lobes phenomenon described earlier. Even if these simulation results reflect reality, this phenomenon seems not practically usable, as the natural frequencies of thin workpieces will change during machining due to reduction in mass and stiffness.

Concluding, when workpieces become thin, the thin geometry becomes the weakest element when it comes to vibrations. This is reflected by the notion that chatter is more likely to occur when machining near natural frequencies of (a portion of) the workpiece.

Modelling of dynamics and deflection

When it comes to modelling of dynamics and/or deflection for thin-walled workpieces, a model should not only incorporate machining process behaviour, through a cutting force model, and tool behaviour, but also workpiece behaviour. This is confirmed in e.g. [Kline et al. 1982] and [Elbestawi & Sagherian 1991].

[Kline et al. 1982] considers workpiece deflection in the prediction of surface errors, by considering the workpiece being pushed away by the milling force. Deflection is considered statically. The variation in cutting force due to cutting geometry is considered. [Sutherland & DeVor 1986] also considers deflection statically, but considers what Elbestawi et al. call a regenerative cutting force model; one that also considers the variation in chip thickness due to cutter and workpiece deflection [Elbestawi & Sagherian 1991]. [Elbestawi & Sagherian 1991] and [Altintas et al. 1992] consider workpiece deflection dynamically, i.e. based on the natural modes of the workpiece geometry. They try to incorporate the workpiece's dynamic response in the surface error prediction, so that both static and dynamic deflections are considered. Workpiece behaviour is generally modelled through finite element analysis; the articles typically consider cantilever plate behaviour for the workpiece. Ideally, the workpiece geometry and behaviour is updated

during the calculations [Kline et al. 1982] [Elbestawi & Sagherian 1991].

In order for applicability for process planning, the reverse of the above is in fact desired: a system capable of determining correct cutting parameters for a given surface quality (and given tool and workpiece properties). Such a model for run-time calculation however seems to be far from a reality.

Another relevant field is the field of chatter avoidance. One offline chatter suppression technique is chatter prediction through models for dynamics analysis of milling, that apply time domain simulation. [Tlusty et al. 1990], [Smith et al. 1991] and [Weck et al. 1994] discuss the use of such models. These models employ transfer functions in more than one direction to take into account the dynamic behaviour of the machine. Simulation results are stored in databases in terms of permissible depths of cut, differentiated with respect to the cutting direction, radial immersion and whether up or down milling is involved. This data is used for analysing and correcting (optimising) pocketing tool paths. As thin-walled products are not an issue in these articles, workpiece behaviour is not considered; neither dynamic behaviour, nor the feedback effect of workpiece deflection on cutting forces due to the resulting chip load variation.

2.2 Machining practices

This section discusses approached and guidelines tried and tested in practice, from the area of high-speed milling as well as the machining of thin walls.

2.2.1 High-speed milling

Machining practices can be based on experience, but can also have a scientific basis. Several high-speed machining practices, varying from guidelines to detailed tool path strategies, are discussed below.

Stability lobes

Tlusty and Smith have performed a lot of research on so-called stability lobes in machining. Stability lobes were already shortly addressed in section 2.1.3; they are reached when (a multiple of) the full tooth frequency approaches the natural frequency of the most flexible mode [Tlusty et al. 1996]:

$$f = anm, \quad (2.2)$$

where f is the natural frequency of the most flexible mode, a is an integer greater than zero, n is the spindle speed in revolutions per second and m is number of teeth on the tool. The limit for the depth of cut is then increased several times beyond the critical depth of cut [Tlusty 1993]. Apparently, cutting forces are also lower in

these lobes [Tlusty et al. 1996]. A lot of research has been done on taking advantage of this phenomenon by varying axial or radial depths of cut, varying spindle speeds [Tlusty & Zaton 1983], and even adjusting the machine-tool-workpiece system by varying tool length [Tlusty et al. 1996]. Tlusty highly promotes the use of these stability lobes; in [Tlusty 1986], he already notes the possible use of this phenomenon for high-speed milling, especially when long end mills are used.

However, when thin-walled workpieces are concerned, stability lobes are hardly workable. Namely, the most flexible mode will often be that of (a thin portion of) the workpiece. Also, the workpiece - as part of the machining system - often reduces in mass quite drastically, thereby affecting the system's resonance frequencies. As noted in [Andringa 2001b], this makes it hard to predict this resonance data in advance, which is needed in order to use it as machining environment. In addition, using a resonance-based optimisation approach in an application area known for its vibration issues is risky.

Guidelines

Various sources, especially on the Internet, provides guidelines for high-speed milling. These are, however, not always adequate for machining of thin-walled workpieces as well. In general, it is advised to use fewer tools, to minimise the number of tool changes and to use smaller tools [Hurk 1998]. Furthermore, vertical set-ups are recommended for good chip disposal [Schulz & Moriwaki 1992]. In high-speed machining, typically light fixturing can be employed; one can use a 'frame' of blank material [Hurk 1998]. Most guidelines are nonetheless concerned with tool paths.

In [Beard 1997], the following guidelines can be found:

- Use gentle entry cuts; [Schulz & Kaufeld 1988] promotes ramping entry cuts for shaft end mills;
- Minimise the number of tool exits and re-entries;
- Use small stepovers and depths of cut;
- Avoid sharp changes in direction;
- In some cases, it can make sense to generate intricate details or corner cuts in separate operations, rather than generating all features using generalised cuts;
- Maintain constant cutting conditions wherever possible, as variation in cutter load can cause errors:
 - Maintain a consistent chip load (at a given feed rate);
 - Maintain a constant profile of cutter-to-material contact at a given feed rate;
 - Lower the feed when the tool encounters large amounts of material;
 - 'Pre-relieve' corners; avoid heavier chip load for a finishing cutter;

- The simpler the tool path, the better;
- For zigzag tool paths: connect adjacent paths with a looping motion, in order to diminish accelerations and decelerations.

Tlusty [Tlusty 1993] stresses the importance of good cornering strategies, as cornering can increase machining time due to low feed rates. For aircraft components, this can take up 38-54% of the total time.

Maintaining a constant chip load is an often mentioned guideline in literature. This is however more a concern in the area of die and mould machining. Not the result; constant chip load and constant cutting conditions result in less variation in cutting loads, i.e. a more stable process, thereby reducing the risk of errors or vibrations. It is achieving the constant chip load that is an issue in that area. As Beard describes it, in order to control chip load, the profile of the cutter engagement in the material should constantly be analysed. The speed and feed must fit the volume of material to be removed and the slope of the surface. The contact point between the tool and material varies according to the slope, as well as the effective tool radius [Beard 1997]. Variation in surface slope and cutter engagement is more common in the 3d tool paths and ball end mills often used in mould and die machining, than in the often straightforward 2d/2.5d tool paths and shaft end mills that are commonly used for thin-walled products. For thin-walled workpieces, there are other concerns that demand attention to minimise errors.

Machining strategies

The following approaches and algorithms with respect to tool paths, concerning mostly tool motions, are considered interesting for high-speed milling [MMSonline]:

- *Rest milling* and *pencil milling* can determine and cut material after a preceding operation with a larger tool. Their application lies in die/mold machining. They are of little interest for thin-walled products, as these approaches imply that possibly weakened portions of the workpiece can get re-machined.

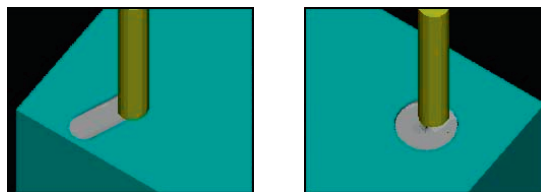

(a) *Straight-line ramp*

(b) *Spiralling in*

Figure 2.3: Ramping entries, after [MMSonline a]

- *Ramping entries* [MMSonline a]: enter gradually with a series of ramping moves, e.g. a straight-line ramp (figure 2.3(a)) or spiralling in (figure 2.3(b))

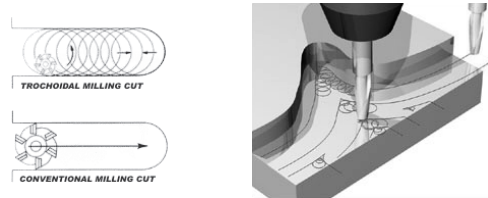

(a) *Trochoidal vs. conventional*

(b) *Trochoidal cornering*

Figure 2.4: Trochoidal milling, after [MMSonline b]

- *Trochoidal milling* [MMSonline b] is a pocket roughing operation, in which straight lines and corners are replaced by circular motions, see figure 2.4. The cutter is in contact with the material through only about 5% of its revolution, versus about 50% for normal cutting. Potential benefits are longer tool life from improved cooling of the tool, and faster material removal, because feed rate losses due to slowing through corners are eliminated.
- *Z-level machining*: instead of milling in a zigzag pattern, which causes the tool to often exit and re-enter the material, the tool path follows a spiral to machine all of a given layer in Z, before dropping to the next Z-level. It keeps a steadier load on the cutting tool by keeping the cutter continuously engaged. Aimed at die and mold machining.
- *True scallop machining* [Beard 1997] calculates the stepover distance - the distance between two adjacent tool paths - normal to the surface rather than normal to the tool vector. This will keep cuts equidistant from each other, regardless of the surface curvature, and will result in a much more consistent chip load on the cutter.
- *Feed rate optimisation* [MMSonline c] divides a given tool path into smaller segments and varies feed rate according to the material removed, see figure 2.5. Benefits are shorter cycle times, as the tool moves faster through regions where the depth of cut is light, and less strain on the tool and machine, as the optimisation aims to maintain a constant cutting load.

There is a clear bias in this collection of strategies towards die and mold machining (pencil/rest milling, Z-level machining, true scallop machining) and a maintaining a constant cutting load (Z-level machining, true scallop machining, feed rate optimisation).

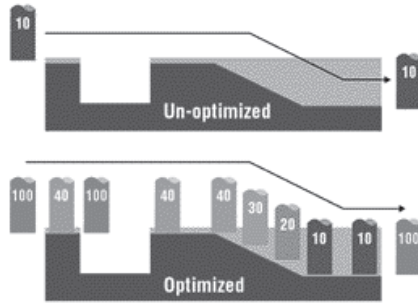

Figure 2.5: Feed rate optimisation, after [MMSonline c].

2.2.2 Thin-walled geometry

Practical approaches for the machining of thin geometry are found less in literature, but do show a trend, as this section will show.

Relieving the tool

[Tlusty et al. 1996] also gives a practical solution, which deals with the results of vibrations instead of trying to prevent them, namely by relieving the tool (see figure 2.6). This approach is applicable when the problem - a damaged rib - is in fact caused by contact between the tool and the rib above the nominal cutting zone; relieving the tool above the nominal cutting zone eliminates this harmful contact.



(a) *Contact above the nominal cutting zone.*

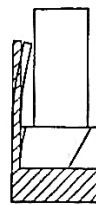

(b) *Relieved tool.*

Figure 2.6: End mill and rib, after [Tlusty et al. 1996]

Fokker Aerostructures is familiar with the phenomenon depicted by 2.6(a). It will be referred to as vibration re-machining.

Machining approaches

A common guideline for machining thin walls is to use down milling when the workpiece becomes really thin, especially when finishing, because this will generally give better results. The reason for this was already noted in section 1.2. Up milling will alternately push and pull the workpiece, thus increasing the chance of unwanted vibrations, where the resultant force in down milling will always push the workpiece [Streppel 1983].

Hanita presents an approach for milling thin webs using only down milling for finishing [Hanita]. Instead of a one-way approach in which the cutter down mills one pass, travels back in a non-cutting motion to the other end and start cutting another pass, they use a dedicated zigzag approach, as shown in figure 2.7. They apply an up milling cutting motion above the finishing pass instead of the non-cutting motion. In fact, they machine the last two depth layers together, combining down mill finishing with an efficient tool path. The final step in their approach is to make a finishing pass around the pocket to

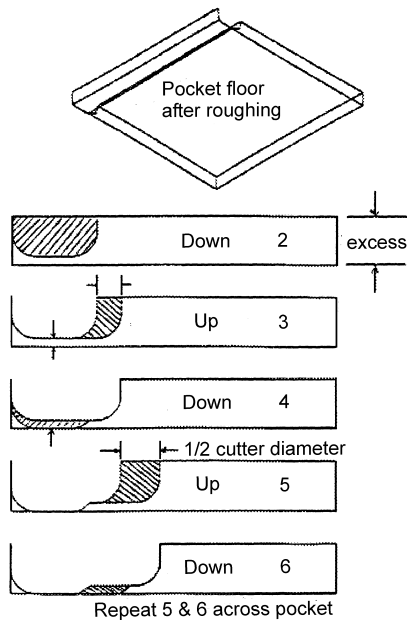

Figure 2.7: Thin web zigzag milling using down milling for finishing, after [Hanita].

remove scallops. This seems a flaw, because already thin - and thus weak - parts of the workpiece are re-machined, at risk of vibration.

Smith and Dvorak [Smith & Dvorak 1998] introduce (high-speed) milling strategies for thin web machining. The milling technique they apply is based on using the stiff, uncut portion of the workpiece to support the flexible section being cut. The significant difference for machining webs and ribs is the orientation of the most significant flexibility with respect to the orientation of the cutting tool. In their terminology, thin ribs are

created at the periphery of an end mill, whereas thin webs are thin structures created at the face of the end mill.

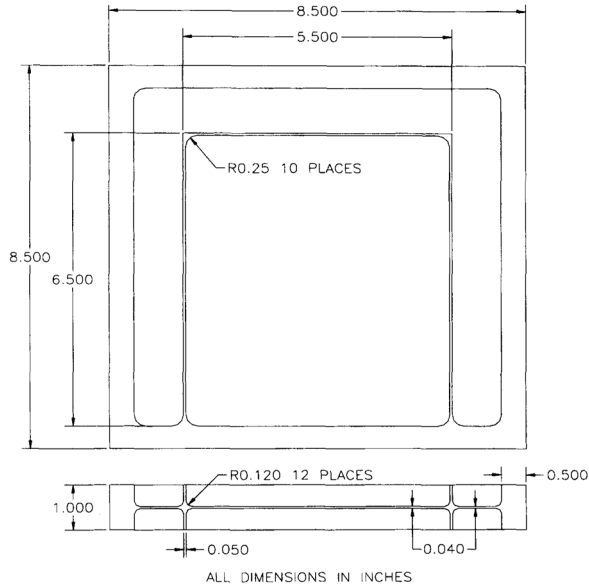

Figure 2.8: Thin-walled structure discussed in [Smith & Dvorak 1998].

Their strategy will be described on the basis of figure 2.8 and 2.9. First, everything was manufactured except for the inner pocket on one side. Then, the 'first pass' in figure 2.9(a) was slotted using the ramping motion from figure 2.9(b). The rest of the pocket was milled using the motion in figure 2.9(c), with the vertical motions in the previously milled path, i.e. in the air. In this way, scallops are removed immediately (no finishing pass needed) and the workpiece is not milled on too thin spots. Nevertheless, chatter occurred during both milling motions. In a variation of this approach, they

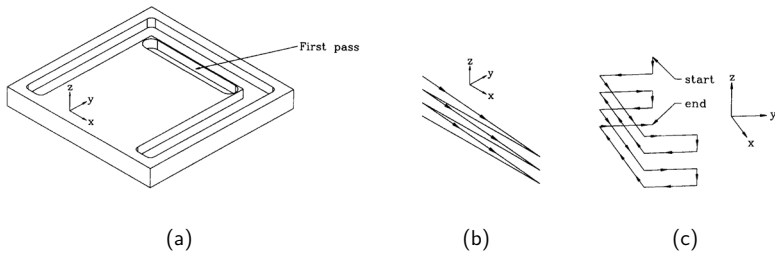

Figure 2.9: The first milling approach for the workpiece of figure 2.8, after [Smith & Dvorak 1998].

started with cutting an U-shaped slot as shown in figure 2.10, rather than a ramp-down (see figure 2.9(b)) or a plunge at the flexible end. No chatter occurred, but as the test was performed using a smaller mill, no conclusions can be drawn when comparing it to the previous approach.

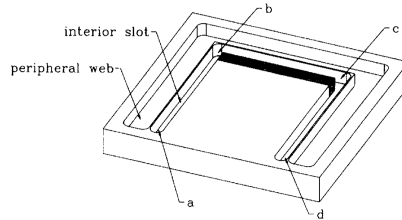

Figure 2.10: First pocketing pass for the second milling approach for the workpiece of figure 2.8, after [Smith & Dvorak 1998].

”The guiding principle ... is to choose the tool path so that the area being machined currently is supported by as much unmachined workpiece as possible. The cutting should proceed from the least supported area toward the best supported area.” [Smith & Dvorak 1998]

To demonstrate that this principle can be applied to different geometries, they tested milling the aluminium part shown in figure 2.11. It consists of one double-sided web of 1 mm thick (no ribs involved), that was milled at a cutting speed of nearly 10 m/s. After machining the first side of the test part, the second side was started with a steep ramping slot to the final web thickness. After creating a small square web with several of these ramps, the web was made progressively larger by cutting in concentric square paths. The web was machined without any chatter.

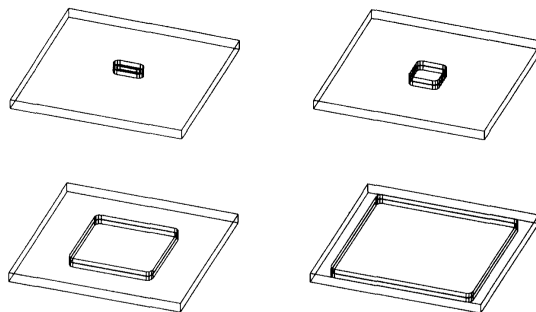

Figure 2.11: Milling a thin web without thin ribs, after [Smith & Dvorak 1998].

For thin-walled products, often the so-called step-method is applied: alternately mill each side of the wall [Hurk 1998], as shown in figure 2.12. This is in coherence with the

principle of letting the unmachined part of the workpiece support the section being cut [Smith & Dvorak 1998]. A similar approach, based on the same principle, is incremental pocketing [MMSonline d]. Pockets are machined a little at a time, so that thin walls between two pockets are supported from both sides throughout the machining cycle.

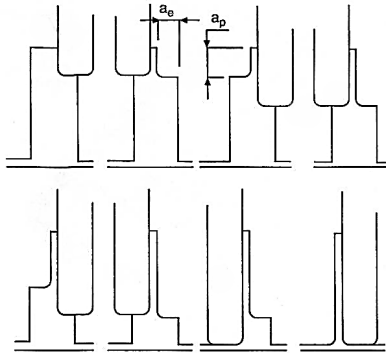

Figure 2.12: The step approach, after [Hurk 1998].

Sandvik also advises to use such machining principles, when the height-to-thickness ratio exceeds 15:1 for aluminium, see figure 2.13 [Sandvik 2003]. When that ratio exceeds 30:1, they even advise a pyramid- or tree-like approach as shown in figure 2.13(c).

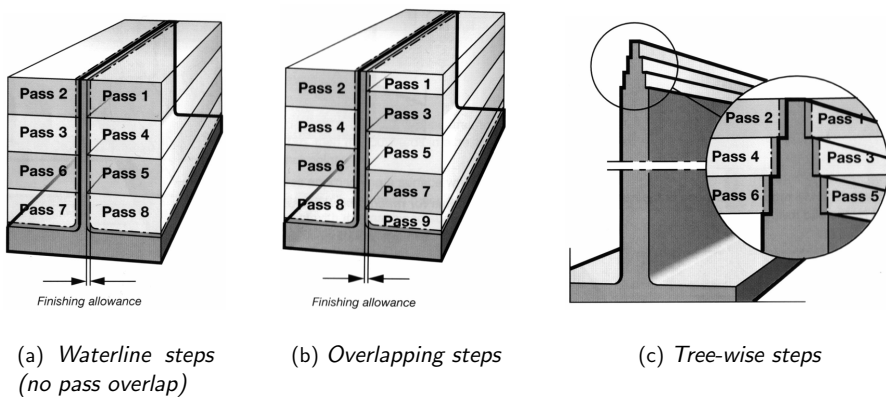

Figure 2.13: Stepwise machining principles for thin ribs, after [Sandvik 2003].

When pocketing thin walls, Sandvik advises to use ramping motions between depth steps (figure 2.14(a)). When milling webs, they advise starting in the centre and milling outwards, as figure 2.14(b) shows [Sandvik 2003]. This is clearly similar to figure 2.11 after [Smith & Dvorak 1998].

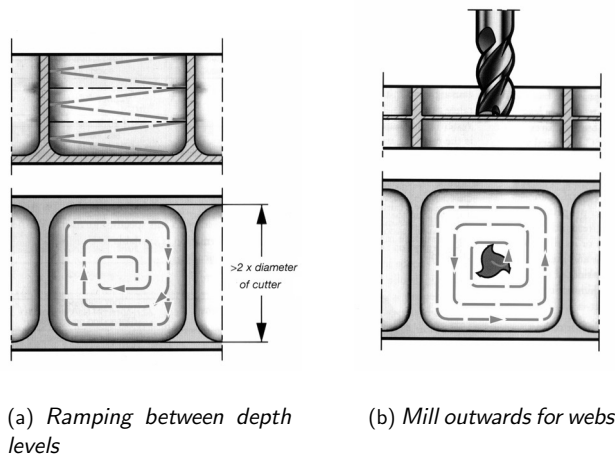

Figure 2.14: Pocketing principles, after [Sandvik 2003].

2.3 Computer-aided process planning

Process planning can be considered as the task, or set of tasks, that works out how a product design can be manufactured. The resulting output are manufacturing instructions for the men and/or machine(s) that will do the manufacturing. This thesis only considers process planning of single parts.

Computer-aided process planning software aims to aid process planners in their work and/or automate process planning tasks. Like process planning is a step between design and manufacturing, computer-aided process planning can form the link between computer-aided design and computer-aided manufacturing [Houten 1991].

2.3.1 Process planning

The main goal of process planning is to find the best way to realise that design (the set of geometrical and technological product specifications) within the constraints of the manufacturing resources [Kals et al. 1990]. These latter constraint are not only technical constraints, but can also concern logistic aspects like machine tool loading. Main process planning tasks are:

- product model interpretation,
- determination of manufacturing methods,
- selection of resources,
- determination of setups,

- detailing manufacturing methods into operations,
- determination of operation sequence information,
- generation of manufacturing instructions for man and/or machine,
- capacity planning.

Obviously, the task focus will differ for different products, manufacturing processes and/or industries. In mass production for car engines for example, production lines can get built around a process plan. Process planning for a prototype product puts very different demands on a process plan.

2.3.2 Computer support approaches

Computer support in process planning can help increasing speed of the planning tasks, consistency and efficiency in the plans, and reduce dependency on skilled process planners. Computer aided process planning can be variant-based or generative in nature [Salomons 1995]:

Variant process planning: Variant CAPP is based on the idea that similar products can be manufactured with similar process plans. The computer in this approach aids in identifying product similarities, retrieving the associated process plan (template) and editing that to create a new plan that fits the requirements of the product at hand.

Generative process planning: Generative CAPP approaches process planning automation by trying to automate process planning tasks through applying formalised manufacturing knowledge. New process plans are generally built from scratch, based on the manufacturing knowledge and data describing the manufacturing environment.

Of these two, the generative approach has appeared as the most viable one. The variant approach has several long-noted drawbacks. The quality of a variant process plan still depends on the process planner, because the software only assists him in his (manual) tasks [Alting & Zhang 1989]. The approach is impractical if small batches of widely varying parts are produced, it doesn't capture the actual process planning knowledge and it inherently has the risk of reusing out-of-date processes or even repeating mistakes [Shah et al. 1991]. A survey like [Shah et al. 1991] indicates that research has been predominantly focussing on generative process planning for quite some time.

2.3.3 Form features

Features - generic shapes or characteristics of a product with which engineers can associate knowledge useful for reasoning about the product - have proved to be useful

and important in CAD/CAM [Han 1996]. In CAPP, features are almost universal as the medium for part description [Shah et al. 1991].

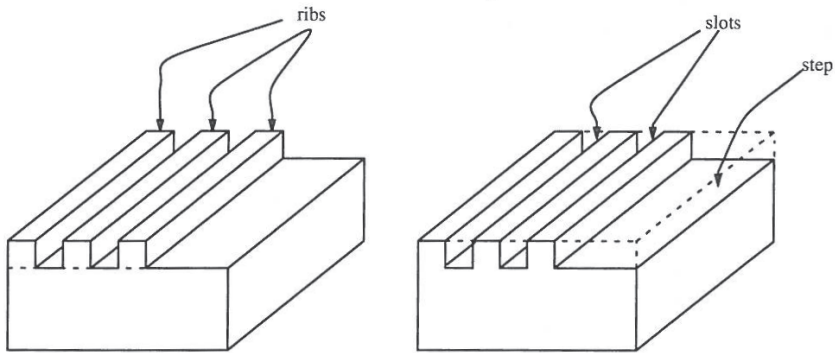

Figure 2.15: An example of multiple views, a design view and a manufacturing view, after [Salomons 1995].

Many CAD models from commercial CAD systems are feature based these days. Although these features may not always have functional engineering knowledge associated with them explicitly, designers will use them with their function in mind. These design features can differ significantly from features used in manufacturing, and designers and manufacturing engineers can view the same model in terms of different shapes, as the example in figure 2.15 shows. This is sometimes referred to as the multiple views problem [Salomons 1995].

There are generally three ways to come to a manufacturing feature model. The first is *design by manufacturing features*. This approach has two major drawbacks [Mäntylä et al. 1996]. First, forcing a designer to work with manufacturing features requires him/her to think in manufacturing terms, which can be unnatural and inconvenient. Second, the designer is forced to assume the role of a process planner. The manufacturing features he may use may not correspond to the best way to produce the part. On the other side of the spectrum is *feature recognition*, which analyses the geometric model of the part to find the relevant manufacturing features. Finally, there is *feature model conversion*: converting a feature model of the part from one domain (design) to the other (manufacturing). Unless direct mapping from a feature in one domain to the other is sufficient, which is not always the case, feature recognition techniques are needed to do the conversion [Han 1996]. This approach also bears the risk that - depending on the quality of the conversion - the designer determines the manufacturing features, in this case indirectly, which is not necessarily the optimal manufacturing feature set for the part.

Of the most common solid model representations, Constructive Solid Geometry (CSG) and Boundary Representation (Brep), Brep has emerged as the dominant representation for most major CAD/CAM systems, and with that as the input for feature recognition algorithms. Brep typically uniquely defines the entities, e.g. faces, edges and

vertices, of a solid. The three most common feature recognition approaches are graph matching, volumetric decomposition and hint-based reasoning. Graph pattern matching, the most popular approach in the feature research community [Han 1996], tries to find (match) particular patterns for features in a part. Early works in this area are [Choi et al. 1984] and [Henderson & Anderson 1984]. The volumetric decomposition approach decomposes the input into a set of intermediate volumes and then manipulates (recombines) the volumes to produce features. Hint-based reasoning starts from a minimal indispensable portion of a feature which should be present in a part, and performs extensive geometric reasoning. The latter two typically reason about features as volumes to remove. [Han et al. 2000]

2.3.4 Knowledge-based support

The power of feature models in manufacturing applications is based on associating feature types with manufacturing process models [Mäntylä et al. 1996]. Process planning concerns itself with deciding how a part should be manufactured. So generative CAPP, where the part is usually described in terms of features, concerns itself with deciding how the features should be manufactured. Shah et al. [Shah et al. 1991] distinguish between traditional and artificial intelligence (AI) based techniques. Traditional systems used deterministic logic like decision tables or decision trees, composed of conditions and actions. Because these approaches suffered from inadequacies, AI techniques became of interest. AI is typically capable of knowledge-based searches, which are required for proposing alternative solutions. AI systems, especially rule-based ones where the inference mechanism is separated from the rules on which it operates [Houten 1991], grew in significance over the years [Alting & Zhang 1989], [Shah et al. 1991], [ElMaraghy 1993].

No closed set of feature types will suffice for any application area; there will always be organisations that need feature types outside the defined set for its own purposes [Han et al. 2000]. This on one hand indicates a need for means to define feature types. On the other hand, it shows the difficulty of achieving full automation through feature based manufacturing. Even with an extensive feature set, and an associated extensive knowledge set, it is not possible to describe all situations that can occur in practice.

2.3.5 Work by the Design, Production and Management research group

The Design, Production and Management research group has many years of experience with computer-aided process planning, especially for machining. In the late seventies and the eighties, research CAPP systems were developed such as CUBIC, ROUND, XPLANE and FIXES, eventually leading to development of the most comprehensive system, PART, which was finished in the early nineties [Houten 1991]. PART, a generative CAPP system, combined powerful feature recognition with knowledge-based method and tool selection and high flexibility. This flexibility for example takes form in configuration of the workflow; sequences of tasks can be defined differently depending

on the environment of the target process plan. This means that some of those tasks are flexible with respect to reasoning with incomplete data. Other forms of flexibility are the possibilities to define and extend the method selection knowledge base to suit a customer's experience and needs, and the possibility to define recognition algorithms for customer-specific feature types.

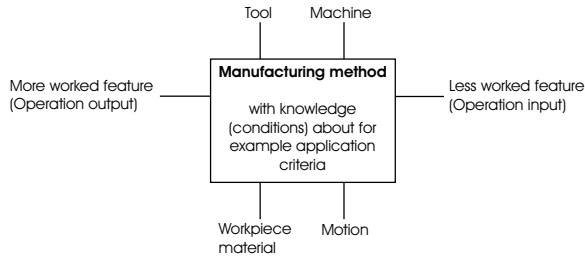

(a) *A method can decide when and how an operation can be applied to a feature.*

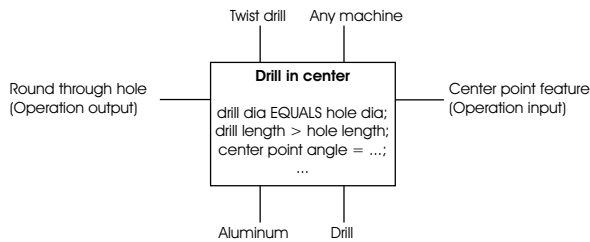

(b) *Example: a hole can be machined with a drill motion from a center point feature in an aluminium workpiece using a twist drill on any machine, if the related conditions can be satisfied.*

Figure 2.16: The manufacturing method concept

Feature recognition was chosen as interface with CAD essentially because of its generic nature; it makes the origin of the CAD data irrelevant [Houten 1991]. Operations can be determined for the features by automatic machining method and cutting tool selection. These are related, because method selection should consider the available tools, i.e. don't choose an operation for which there is no cutting tool. The knowledge used in this selection is captured in methods (rules); see figure 2.16. The actual selection works backwards, from the final part specification to the blank specification; the system's inference engine first tries to find operations to create the final situation and works back from there. At runtime, the selection applies the rules to the features, builds a search tree and evaluates the alternatives through that tree. Associated with each candidate

method are specifications for the cutting tool to use. If these specifications can't be met by any available tool, the method is rejected. Method selection will deliver a set of machining methods (operations), together with selected cutting tool types and attribute ranges. Subsequent tool selection determines the smallest set of tool assemblies that can machine all features in a given setup. For establishing cutting conditions, a mix of approaches is used. Depending on the kind of operation (tapping, drilling, milling, et cetera), the software uses tables, straightforward formulas or elaborate process models.

Specifying and maintaining the knowledge and environment data in the system are system administrator tasks. In this, feature recognition algorithms and machining methods and their conditions are special cases. Namely, both forms of knowledge are automatically converted into C/C++ source code and subsequently built into executable software by dedicated tools. [Houten 1991]

PART was later made commercially available (see also section 1.4) and has since then been noticed as being one of the few process planning systems to have achieved significant industrial use [Mäntylä et al. 1996].

2.4 Computer support for planning high-speed machining

Hardly any literature on process planning for high-speed milling was found. Research on computer support for high-speed machining, such as [Choi et al. 1997], shows a focus on the die and mould application area.

Many commercial CAM systems that can be found on the Internet, claim to be suitable for high-speed machining. This often means they provide particular tool path strategies, e.g. z-level machining. Keeping cutting conditions constant is also a largely mentioned feature. Following is an overview of commercially offered high-speed machining functionality and the CAM systems that offer them.

- Z-level machining (or contour line machining): see section 2.2.1 for a description. [DelCAM] [Terasaki 1996] [NCGraphics 1999]
- Tangential arc entries/exits: the tool moves onto and off the job in an arc motion; the tool motion thereby becoming smoother and maintaining a higher speed. [DelCAM] [Terasaki 1996] [CNC Software Inc]
- Minimise full width cuts (see figure 2.17(a)): the ordering of tool paths is optimised so that the number of full cuts are minimised, thereby allowing higher feed rates and reducing tool wear and damage. [DelCAM]
- Skimming (or automatic clearance z-value adjustment, see figure 2.17(b)): when moving to another operation, the tool retracts as little as possible, thereby reducing travel distance between machining operations, rather than retracting above the workpiece each time. [DelCAM] [Terasaki 1996] [NCGraphics 1999]

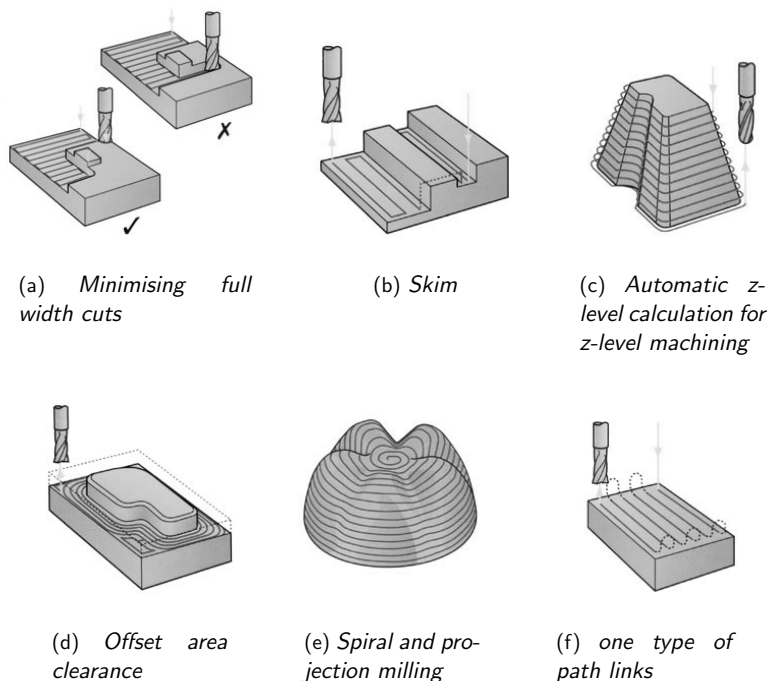

Figure 2.17: PowerMILL methods, after [DelCAM].

- Automatic z-level calculation for z-level machining (see figure 2.17(c)); in z-level machining, the workpiece is 'sliced' into levels. Instead of using a constant step down, the number of levels can be automatically rearranged, so that the same amount of material is removed at each level, resulting in more consistent tool loading. [DelCAM]
- Cusp height control: when the pitch is greater than specified, additional tool paths are generated to compensate for too great distances between adjacent tool paths. This minimises cusp height of the cutting marks. [Terasaki 1996]
- Dedicated pass leads and links (see figure 2.17(f)): several CAM systems offer several options to control how the tool behaves at the beginning and end of individual tool paths, and how tool path segments are joined together. This prevents dwell marks and results in a more even tool loading as well as increasing surface cutting speed. [DelCAM] [CNC Software Inc] [NCGraphics 1999]
- Rest milling and pencil milling (finishing); see section 2.2.1 for a description. [Terasaki 1996] [NCGraphics 1999] [OpenMind 1999]
- Feed rate control/optimisation; see section 2.2.1 for a description. [Terasaki 1996] [CNC Software Inc]

- 3d equidistant machining (or constant surface stepover machining or true scallop machining); see section 2.2.1 for a description. [NCGraphics 1999] [OpenMind 1999]
- Offset area clearance (see figure 2.17(d)): this tool motion strategy clears an area with contours generated by offsetting the initial slice until no further offset is possible, resulting in more efficient milling. The generated tool paths will contain fewer sudden changes in velocity than traditional machining strategies. [DelCAM]
- Spiral and projection milling (see figure 2.17(e)): the tool path is created by projecting a circular, spiral or radial machining pattern towards or away from an imaginary point in the model, resulting in a rather smooth and continuous tool path. [DelCAM]
- Support of spline machining: machining using NURBS-based NC code. [DelCAM]

	PowerMILL [DelCAM]	CAM-TOOL [Terasaki 1996]	MasterCAM [CNC Software Inc]	Machining Strategist [NCGraphics 1999]	HyperMILL [OpenMind 1999]
Z-level machining	X	X		X	
Tangential arc entries/exits	X		X		
Minimise full width cuts	X				
Skimming	X	X		X	
Z-level machining level calculation	X				
Cusp height control	X	X			
Path segment links/cornering	X		X	X	
Pencil and/or rest milling		X		X	X
Feed rate control		X	X		
3d equidistant machining				X	X
Offset profiling	X				
Spiral/projection milling	X				
Spline machining support	X				

Table 2.1: HSM-related capabilities of several CAM software.

Table 2.1 shows an overview of several commercial CAM systems and the HSM-related capabilities that they state they offer. Of the considered systems, PowerMILL by DelCAM seems to supply the most extensive and coherent set of high-speed machining functionality. Another thing that table 2.1 shows is a focus towards high-speed machining for die/mold machining (Z-level machining, pencil/rest milling, 3d equidistant machining,

maintaining constant cutting load). There can be different explanations for the little attention paid to high-speed machining for thin-walled parts. Perhaps the market is considered too small to be commercially attractive, or there is too little agreement in the industry on what are the good approaches for thin products, or such solutions are considered too difficult to be implemented in CAM systems. Either way, it is a fact that computer support in this application area is behind.

Chapter 3

Process planning thin-walled parts for high-speed milling

In manufacturing, quality is the concept of making products fit for a purpose and with the fewest defects. The quality that is weighed heaviest in process planning for thin-walled parts like structural aircraft components is the quality of the shape and surface: the accuracy of the product with respect to the design. This is the quality that the manufacturing process being process planned will be responsible for. The product must comply with the accuracy limitations of the design. These are set in terms of surface roughness and tolerances.

3.1 Accuracy

Process planning should deal with the influences that the manufacturing process has upon the accuracy. Manufacturing should be planned in such a way that the total of the influences stays within the specified accuracy range. To do this as well as possible, the factors that influence accuracy should be known during process planning.

3.1.1 Accuracy in milling

In machining, the main influences on accuracy are

- vibrations
- bending of the tool or the workpiece
- stresses, especially where thin parts are concerned

Of course, flaws in tooling like machines, clamps and cutters can cause accuracy limits to be exceeded. These are left outside the scope of this thesis.

Internal stresses

Stresses occur in the workpiece material. The stringent quality control in the aircraft industry tries to minimise such internal stresses. Nevertheless, most often there is some extent of residual stresses in the blank material. The material with this stress is (partially) removed during machining. Machining itself introduces stresses in machined surfaces. These can mostly be attributed to plastic deformation (work hardening) and stresses due to local temperature variation (thermal stresses). Such stresses can influence the product's characteristics like fatigue strength. Another consequence, which is more measurable, is that stresses can cause a part to distort [Juneja & Sekhon 1987]. Such distortion, which especially affects thin-walled parts, can result in exceeded shape or dimension tolerances.

Bending

Bending can especially influence shape and size tolerances. Both the tool and the workpiece can bend due to cutting forces. The magnitude of the cutting forces depends especially on the process variables. The deflection due to these cutting forces is limited by the resistance to bending, which depends on shape, size and material of the bending item, be it the tool or the workpiece, or both.

Vibrations

As described in section 2.1.3, machining vibration can be free, forced, or self-excited. Free vibrations usually hardly affect accuracy. Forced vibrations can be caused by external vibrations, driving machine elements or by the machining process itself. External vibrations or those caused by driving machine elements should be addressed through the machine-tool system, if they jeopardize accuracy. Most troublesome is chatter due to self-excited vibrations: forced vibrations caused by the machining process that amplify themselves up to intolerable excess. Vibration occurs constantly, because the cutting force varies constantly. The cutting force will vary by definition because [Boogert 1994]:

- the thickness of cut continuously changes during the engagement of a tooth, and
- the teeth of the cutting tool are cutting intermittently and the number of teeth in cut is not always the same.

Cutting forces also vary during turning, in which the above two issues are not the case. They vary to a lesser extent however; turning is a more stable process in this respect. The varying cutting force causes chip thickness to vary, which in turn affects the cutting force again. Also other aspects of the chip forming process can cause fluctuations. When these effects amplify each other up to instability, chatter can occur.

The dynamics of machining involve the dynamics of the cutting process itself, and the dynamics of the machine-tool system, built up of the machine tool, the cutting tool, the workpiece and possibly other elements like fixturing tools.

3.1.2 Implications for high-speed milling of thin-walled parts

It is essential to establish that thin-walled products are the weaker elements in all the important phenomena that affect milling accuracy:

- they are more prone to distortion due to residual stresses,
- they bend more easily,
- they vibrate more easily.

The next subsections will go deeper into how these influences for high-speed milling of thin-walled products differ from traditional milling.

Residual stresses

Thin-walled products will be more prone to distortion due to residual stresses. According to Marusich & Askari, the machining-affected layer - in which the residual stresses occur - is on the order of 1 mm for Al7050; on the same length scale as the wall thickness of aerospace structures can be [Marusich & Askari 2001]. Marusich & Askari did not use high-speed machining, in which the cutting forces will generally be lower than when using a traditional milling process. Regardless, these stresses pose a problem in practice.

Bending

For conventional products, the cutter will usually be bending far more than the workpiece. When machining thin walls, the workpiece geometry may be the weaker of the two, or both workpiece and cutter may bend. This is all very dependent upon the momentary state of the workpiece being machined.

Vibrations

The resulting products (and thus intermediate workpiece forms) are more flexible than traditional milled products. This makes them bend more easily, and it makes them also vibrate more easily. Especially during finishing passes - when a workpiece portion is already thin - there is a risk of excessive vibrations.

When machining thin walls, vibration damage does not necessarily occur at the point where the cutting force is acting. It often occurs *above* the cutting zone, where

vibrating workpiece material hits the tool flutes; see figure 2.6(a). This is called *vibration re-machining*. The damaging vibrations are not necessarily regenerative vibrations.

High-speed machining is more sensitive to vibrations than traditional machining processes. The tool and spindle rotate at such high speeds that any unbalance in these areas will more easily result in vibrations. In addition, process damping is practically absent for HSM cutting speeds.

The role of the workpiece in the dynamics also changes. First of all, in the total system passing on the vibrations, the workpiece is a weak link when it becomes flexible. So, when the system hits a natural mode, it may well be (portions of) the workpiece that deflects the most. It is not flexible from the start however; machining usually starts with a massive block. During the machining, both mass and stiffness of the workpiece decrease drastically, and not evenly distributed along the workpiece. This means that the natural frequencies and natural modes of the workpiece will constantly change during machining. In milling of customary machining products, the workpiece is usually ignored as a changing factor in order to simplify stability calculation. This is no longer justifiable for these kinds of products.

3.1.3 Predictability

To find out in detail what the influences of the manufacturing process are upon accuracy, one can attempt to predict the occurring phenomena and how they affect a workpiece. This can yield valuable information for the process planning of a part.

Residual stresses

Residual stresses can come from plastic deformation and/or thermal effects of

- the process that created the blank workpiece, which is often forming
- the machining process

In order to predict residual stresses in the workpiece and the resulting deflections, both need to be taken into account. In case a product is heavily asymmetrical, the influences of the initial residual stresses in the blank will be most notable. Having a thin-walled portion of product geometry near the original blank's surface will mean that that portion will contain what's left of the initial stresses. If there is no material with counterbalancing stresses, the product will warp. Predictability and controllability of this effect is improved if blanks are delivered with constant quality. This thus depends on the blank material supplier. It has appeared that machining a (symmetrical) product asymmetrically can have the same effect as described above. First machining one side of a large wall with standard conditions and then machining the other side with more careful, thin-wall conditions can result in a similar distortion. Using different cutting conditions results in different residual stresses on each side that are not in equilibrium. The resulting

bending moment is too large for the remaining material to resist. Any accurate prediction of the residual stresses due to machining operations that takes the total of thermo-mechanical effects and process parameters requires reverting to finite element analysis (FEA). Marusich & Askari did so for Al7050 and could find no intuitive correlation of stresses to machining parameters such as speed or chip load [Marusich & Askari 2001]. If the stresses and their distribution were known, calculating the resulting workpiece deflection would require FEA as well, apart perhaps from simple or simplified cases.

Bending

Bending due to cutting forces - when considered statically - is relatively straightforward to do calculations on. The shape of the workpiece (product) however is usually not straightforward. Accurate deflection calculations usually demands FEA calculations. In addition, the workpiece shape changes during the machining process, and so will the second moments of inertia; the resistance of the workpiece (shape) to the cutting forces. When considering that, FEA appears a too heavy tool for the job. Useful predictions can also be made by analytical calculations. The sacrifice is that one can only predict deflection of simple portions of the workpiece or a simplified model of (portions of) the workpiece; simplified to cantilever plate or cantilever beam problems.

The fact that a wall is rather a plate than a beam has implications for how the wall will really deflect due to the (local) cutting force. As discussed in [Ouwkerk 2003], the cutting forces only have a deflecting effect over a portion of the wall. The deflection decreases when moving away from the point where the force is acting. This was suggested by literature [Timoshenko et al. 1959] and confirmed by calculations. As increasing length makes a wall stiffer in analytic calculations, the calculations should work with an effective length [Ouwkerk 2003]. Simplification to a cantilever beam problem is may give practical - usable - predictions, but the validity of the calculations must be guarded.

Vibrations

Chatter is extremely difficult to predict. As noted in the previous section, natural frequencies of (portions of) the workpiece become the vulnerable ones, but these frequencies change as the workpiece is being machined. The commonly used approaches would require determination of the dynamic response of the workpiece. This also demands finite element analysis. Due to the changing workpiece, its dynamic response would need constant recalculation. Unless such a calculation is drastically simplified, this seems practically unusable (and such a simplification must be justifiable).

3.1.4 Prevention

Process planning can be defined as the systematic determination of the manufacturing operations by which a product must be manufactured economically and competitively. The primary goal of process planning is the definition of feasible manufacturing operations

needed to manufacture a product [Boogert 1994]. In other words, the primary goal of process planning is to create a manufacturing plan that results in an accurate product. Any negative influences upon accuracy must be minimised; problems that can affect accuracy should be avoided. In order to prevent or minimise potentially problematic issues, it can be useful to be able to predict phenomena and the extent of their influence upon accuracy. This is a reliable approach, but not necessary. Extensive FEA calculations may help create a good process plan, but at the cost of time and effort consumed by these calculations. Prevention does not necessarily require prediction.

The next subsections deal with how influences can be minimised that affect the accuracy of thin-walled parts produced using high-speed machining. Most of these minimisations can be considered as part of process planning, some to a greater extent than others.

Residual stresses

Residual stresses will always be present to a certain extent in machined products; it is a normal phenomenon. Thin products are however exceptionally sensitive to them. The stresses themselves as well as the distortions that they result in are hard to predict. Due to this hard predictability, process planning must try to minimise the effects of these stresses. This can be achieved by either minimising the stresses themselves or by balancing the stresses for a thin wall. This last option implies that both sides of a wall should be machined under the same conditions as much as possible. (Note that this is hard to achieve when a horizontal setup is used.)

Of course, relatively predictable aspects can be taken into consideration in process planning. Fokker Aerostructures for example buys its blanks from a supplier with a very constant product quality. Blanks with comparable sizes will thus have comparable residual stresses from the forming process.

When one presumes a certain extent of predictability, there is another option to come to an accurate product: compensate for the deflection. In other words, process plan a warped product, and when machined, the final product will 'distort' into the (unwarped, straight) product that is actually desired. Drawback of this approach is that it assumes the residual stresses, the distortion and the influence of the machining process to be predictable and controllable. This makes practical feasibility of this approach highly unlikely.

Bending

Problems that can occur due to bending are plastic deformation due to excessive bending and inaccuracies due to temporary elastic deflections.

Plastic deformation of workpiece or tool is rather easy to prevent. One needs to prevent that bending stress exceeds the yield point. With a given material type and a given second moment of inertia, a maximum force can be determined that may not be

exceeded. On the other hand, if deflections due to elastic deformation are restricted to a sufficiently small limit, it can be assumed that bending stresses are too low to cause plastic deformation.

If either tool or workpiece deflect elastically, this means that they are pushed away from each other. In other words, either tool geometry, workpiece geometry or both are not in the place where they are assumed to be. As the material gives in to the bending forces, it is to be expected that the resulting workpiece geometry tends to be larger (thicker) than specified. Tool deflection can be taken into account through a cutting force model, as done by Boogert [Boogert 1994]. He however ignores workpiece deflection.

To prevent - or rather minimise - inaccuracies due to workpiece bending, there is an approach which is in essence quite straightforward: use the workpiece to resist bending as much as possible. To keep a thin workpiece portion from being pushed away by the tool, it must be locally supported by other workpiece material. Such thicker workpiece material will have a higher second moment of inertia. If the machining approach

- leaves sufficient material on the workpiece to support the thin portion
- ensures that when the cutter machines thin geometry, it always does so near thick geometry

then the cutting force - or rather bending moment - is largely taken up by the supporting, stiffer workpiece geometry. In short, workpiece bending can be minimised by providing workpiece stiffness where and when thin geometry is being machined. Approaches described in section 2.2.2 are based on this notion.

Bending can however not be viewed entirely independent from vibrations. The forces that cause the bending are not constant in magnitude and direction.

Vibrations

The difficulty of predicting excitation vibrations for thin-walled products make that prevention in the sense of avoiding dangerous natural frequencies is hardly possible.

The other vibration risk, vibration re-machining, can be addressed with the same approach as bending. The wagging (swaying) of the thin workpiece bit that causes vibration re-machining always involves some bending of this workpiece. Providing local stiffness at the point of machining will reduce the deflection of the bending vibration and with that the possible damage due to this effect.

This 'clamping' approach can also help reduce the damage due to excitation, again because the workpiece is less flexible at the point of machining and thus can vibrate less violently. Also, if this clamping is substantial enough, it may be better justifiable to use simplifications during chatter predictions. If part of the workpiece is substantially thinner than the other, it seems more reasonable to consider just natural modes of that thin portion (which can have a simpler shape).

Apart from offline chatter suppression techniques, it is also possible to use online techniques: try to detect chatter through sensors and vary process parameters to get rid of it.

3.1.5 Consequences for process planning

In existing process planning systems, hardly any of these problems are usually addressed. This can have to do with the fact that the problem's influence on accuracy is small for the kind of product and the kind of milling considered. For example, residual stresses in machined workpieces often do not affect accuracy very much because parts are not thin and thus have enough resistance against warping.

In traditional process planning, and in research as well, these accuracy issues are usually taken on through cutting conditions. A lot of knowledge and investigation on the subjects is focussed on models and collected data of the influence of adjustable process parameters on these issues. This is partially explainable by the large base of knowledge and data that has been gained over the years, which can be exploited. Besides, in traditional milling, the machining process is the most changeable and controllable factor that can affect accuracy. The choice of tooling is often based on their capabilities, and are therefore often a fixed factor in the accuracy issues mentioned here. Machining process parameters are easily adaptable, when compared to the workpiece or tooling, and thus provide the promptest way to move machining into or out of a situation resulting in inaccuracy like chatter. In other words, the machining process itself is the most volatile factor in traditional machining.

When high-speed milling thin-walled products, the machining process is still a volatile factor. However, as the previous sections discuss, the workpiece is likely to be a more volatile factor when it becomes thin-walled. As the thin-walled nature of the workpiece is the largest cause for concern for the product's accuracy, it must receive the most attention during process planning.

This concern is reflected by the way that the threat of potential accuracy problems can be minimised, as described in section 3.1.4. Most of the mentioned measures are strongly related to the workpiece stiffness. An automated process planning software system ideally incorporates a lot of these measures. In other words, a subset of them can be regarded as demands and wishes for such CAPP software.

3.2 Reviewing the task division in process planning for thin-walled parts

It has been mentioned that different influences play a role for accuracy, when high-speed machining of thin-walled products is compared with traditional machining. Process planning must focus on the most critical factors; consequently, this focus will shift.

Existing process planning tasks are not necessarily suitable for these issues. Therefore, a review of generative process planning, both main tasks and task division, follows here.

3.2.1 Traditional generative process planning

The word 'traditional' is used here to refer to generative process planning for common - non-thin - products with common - non-HSM - machining techniques.

Process and operations planning for machining comprises [Houten 1991]:

- the interpretation of the product model
- the selection of machine tools and tool sets
- the determination of set-ups
- the design of fixtures
- the determination of machining methods
- the selection of cutting tools
- the determination of machining sequences
- the calculation of tool paths and cutting conditions
- the generation of NC programs
- capacity planning

The following subtasks are left out of scope for this thesis:

- the selection of machine tools and tool sets: due to the high-end nature of high-speed machining technology at this moment in time, the selection of tooling is largely known on beforehand
- the determination of set-ups and the design of fixtures: in practice, it appears that these tasks are hard to automate in general to generate a satisfactory end result for a process planner
- the generation of NC programs: this is post-processing (translation) of the technical end result
- capacity planning: the focus of process planning in this thesis does not exceed the level of a single machine

This leaves the following tasks:

- the interpretation of the product model: determine the functional faces to create [Geelink 1996] and the volumes to remove

- the determination of machining methods: determine the approaches (methods) to use to remove the volumes and create the functional faces
- the selection of cutting tools: determine the cutters to use for the chosen operation methods
- the determination of machining sequences: determine the sequence in which to machine the determined operations
- the calculation of tool paths and cutting conditions: work out the operations (methods) for the cases to which they are applied; apply the approaches (path strategies and conditions) to the specific geometry to machine

3.2.2 General approaches to process planning issues for thin parts

The core accuracy issues all involve deflections. There are a number of ways to approach these problems:

- prevent or minimize the deflection's cause,
- minimize the resulting deflection,
- minimize the deflection's effects on accuracy by compensating for it.

For all cases, prevention or minimization can typically be achieved through cutting conditions:

- work hardening and thermal stresses are related to cutting conditions,
- a bending cutting force's magnitude depends on how the machining process is carried out and is very much influenced by the cutting conditions
- chatter is clearly related to the dynamics of the machining process; vibrations can often be 'tuned away' by changing the cutting conditions

So in theory, determination of cutting conditions can be a powerful tool in prevention of accuracy problems. However, this requires predictability of the phenomena and of the phenomena's result on the thin workpiece. This also holds for compensation-based approaches. Moreover, to be usable for process planning software, predictability is required in such a form that it is usable to determine cutting conditions based upon accuracy. As noted in section 3.1.3, not all phenomena are predictable, especially not in a form suitable for process planning software.

Minimization of the resulting deflection is thus not just an option. It becomes a necessity because the other options are too difficult to be feasible. Instead of reducing deflection by reducing its source, the resistance against deflection of the deflecting element can be increased to achieve the same result. For thin-walled geometry, this implies

providing support. The key in dealing with the weak, volatile portions of geometry is essentially keeping the workpiece as stiff as possible as long as possible. Moreover, support of the workpiece portion being machined is vital. This is reflected in machining approaches commonly used for thin walls, often referred to as 'waterline' or 'step-wise' machining. Such approaches are noted in literature, see section 2.2.2. These approaches alternately machine the different sides of a thin wall.

So, machining strategies appear as key element for providing stiffness support to thin-walled workpieces, therefore for achieving accuracy and thus for process planning. However, the scope of the strategies needs to be considered as well. Separate sections are devoted to this later in this chapter.

3.2.3 The role of strategies and their scope

Approaches like 'waterline' or 'step-wise' machining show two essential aspects involved in handling the machining of thin-walled products:

- the sequence in which volumes of material are removed is a key factor in dealing with low workpiece stiffness during machining
- the product must be viewed in terms of volatile geometric elements; the volumes to be removed should reflect the way to manufacture these volatile elements correctly

Especially the latter aspect is important. Normally, machining process planners, and also process planning software, will view and analyze a product in terms of volumes to remove. For thin-walled products, process planning must be based on the weak (or weakening) product geometry that results and base the volumes to remove on good manufacturing approaches for that product geometry.

Traditional process planning tends to deal with technological issues on a local level; most technological aspects are dealt with through tool paths and cutting conditions. Issues that are dealt with on a more global level, often are more related to economical aspects by nature. Examples are time or cost optimisation of operation sequence or optimisation of resource usage. Dealing with technological aspects locally is usually sufficient for traditional process planning. For thin-walled products, this is not necessarily the case.

The step-wise approach of manufacturing thin-walled geometry is a strategy that can be generalized. It can be used at different levels. It can be put into practice on a low level, for machining of a thin wall, or on a high level, when planning operations for a thin-walled product as a whole.

The next subsections will go into the possible role of strategies at different levels. Also the role of related process planning tasks are discussed.

Strategies on tool path level

Tool path strategies usually refer to the ways in which generated tool path patterns will remove material; zigzag, helical outward, 3d z-level roughing.

Tool path strategies can help create similar machining conditions on both sides of a wall. Approaches like 'waterline machining' (see figure 2.13(a) in section 2.2.2) are typically suitable to achieve that. Apart from that, the approaches provide a degree of local support at the point of machining. So it is a possibility to try to capture such approaches in tool path algorithms.

However:

- Some of these approaches apply an overlap between passes on opposite sides of the wall (see figure 2.13(b) in section 2.2.2). This can be difficult to capture in a tool path algorithm.
- Some walls or other thin geometry cannot be machined with the mill's periphery due to geometric accessibility. It is desired to have an approach that can achieve the same for end milling, but also this can be complicated to capture in a tool path strategy.
- In traditional tool path strategies, it is indicated which volume or area must be machined (removed). In order to deal with stiffness issues properly, thin wall tool path strategies would in addition to that need information about the geometry that remains in order to reason with its stiffness properties. Moreover, in order to really deal with the stiffness, the strategies should be provided with much more reasoning capabilities and more input.
- The scope on which tool path strategies are potentially capable of dealing with stiffness remains limited to local geometry, like a single wall.

Strategies on operation level

Strategies on operation level refers to the choice of operations; the determination of machining methods to manufacture particular geometry. The methods (or the choices between them) are the strategies. Choices can be to machine geometry with one operation or with more than one (roughing and finishing), or to combine geometries to machine them together instead of separately.

Machining of a thin wall can be spit up into multiple operations at both sides of the wall, with such a sequence that alternate machining of the sides results. Such an approach makes overlap between volumes on opposite wall sides possible, as well as step-wise end milling of the wall. The scope is thus at a higher level than that of tool path strategies. It is rather on the level of geometric shapes instead of tool paths. Also, choosing to combine geometries and machine those together makes that the scope is that of a couple of geometric shapes instead of a single shape.

The choice of operations usually involves a choice on finishing and/or roughing operations. When machining thin walls, it is often a bad idea to first rough the entire wall and then finish it. During finishing, the wall is virtually thin-walled in that case, which compromises the step approach, because it becomes prone to damage. However, finishing conditions are necessary when machining product geometry, especially in case of thin walls. The alternative to use only finishing operations (and conditions) when machining thin walls appears unattractive, as it is time-consuming and inefficient. Another alternative is to combine finishing and roughing in a single operation which performs roughing and finishing for each depth step.

Although treating the problem on operation level appears to be better than on tool path level, still two sets of information are needed for a single operation; both about the volume to be removed and about the geometry to remain. Also, the scope on which operation strategies can deal with stiffness remains limited. The scope may be that of (considerable) sets of geometric elements, but not the product as a whole.

Operation sequence level

As noted before, the sequence in which volumes of material are removed is a key factor in dealing with low workpiece stiffness during machining. The sequence is important on the same level as the thinness; it can remain limited to a single wall, but it can concern the whole product as well. Stiffness issues can require that particular sequences of volume removal must be enforced. Operation selection cannot achieve this on product level, so this it preferably needs to be resolved by other tasks.

Operation sequencing itself is an optimisation task. Optimisation is done with respect to time, for instance, within a set of constraints and conditions which are known on beforehand. Enforcing sequences (constraints) should thus be done before rather than during operation sequencing.

Strategies on feature level

Using features in product model interpretation for process planning is a proven approach, as form features can be related to engineering knowledge of interest. For process planning, this knowledge usually concerns manufacturing strategies. For traditional machining, the knowledge concerns the material removal strategies; the operation methods discussed earlier.

The dual concerns - stiffness on one side and manufacturing on the other - show a parallel with the multiple view problem on features described in section 2.3.3. A process planner finds removal features useful for his task. A designer will reason with e.g. stiffness, especially for thin-walled parts. In his designing environment, features with a stiffness meaning will often be most appropriate.

One of the problems on both the discussed tool path and operation levels is that two interpretations of the geometry are desired. This is in fact because one is dealing

with two kinds of problems - multiple views. Information about the volume that remains is needed to deal with the stiffness issues, information about the volume to remove is necessary to solve the machining aspects.

As multiple viewpoints on the geometry are needed, feature kinds for each viewpoint can be used. In other words, the step-approach can be expressed in terms of features. A thin wall can be considered as a feature with stiffness meaning. The volumes to machine on alternating sides of the wall can be seen as machining features in the traditional sense of the word.

Following this frame of thought, a (stiffness) strategy on feature level can be viewed as a method that states how a portion of product geometry - expressed in terms of features - can be manufactured properly in terms of features to remove and sequence constraints between them.

Such an approach has the following advantages:

- Machining issues and stiffness issues can be handled separately to a large extent. Machining knowledge and strategies can be associated with dedicated machining features. Stiffness-related manufacturing knowledge and strategies can be associated with dedicated stiffness features.
- By separating the issues, reuse of existing process planning concepts and functionality is better possible. E.g. machining operation determination remains closer to its original form.

However, this is still on the level of a couple of geometric shapes; the scope is still limited to a portion of the product. Stiffness can be a product-level issue, which means that in that case it will also need to be handled on product level.

Strategies on product level

In case the whole product - or a very large portion of it - is thin-walled, stiffness issues must be considered on product level. One way to do so is to reason with the physical structure of the product. Features with stiffness meaning can be used as building blocks for such reasoning. Information is then needed on how these features are connected to each other. With this information, it becomes possible to analyse stiffness aspects of the product without resorting to FEM analyses. The stiffness knowledge of the individual elements (features) can be combined with stiffness-related manufacturing knowledge of the structure to provide sufficient stiffness support during machining on product level. The result of the reasoning should be that a collection of volumes, that provides sufficient support, is machined according to proper sequence constraints, to ensure top-down machining for the product as a whole.

There is also an entirely different approach which is an option. This will be referred to as the layer approach. It bears similarity with the idea of 'waterline machining', but on product level. The idea behind this approach is to 'peel off' the product layer by

layer; see figure 3.1. Each layer is then machined before the next is started. A layer then becomes the element under analysis; both the material to remove in the layer and the geometry to leave intact.

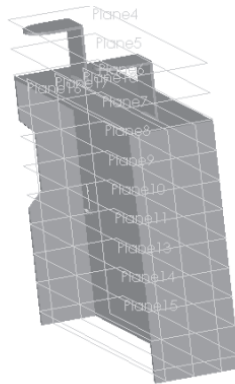

Figure 3.1: Possible layer subdivision for a product.

The following issues arise for this approach:

- It seems most logical to determine the thickness of the layer based on product stiffness. In that case, it is still necessary to do some stiffness-based product-level analysis. On the other hand, accessibility of geometry to machine must be kept in mind during such determination.
- If focus in a layer is on the material to remove, problems may occur because too little attention is paid to stiffness. If 'stiffness features' are considered per layer, they may be spit up into smaller ones, and consequently may not be dealt with correctly. If stiffness features are considered as a whole, the way to manufacture them may need to be divided over multiple layers. Shortly, it appears to combine poorly with the feature approach that uses multiple feature views.

3.2.4 A process planning task division for HSM for thin-walled parts

The way that process planning responsibilities are distributed over tasks reflects the general approach and frame of thought behind the process planning. Therefore, the chosen concepts and task responsibilities will be described in a top-down manner, starting with the main frame of thought.

The value of a stiffness-based manufacturing approach is great for thin-walled machining products. The proper scope of such an approach can vary from tool path level to product level. Furthermore, different kinds of problems are probably solved easier if

they are dealt with separately rather than together. Technically speaking, the core issues in process planning for high-speed milling of thin-walled products are stiffness issues and machining technology issues. It has been noted that process planning must take on a stiffness viewpoint on the product in order to deal with the stiffness issues. The previous paragraphs have deliberated upon ways to realise this on different levels. Especially on a low level, it is more difficult to separate stiffness issues from machining issues. On feature level, typically, it is possible to separate these issues to a large extent. Moreover, expressing stiffness-based manufacturing strategies in terms of features offers a very convenient point of separation; the results of applying the strategies are machining features to remove. So, from that point on, existing process planning concepts and functionality can be used as before, with relatively limited adaptations. This is not only convenient from the point of process planning concepts and software development, it is also comprehensible to a user - a process planner - to learn and use.

The general approach is therefore to deal with stiffness issues first, roughly speaking, and express the results thereof in terms of machining features and sequence constraints between them. New separate tasks will bear this responsibility. Nevertheless, reasoning will remain necessary in which both stiffness and machining issues play a role and interact. So other tasks will be adapted to incorporate this as well as adaptations concerning high-speed milling technology.

Feature level

As noted, features provide a good boundary to separate issues regarding stiffness and those regarding machining to a large extent. Also, features are typically entities that can be associated with knowledge and strategies. A wall can for example be related to stiffness formulas to determine the sizes of the volumes to machine around it. A strategy can be a waterline machining-like approach; it determines the volumes to use and their order of manufacturing. Another feature type, like for example a large hole in a wall, will need another stiffness-based manufacturing approach. For a large hole, the volumes to remove in and around it require a specific sequence in order to prevent vibration damage on the wall just above the hole. Other examples are available; the point is that different (combinations of) features require different manufacturing strategies, and that features provide a good vehicle to convey them.

Product model interpretation will thus start with determination of features. Geelink has argued why feature recognition is the most suitable form of feature determination for CAPP [Geelink 1996]. The difference with traditional CAPP is that feature recognition must look for features with stiffness meaning rather than volumes to machine. Such features can be both thin protrusions that have low inherent stiffness, or depressions that have a weakening effect on the workpiece. These features will from now on be referred to as stiffness features. Through knowledge-based reasoning with the features' stiffness and application of manufacturing strategies, a sequence of volumes to machine results; features with machining meaning. These 'traditional' CAPP features will be referred to as removal features or machining features.

Product level

Dealing with stiffness issues on product level largely comes down to applying the step-wise way of machining on product level. In other words, the product as a whole must be manufactured top-down.

One manner to achieve this is applying the layer approach. Another more feature-based manner is also possible. The machining features determined for specific stiffness features can be considered to belong to (be owned by) these stiffness features. Sequence relations for stiffness features can be considered to be in force for the machining features belonging to them. In other words, a stiffness feature sequence can be interpreted as a sequence of machining feature groups. The right sequence relations will result in top-down manufacturing of the product.

When comparing the layer approach to a purely feature-based approach for this scope, the layer approach adds little to no value:

- A form of stiffness analysis is needed to determine the layer thickness. Such analysis immediately brings stiffness features back into view.
- The approach is not very compatible with features, because a stiffness feature may be spread over multiple layers. This will very likely affect how these features are dealt with.

In favour of unification and compatibility, the choice is made to handle stiffness issues on product level through features as well.

Level of operations, tool paths and cutting conditions

As the step approach is largely enforced through features and their sequence, strategies on operation and tool path level can remain focussed on machining issues. Nevertheless, the thin-walled nature of the products do affect the responsible tasks. It was noted in section 3.2.3 that separation of roughing and finishing of a single volume may compromise the step approach. The risks of this resulting in inaccuracies is greatly reduced as stiffness is provided through other features. Still, combining roughing and finishing into a single operation results in more local stiffness support and will thus be safer. Such a combination is more efficient than applying finishing conditions for the whole volume. However, it is necessary to work with additional information about the geometry that is being machined, as finishing conditions are only necessary when machining product geometry.

On the level of tool paths and cutting conditions, tool path strategies can use the information to selectively use roughing and finishing conditions on different portions of the volume being machined. Both the thinness of the workpiece and the high-speed milling process dictate new conditions, especially for finishing.

Operation selection is for a large part responsible for determining when to use such combined tool path strategies and what specific conditions need to be used. This is hardly different from traditional CAPP.

Because the thinness of the workpiece rather than the cutting process is the main concern for accuracy, this is also for cutting conditions the main issue that will be addressed in this thesis, as it is in this entire process planning approach. Although cutting process instability can cause problems, an unstable (thin) workpiece is definitively a source of concerns. The role of cutting condition selection should therefore be attempting to guarantee a stable cutting process. Only when workpiece stability can be properly controlled through process planning, it becomes reasonable to experiment with cutting conditions for optimisation, for example through stability lobes. On the other hand, using cutting conditions to stabilise the process requires a certain predictability of the influence of process parameters on the accuracy of a thin part, when a CAPP system must do this. This predictability is very difficult and does not seem practically feasible at this point. This thesis will therefore focus on cutting condition measures that are known to have a positive effect on stability.

3.2.5 The role of knowledge

For traditional CAPP, knowledge-based method selection - operation determination for machining features - is a proven procedure (see section 2.3.5). This way of determining for a particular volume to machine what machining strategy to use and how to use it will therefore be used for CAPP for high-speed milling of thin-walled products as well.

A manufacturing approach that properly deals with low stiffness is a manufacturing strategy (method) as well. Choices between such strategies, and about their details, can depend on differing matters like combinations of geometry or sizes. A knowledge-based way of determining manufacturing strategies is thus also relevant on this level. The earlier example of a large hole in a thin wall reflects a manufacturing strategy that has proven itself in practice. Other situations, like another kind of depression in a wall, may require other manufacturing strategies. A knowledge-based approach leaves room for addition of new manufacturing strategies to a CAPP system. A company can add and extend manufacturing knowledge for better dealing with new and existing situations as it sees fit.

As noted in section 3.2.3 traditional CAPP tends to deal with technological issues on a local level. As made clear in previous sections, dealing with stiffness issues can require the scope of several stiffness features or even the whole product. Consequently, knowledge and knowledge-based approaches will generally have a larger scope for CAPP for high-speed milling of thin-walled products. This is especially the case because stiffness features and their knowledge generally interact more than machining features and their knowledge. This will be made more clear and elaborated upon in the following chapters.

Chapter 4

Manufacturing strategy knowledge for thin parts

This chapter focusses on domain-specific knowledge and how it can be formalised. The formalisation forms a basis of how this knowledge can be embedded in a computer-aided process planning system. Knowledge on three levels will be discussed. Section 4.1 focusses on feature level, where the main strategy is step-wise machining. It discusses quantification of the steps. It also provides relevant examples of variations of the approach from practice, to give a notion of the kind of situations that occur, and to gain insight in the knowledge structure. It concludes with a discussion on how knowledge should be expressed to apply such strategies properly. Section 4.2 follows a similar structure. It discusses the general strategy on product level, gives specific examples from practice and discusses formalisation of such knowledge. Section 4.3 discusses how knowledge on the level of operations about thin wall machining and high-speed machining can be translated into tool path strategies.

4.1 Strategies on feature level

The concept set out in the previous chapter draws a line between machining features and stiffness features. Strategies for manufacturing machining features will essentially deal with machining issues, strategies for manufacturing stiffness features will essentially deal with stiffness issues in manufacturing. Dealing with manufacturing stiffness issues of stiffness features will mostly be done by expressing manufacturing approaches for them in terms of machining features with a sequence.

Stiffness features are features with some kind of stiffness significance. These can be thin protrusions like walls, that have low inherent stiffness. They can also be depressions that have a weakening effect on the workpiece, like a hole or cut-out in that wall. The core issue is that one needs to describe a manufacturing approach that deals with the stiffness risks of that feature. This is why a large hole in a wall is a better candidate to be a stiffness feature than a thin-walled pocket. In the case of the thin-walled pocket,

dealing with its stiffness issues is probably more straightforward when reasoning with the thin walls that make up the pocket.

Stiffness features can have different sizes and shapes. Also, due to their nature (types), these features intersect more than machining features in traditional CAM, geometrically speaking. These geometrical intersections can have a weakening or strengthening effect upon other features. These effects can also need dealing with in manufacturing strategies. A large hole in a wall, for example, can require that that wall is machined in smaller, more careful steps. Such a situation requires an adapted strategy. The strategy may require even more adaptation if there is also a large cut-out in the top of the wall. So, stiffness features also interact more upon manufacturing strategy level. Dependencies are rather common. Making the selection and application of strategies a knowledge-based task allows different strategies to be applied to to different situations, also situations that are currently not foreseen. A company can adapt strategies for stiffness features to shapes and sizes of these features, but to new combinations of stiffness features as well.

When strategies are applied upon stiffness features, they must

- deal with stiffness issues,
- deal with dependencies between connected stiffness features.

Preferably, machining features should be shaped, sized and placed with optimisation in mind, so that e.g. they can accommodate a whole number of cuts. This shows a dilemma, because the total volume to be machined is subdivided into artificial subvolumes, before the tools and tool paths are selected. If subvolumes are subsequently planned individually, there is a risk that the actual resulting tool paths become inefficient. Knowing the final tool paths, one might opt for another volume subdivision. This dilemma is also present in traditional CAPP systems, where often different alternative artificial subdivisions of the volume to machine are possible. Although relevant, in this research this dilemma is secondary to stiffness-related accuracy issues.

The remainder of this section will go into knowledge for dealing with stiffness features. Manufacturing strategies for stiffness features are reviewed for determining what is needed to express these strategies formally, in a knowledge data structure. Special attention is paid to the qualification and quantification of the core strategy, the wall-level step approach.

4.1.1 The step approach

The step approach on wall-level is very similar to the wall machining approaches commonly found in literature (see section 2.2.1). The difference is that those wall machining strategies are expressed in terms of a sequence of tool paths, whereas the step approach envisioned here is expressed in terms of a sequence of machining features. In other words, larger volumes are considered. Figure 4.1 shows the idea of the approach. The numbers indicate the sequence in which the machining features are removed.

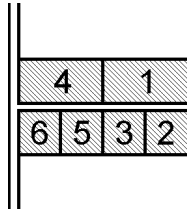

Figure 4.1: Step approach for a single wall.

Alternately machining the wall sides is an obvious characteristic to be seen in the figure, but so is the fact that machining features on one side of the wall are larger than those on the other side. When these large features are machined, there is still workpiece material on the other side of the wall, providing support. Larger features can be machined more efficiently, because tool paths within the feature will be better optimised than for a set of smaller features covering the same volume.

Tolerances are a measure of the allowable deflection of a wall during machining. Machining features are supposed to restrain this deflection, so their sizes depend on the stiffness of the wall at hand. On the other hand, these machining features are influenced by machining issues (efficient tool path distribution) with respect to size as well as by connected stiffness features with respect to sizing, positioning and sequence. A lot of strategies can be considered as an adaptation of the step approach of the wall to which a feature is related. These issues are discussed in the subsequent subsections.

4.1.2 Stiffness knowledge

This section discusses knowledge for determining machining feature sizes. This knowledge is predominantly stiffness-based, but involves machining influences as well.

Stiffness theory

Machining features need to provide local stiffness to prevent exceeding the tolerances. To determine when machining features provide sufficient stiffness, i.e. with what sizes, some form of calculation model is needed. It has been chosen to base this model upon the stiffness of standard straight walls. Common thin-walled products at Fokker Aerostructures can be viewed as built up from a set of walls, and, as will appear in section 4.1.3, walls often form the core of their manufacturing strategies. The resulting machining features help armour the workpiece geometry against inaccuracies due to

- bending deflections,
- vibration re-machining; overcutting of the workpiece due to the vibrating wall hitting the cutting tool, depicted in figure 4.2,

- regenerative vibrations from the machining process,
- resonance due to hitting a natural vibration mode of the workpiece geometry.



Figure 4.2: Vibration re-machining, after [Tlusty et al. 1996] (reprint of figure 2.6(a))

In section 3.1, it was already noted that calculation on the last two phenomena is difficult. In addition, at this stage of process planning, the exact process conditions are unknown. The added support can however help reduce the resulting workpiece vibration amplitudes.

Vibration re-machining is also difficult to analyse, because the source of the vibration is unclear. Perhaps the phenomenon results from natural wall vibrations, but it is conceivable that bending also plays a role. If tool and/or wall deflect elastically due to bending, the resulting workpiece geometry can be thicker than specified. For a subsequent deeper tool pass along the wall, overcutting of that thicker wall portion can then occur more easily. This effect may not necessarily be cause of the phenomenon, but it is at least a negative influence.

Nevertheless, apart from these considerations, bending is the main issue, because it can cause the greatest deviations. Deviations (deflections) due to bending result from the *nominal* cutting force, whereas deviations due to vibrations result from *variations* in the cutting force. Bending problems in milling often consider accuracy in terms of tolerances, whereas vibration is often associated with surface finish.

For the model to be practically usable in a process planning system, the calculation complexity must be limited. Therefore, finite element calculation are omitted, as are iterative approaches in which workpiece geometry is updated in accordance with material removal. Preference is given to an approximation based on a worst-case situation.

The geometry for the model is based upon the situation depicted in figure 4.3. Based on the step approach from section 4.1.1 and figure 4.1, figure 4.3 shows the situation in which the most bending will occur, because the bending moment is largest. The first large machining feature has been removed, and machining of the first small machining feature is nearly finished. Machining is assumed to take place at the top of the wall, and the cutting force is assumed to act at the top of the cut; both these assumptions are for both safety and simplification of calculations. The workpiece material on which the wall stands is considered rigid.

For calculation on bending, this situation corresponds with a cantilever beam problem, in which the beam consists of three sections that will bend differently. Superposition of

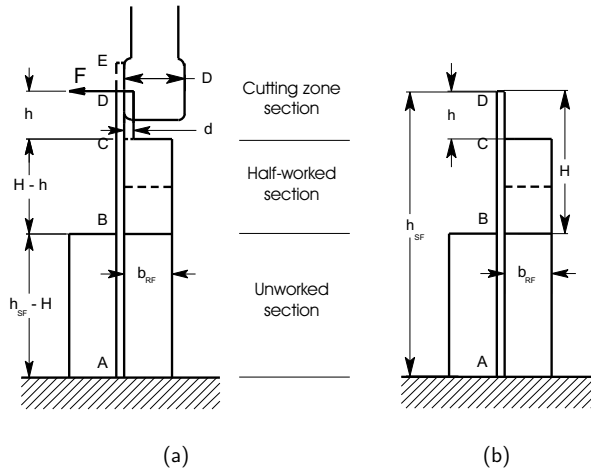

Figure 4.3: Depiction of the bending model for machining feature size determination, shown for peripheral milling; after [Ouwkerk 2003]

bending of the various sections gives a total deformation picture. However, the actual situation is rather a plate deforming due to a point force than a beam with a force distributed evenly along its top. As noted by Van Ouwkerk [Ouwkerk 2003], the wall will deflect locally. Figure 4.4 illustrates the difference in modelling. In a cantilever beam problem, deflection is supposed to be uniform along the beam length, and resistance to bending (through inertia) increases with length. As bending occurs locally, the effect of a different length upon wall stiffness at some point becomes negligible. According to [Timoshenko et al. 1959], when a force acts on the top of a wall of constant thickness and away from loose ends, deflection is ten times smaller at a distance in the length direction of twice the height of the wall when compared to the deflection at the point where the force acts. Van Ouwkerk [Ouwkerk 2003] therefore proposes to use an effective length, which equals a multiple of the wall height, to take this into consideration in beam bending calculations. If the real length of a wall exceeds this effective length, calculations must use this effective length instead.

The calculation model was set up by Van Ouwkerk [Ouwkerk 2003], and considers bending due to a load equal to the maximum milling force as depicted in figure 4.3. Deflection at point E is the limiting factor and is based upon used tolerances. Because Fokker Aerostructures takes vibration re-machining very seriously, it is also considered in the model. Namely, point E represents the top of the cutting portion of the tool; the highest point on which vibration re-machining can occur. This point is in fact *above* the wall. Wall section DE thus represents the (virtual) height of the wall above the force that can potentially hit the tool. In other words, deflection of a slightly higher wall is considered. Although the model is somewhat unrealistic in the sense that it does not represent a practical situation, it combines easier calculation with additional safety; it

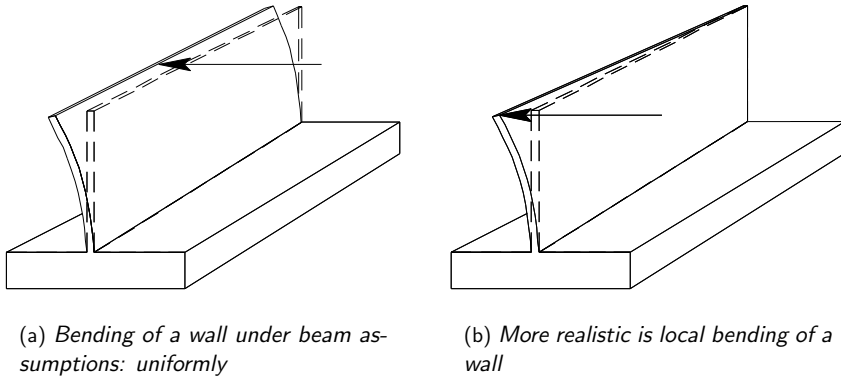

Figure 4.4: Bending of a wall.

implicitly assumes more deflection.

When applying large machining features on one side of a wall and small ones on the other, additional caution is needed for the following reason. Asymmetrical machining can lead to thin-walled geometry tending to warp, as discussed in section 3.1.3. Such internal stresses may find their cause and thus a possible solution in the usage of certain cutting conditions. But as dealing with such influences is difficult in practice, conservative sizing of these large features out of safety needs to be applied.

Tolerances

As noted earlier, tolerances are measure of the allowable deflection of a wall during machining. The tolerances that are used for a product need to be interpreted to determine how much deflection is actually acceptable. For the Fokker Aerostructures products relevant for this project, steering tolerances are surface profile tolerances. The profile of a surface is the condition permitting a uniform amount of profile variation on a surface [ISO 1983]. The tolerance zone can be described by a volume which is bounded by two surfaces, defined by imaginary spheres of diameter t whose centers lie on the theoretically exact geometrical form; see also figure 4.5.

The tolerance values used by Fokker Aerostructures are usually symmetrical about the surface. So wall deviations are allowed up to the size of half the profile tolerance zone, with respect to the nominal wall profile. In other words, for the calculation model described above, if no safety factors are considered, the maximum allowed wall deflection is equal to half of this tolerance value t . Other tolerances could lead to other interpretation of their values for use in stiffness calculations.

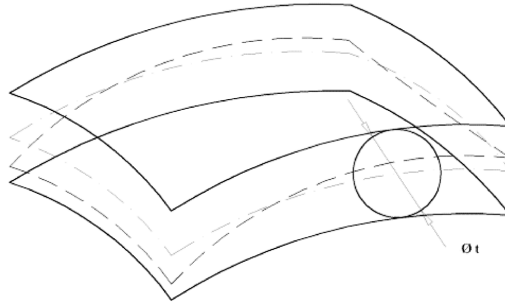

Figure 4.5: Depiction of the tolerance zone for profile of a surface, after ISO 1101 [ISO 1983].

Machining knowledge influences

Machining features must provide sufficient support to stiffness features, but they must also be machinable, preferably efficiently. If possible, sizes must be chosen in such a way that an optimal set of cuts fits within a feature. Machining feature sizes are therefore rounded to a whole number of preferred cuts, or rather, they are rounded based on assumptions that will generally result in relatively efficient cuts (which will be optimal for standard cases). These assumptions depend upon cutting tool diameter, milling style (face or peripheral) and the type of tool passes used (roughing or finishing). The rounding rules inventoried for Fokker Aerostructures by Van Ouwerkerk are listed in table 4.1.

Peripheral milling, width	finishing stepover * tool diameter + n * roughing stepover * tool diameter
Peripheral milling, heights	n * roughing depth of cut (possibly tool dependent)
Face milling, width	finishing depth of cut + n * roughing depth of cut (depths of cut possibly tool dependent)
Face milling, heights	n * finishing width of cut = n * (half the tool diameter + 1), based on a Fokker Aerostructures rule of thumb.

Table 4.1: Machining feature size rounding for Fokker Aerostructures, after [Ouwerkerk 2003]. Widths are rounded up, heights are rounded down.

The assumptions lie not as much in the rounding rules - they are quite general - as in the values used. Machining feature sizes are chosen before the operations that machine them are known. A company thus needs to determine on beforehand what values need to be used for this rounding, like a preferred tool diameter and roughing and finishing depths of cut and stepovers, based upon machining experience. Size calculation itself must preferably remain open to use different (adjustable) values for different situations.

How efficient the final tool paths are depends on operation choices, which may well involve other tools or cutting conditions than those assumed preferable here.

In addition, several other machining influences are present in the size calculation model [Ouwkerk 2003]:

- In the model, the height potentially affected by vibration re-machining is incorporated (as virtual height increase of the wall). This height depends upon the cutting length of the tool for peripheral milling, or upon the tool diameter for face milling.
- The magnitude of the bending force must be based on machining practice. Given the situation upon which the model is based, this value is based upon the maximum force experienced in simulations by Fokker Aerostructures when machining near the product surface.

These influences also are to be adjustable in size determination, in order to take differences in machine and cutting tools into account.

Practice

Two issues are important with respect to practical usage of the discussed theory and knowledge:

- the actual determination of machining feature sizes from the discussed modelling;
- the practical validity of the model; determination of parameter values based upon data from practice.

The modelling has been performed with machining feature size determination in mind. The relevant parameters, being the machining feature width (B_{RF}) and heights (h and H) can be found in the geometry of the model in figure 4.3. As noted before, the sizes are determined based upon bending due to a load equal to the maximum milling force. From tolerances, the maximum allowed deflection can be derived. In addition to the model's worst case approach, a safety factor is used, among other things to reckon with dynamic phenomena not incorporated in the model. It is chosen to put this safety factor with the allowed deflection.

The bending model has one equation from which three unknown size parameters must be determined. Therefore, the sizes are calculated in an iterative way. The iteration calculations are based upon steps using rounded feature sizes and proceed as follows. All machining features are initialised based upon rules of thumb. The width B_{RF} is initialised using a stiffness-based rule. The initial h is based upon a multiple of finishing cuts, which differs for respectively face and peripheral milling. The initial H equals a multiple of h . H is preferred to be a multiple of h in general, so that machining features on both sides of a wall will be aligned. The bending deflection is calculated based upon these initial values. While the deflection is larger than allowed, h is decreased in steps

equal to the size of a finishing cut and deflection is recalculated each step, with a lower boundary of h being equal to at least one finishing cut. When h is changed, H is reset to a multiple of h . In case the deflection continues to be too large, the width B_{RF} must be enlarged. When the deflection is lower than the allowed value, H is increased in steps of size h and deflection is recalculated. This iteration stops when the maximum deflection is exceeded or when H becomes larger than the wall height, so that a maximum value of H results.

Practical validity of the size model in this process planning context concerns its practical usability. In other words, correspondence of the values with reality is of more importance than the theoretical correctness of the model. The nature of the model is mechanistic¹. For this reason, milling tests have been performed at Fokker Aerostructures, to tune the model so that it results in practically valid sizes. The milling tests are described in appendix section A.1. The tests showed a clear influence of the machining feature sizes upon the manufacturing results. Cutting conditions (especially depth of cut and spindle speed) however did influence test results as well. The tests remained limited to peripheral milling.

In appendix section A.2, the model parameter values are listed that are used in practice. The maximum milling force is based upon the maximum force experienced in simulations by Fokker Aerostructures when machining near the product surface [Ouwerkerk 2003]. The roughing and finishing sizes of the cuts are based upon process planning experience. Preferred cutting tool properties are based on those commonly used for finishing thin walls at Fokker Aerostructures. The effective length factor is based upon theory first and tuning the model second. The chosen value for the allowed deflection gives good mapping of the model on the feature tests and gives a substantial safety factor with respect to the tolerance.² The generally used tolerance at Fokker Aerostructures is a surface profile tolerance of 0.127 mm. The theoretical allowed deviation without safety is half this tolerance, i.e. 0.0635 mm. The chosen allowed deviation of 0.01 mm thus gives a safety factor larger than 6 in this case.

4.1.3 Manufacturing knowledge

The strategies discussed in this section are based on guidelines and approaches used by Fokker Aerostructures, which have been formalised and generalised by Van Ouwerkerk [Ouwerkerk 2003]. They are examples of the some of the most relevant geometric situations encountered in their products.

¹"Mechanistic models are the middle ground between analytical models and empirical models. The mechanistic approach utilizes knowledge about the underlying mechanisms of the phenomenon at hand to propose models with some calibration constants. The values of these constants are found through experimentation." [Monreal & Rodriguez 2003]

²Note that 'good mapping' is not meant in the sense of predicting bending deviations correctly, but in the sense of calculating machining feature sizes that gave good (sufficiently accurate) results in the tests.



Knowledge examples

Where section 4.1.1 describes the general step approach, this section will go into manufacturing rules that affect how the approach is applied. It will appear that connected stiffness features can be a significant influence. When such physical connections are mentioned in this section, they will generally refer to cases where one feature can be considered to be *on* or *in* another feature. (Another type of connection is a *crossing* of two walls.)

The following rule examples are general ones that help decide on which side of a wall the large machining features should be.

1. Horizontally oriented wall features should have the large machining features, that will be machined first, on their up side. This is consistent with top-down manufacturing of the product as a whole.
2. Large machining features should be on the side of the wall to which the most other stiffness features are connected. This means that this side of the wall, which will usually be the more complicated one, will be machined while there is still support from the machining features on the other side.

Connected walls

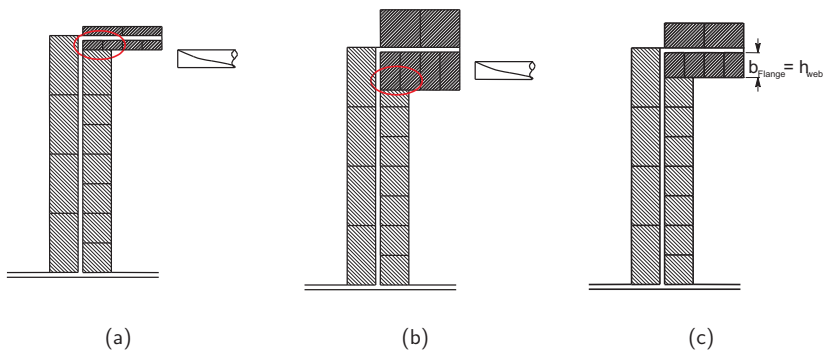

Figure 4.6: A situation with too narrow (a), too wide (b) and correctly sized (c) wall machining features; after [Ouwkerk 2003]

Besides orientation, walls also affect machining feature sizes of connected walls. Namely, sizes of machining features of one wall may not cause machining feature size restrictions on another wall to be exceeded. See figure 4.6 as an example. Machining features of the flange will be machined first. If these features are too narrow (figure 4.6(a)), the tool will not be able to reach the bottom of the slot features. The last flange feature however also machines the large web. If this is too wide (figure 4.6(b)), the permissible height on that side of the large web is violated. The proper flange

machining feature width is in this case the permissible height for the web (figure 4.6(c)). Such situations are quite common. (If the machining feature size adaptation results in too little support - too small walls - for the flange, the size adaptation can be applied more locally: only up to the width of the web's machining features, the region indicated by the ellipse in figure 4.6(a).)

Cut-outs

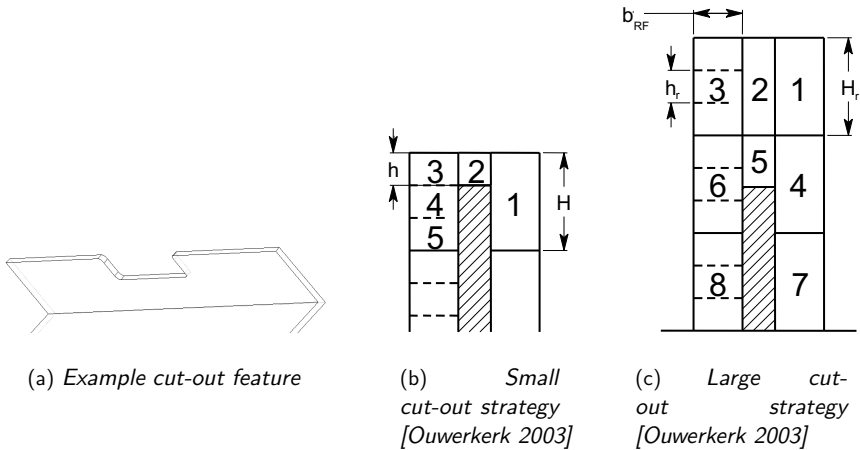

Figure 4.7: A cut-out and schematic views of cut-out manufacturing strategies.

In Fokker Aerostructures products, rows of cut-outs occur regularly in flanges. Their depths are often equal, but this is not by definition the case. If the cut-outs are small - less deep than the short permissible height of the wall - the associated machining feature of the cut-out only has to be 'inserted' in the wall machining feature sequence. This can be seen in figure 4.7(b) (in this case, the sequence of machining features 2 and 3 can optionally be switched). For one or more large cut-outs, the integration of the cut-out strategy in the wall step strategy results in more severe changes. Due to the weakening effect of the cut-outs on the wall, the sizes of the wall machining features should be changed. It is best to base this on the shortest distance between two cut-outs, or a cut-out and the edge of the wall: the length of the short wall that results. Van Ouwerkerk chooses to use the ratio of this length and the cut-out depth as input in the wall machining feature size calculation [Ouwerkerk 2003]. The cut-outs will take over the larger of the permissible heights of the wall, see figure 4.7(c) (the blocks on the left represent three stacks of three small machining features). The only restriction is that the bottom machining feature, number 5 in the figure, may not become too thin to machine.

Holes

Rows of large holes can occur regularly in large walls. Their sizes often differ and they are not necessarily horizontally aligned in the wall. Again, if the depression is small,

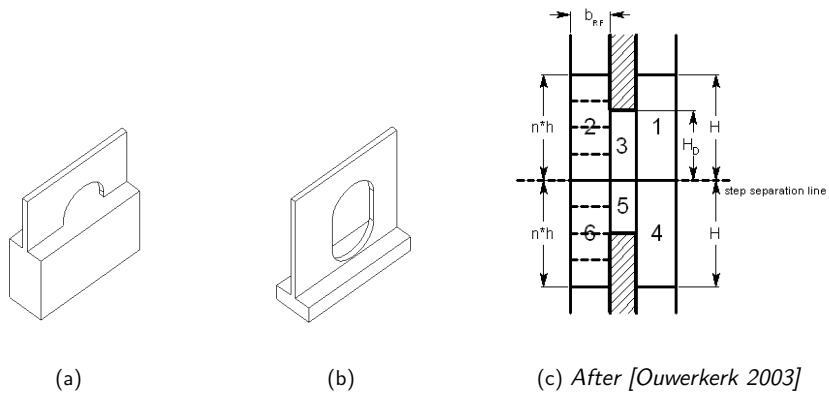

Figure 4.8: Manufacturing a large hole in a wall.

it only needs to be fit into the sequence of the surrounding wall machining features. They should be machined as soon as they are exposed on one or both sides, so that the remaining wall machining features provide support. A hole is considered large - and needs to be machined in more than one step - when its height exceeds 1.5 times the tool diameter. The criterion comes from manufacturability of the first step of the hole; this must be sufficiently large to allow for a tool entry. Large holes are manufactured in a specific sequence of steps, as shown in figure 4.8. For the upper half, machining the hole itself last is necessary. Otherwise there is a large risk of vibration marks on the wall near the hole, exceeding the tolerance. For the lower half, machining the hole last is not strictly necessary. This strategy requires more careful insertion into the wall's step strategy. As accessibility of the upper hole half is an issue, the position of the line that separates the upper and lower hole halves is important. In case of a row of holes - figure 4.9 shows a typical example - this line must preferably be aligned for all holes, because then it can be aligned with the wall's machining features, as can be seen in figure 4.8(c). Van Ouwerkerk refers to this as the *step separation line* and considers the preferable position to be at a distance of twice the tool diameter from the top of the highest hole in the wall [Ouwerkerk 2003]. (If the lower half of a hole exceeds the large permissible height of the wall, that hole machining feature is split again.) Fokker Aerostructures does not adapt wall machining feature sizes in this case because they have not experienced problems despite the weakening effect that the holes would seem to have. Another company could have other experiences and therefore choose to adapt sizes.

Chamfers as an example of geometrical details

There are several kinds of geometrical details that frequently appear on stiffness features - also over different types. Although they are details, such as chamfers, fillets or corners, they can require a special machining approach and therefore a separate operation - and thus a separate machining feature. This depends on the manufacturing knowledge.

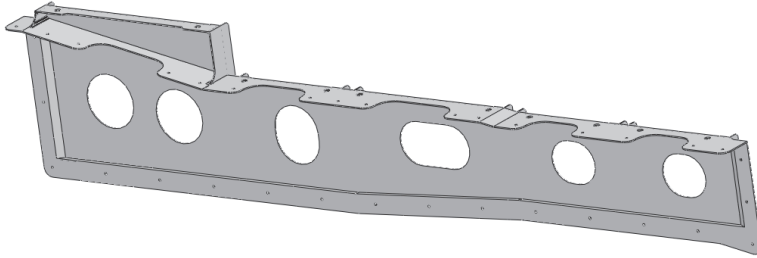

Figure 4.9: A Fokker Aerostructures product with multiple large holes.

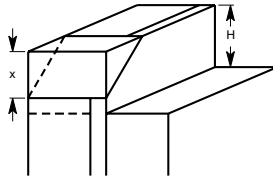

Figure 4.10: Manufacturing feature approach for a chamfered rib, after [Ouwerkerk 2003].

For example, when looking at a chamfer on a wall as shown in figure 4.10, whether it is on a flange, rib or other type of wall will most probably not matter for the way the chamfer itself is machined. In that sense, the chamfer is a feature that stands in its own right.

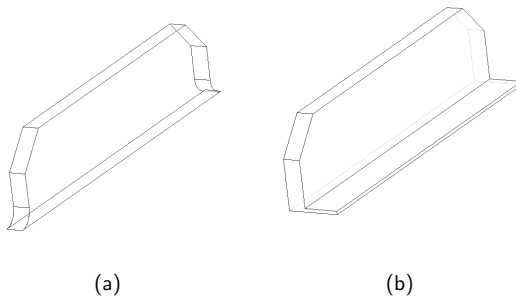

Figure 4.11: Ribs with multiple details

The two ribs in figure 4.11 show combinations of geometrical details. Even more combinations can occur. One end of a rib can have a chamfer while the other end has a fillet, et cetera. These aspects give reason to consider details as separate stiffness features with their own machining features. The stiffness features in figure 4.10 are better presented as CHAMFER and RIB instead of (single feature) CHAMFERED_RIB, for

example. Separating the details from their stiffness features also prevents a proliferation of stiffness feature types.

The preferred sequence of machining of the chamfer can be seen in figure 4.10. In case the chamfer is large, the preferred sequence of machining can be to machine the chamfer before all wall machining features.

More knowledge examples are conceivable, like locally thin portions of a wall (shallow pockets), that can also require adapting the wall's step strategy. The provided examples however represent important cases that have the heaviest influence. The associated knowledge and its complexity are discussed in the following sections. What are the consequences with respect to making this knowledge available in a CAPP system?

Consequences - demands on knowledge expression

As the knowledge examples show, manufacturing knowledge for a lot of stiffness features is focussed on the thin-walled product geometry that directly surrounds such a stiffness feature. The core issue for each case is how the manufacturing of the stiffness feature can be fit into the manufacturing approach of the associated wall. As Van Ouwerkerk puts it, stiffness features like depressions will be connected to a wall; the strategy for handling such a connection will therefore usually entail a modification to the machining feature sizes of the wall and/or an integration of the strategy into the step method. Machining feature sizes are usually modified when the connected feature influences the stiffness of a wall. [Ouwerkerk 2003]

When generalising the influences of manufacturing strategies upon each other, the following dependencies can be discerned:

- the side of a wall on which the large machining features should be placed can be affected by connected features
- the size of wall machining features can be adapted based on connected walls, base walls in particular;
- the size of wall machining features can be adapted due to connected weakening depression features;
- machining features of depression features are often inserted into the sequence of machining features of the wall that they are in;
- the positioning of wall machining features can be adapted due to connected depression features (alignment);
- machining features of depression features can take over sizes of the wall machining features; which sizes these are depends upon the manufacturing sequence.

Shortly put, there are size dependencies, placement dependencies and sequencing dependencies. These strategy dependencies can occur combined and can be mutual, meaning machining features of both stiffness features are adapted.

Regularly, more than one feature occurs in or on a wall. In case of the same type of feature, like hole features or cut-out features that have a weakening effect, all of these feature instances in that wall must be considered. This way, the best overall adaptation for a wall is achieved: the best machining feature alignment in the case of large holes, for example. One of the difficulties is that little can be assumed about the number of feature occurrences that need to be taken into account.

Obviously, a wall instance can have features of different types in or on it. This was shown for geometrical details upon stiffness features in figure 4.11, but this is of course true for other features as well. A wall can have both holes in it and a flange on its top, which means that its step strategy is influenced by two different feature types. If possible, these different influences should all be effectuated. Influences (adaptations) can also contradict or obstruct each other. For those cases, the strategy adaptations should have priorities associated with them. Strategies that deal with the most weakening cases will generally take precedence.

Despite the fact that no operations are determined yet, tooling plays a role in the manufacturing knowledge that is applied. Some portions of the manufacturing approaches are based on accessibility of the tool used. This can take the form of sequence constraints, when features are sequenced to be manufactured as soon as they are exposed. But also kinematic capabilities of a machine tool can influence the machining direction chosen for particular stiffness features. In other cases, cutting tool sizes are important for knowledge decisions due to accessibility. An example is the criterion stating that a hole is considered large when its size exceeds 1.5 times the tool diameter. Also, as described in section 4.1.2, machining feature sizes are preferably determined with an efficient set of cuts in mind. So, at least assumptions are needed about the tooling to be used. It was noted earlier that when such knowledge is applied, it will use preferred tool properties instead of actual tool properties. In other words, no tool will be selected yet. Namely, first, machining features may be changed before operations are determined for them, in which case a pre-selected tool may prove to be less efficient. Second, the actual tool and its parameters are best chosen when the operations are determined, because the selection can then be better optimised for the resulting set of operations. The data will be more definite and therefore a better basis for such optimisation.

4.1.4 Expressing knowledge

Figure 4.12 shows the outside view upon the knowledge described above. A set of knowledge takes a potentially large input set, especially features, and generates an even larger output set of features and sequence relations. Typically, and as noted above, the number of features and the number of feature types in the input can vary; this will also hold for the output.

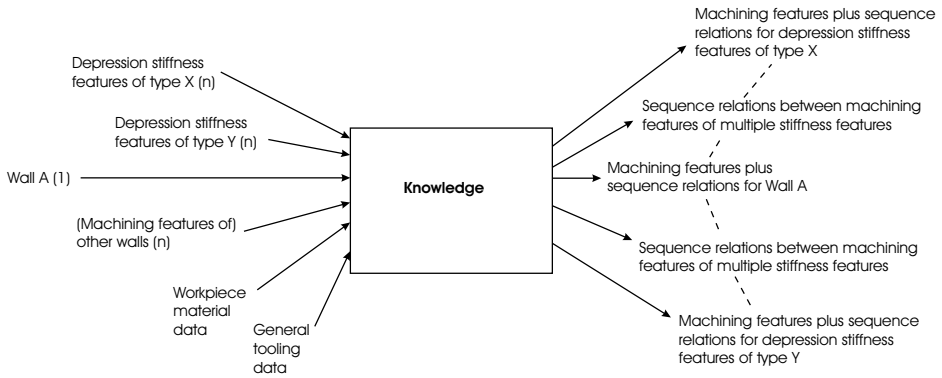

Figure 4.12: Outside view of a feature-level stiffness-based manufacturing knowledge set.

Figure 4.13 shows the form that the knowledge takes on; a flowchart-like structure in which the order of the elements depends upon the nature of knowledge dependencies and the priority of influences over other influences. If such a structure is to be kept flexible and adaptable, in other words, if a customer must be able to create and modify such knowledge sets, the structure must be of a modular form. Portions of knowledge should be expressed in such a way that they can be used as building blocks to create such flowchart-like structures. If for example the influence of large holes upon a wall is expressed as a separate block, it can be plugged into the knowledge set for ribs as well as that for flanges. Similarly, if influence priorities change, e.g. the influence of cutouts is suddenly considered more important than the influence of large holes, such blocks can be shifted in the structure.

Input, output and content of these knowledge blocks depends upon how the knowledge is structured exactly. The knowledge blocks can contain different kinds of functionality for a stiffness feature.

- processing its properties' influence upon its own output (being machining features and their sequence constraints),
- processing its properties relevant for influence upon output of connected features,
- exerting influence upon the output of connected stiffness features,
- accepting influence upon its own output from other connected stiffness features, and
- effectuating the influences on its own output.

For different feature types, the associated knowledge and thus the presence and order of this functionality can vary. Depending on the case, more than one kind of functionality

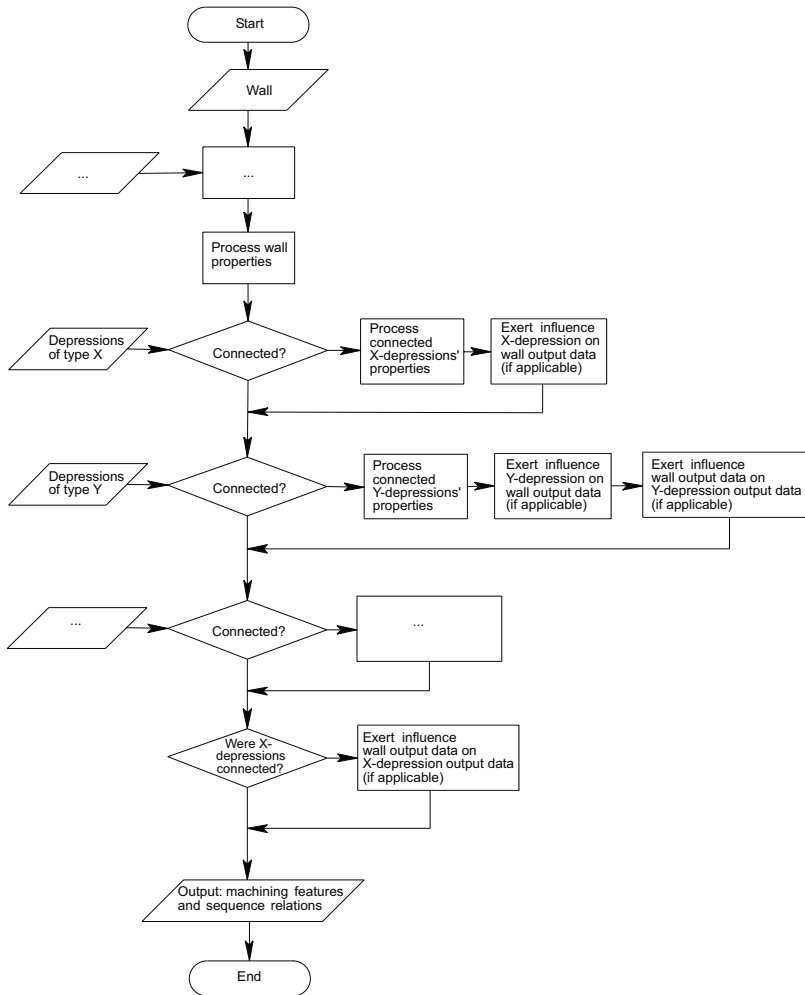

Figure 4.13: Inside view of a feature-level stiffness-based manufacturing knowledge set.

can be expressed combined in a single knowledge block, but from an flexibility viewpoint it is desired to keep them separated. For example, if connected stiffness features exert influence on each other's machining features, this mutual influence can be expressed in one knowledge block. If it is expressed in separate knowledge blocks, the influence in one direction can be shifted in the knowledge structure independently from the other, e.g. when knowledge priorities change. Such flexibility also requires some form of intermediate data to be passed between the knowledge blocks.

4.2 Strategies on product level

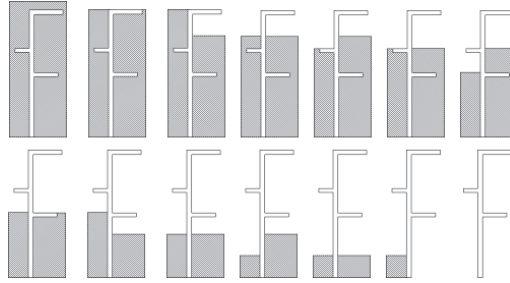

Figure 4.14: Rough depiction of top-down machining on product level.

As discussed in section 3.2, for thin-walled products, top-down manufacturing is needed, preferably step-wise. Preferably, an approach that tries to achieve this should be feature-based. This will make such an approach more compatible with approaches for other core issues, which also have a feature-based nature.

4.2.1 Stiffness feature sequence

The sequence of machining feature volumes is essential for thin-walled products, as appeared in the previous section on strategies on the level of individual stiffness features or a set of them. However, manufacturing strategies on that level will generally not incorporate all the stiffness features in a product.

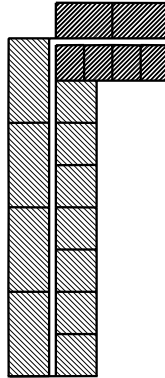

Figure 4.15: Machining feature groups for a simple product, discernible by their hatching.

Without additional measures, the result of application of manufacturing strategies as discussed in the previous section would thus result in groups of machining features. These machining features have sequence relations within the group, but not necessarily

between groups. In many cases, such relations will be desired. For the situation shown in figure 4.15, a logical approach would be to machine the features for the flange on top before the machining features of the large web.

This can be achieved through the idea mentioned in section 3.2.3: consider machining features determined for specific stiffness features to belong to these stiffness features, and consider sequence relations for these stiffness features to be in force for those machining features (groups) belonging to them. Which sequence relations are needed in which cases can depend on specific situations. A top-down sequence is the main goal, but specific manufacturing approaches can call for different measures.

4.2.2 Knowledge examples

The following lists situations in which specific sequence relations should be applied between stiffness features.

- In general, to enforce top-down machining, if a stiffness feature is positioned higher than another, it should be manufactured before that other stiffness feature.
- It is usually desired to manufacture a flange before manufacturing the wall that the flange is on.
- In case of a depression stiffness feature in a wall, like a hole or a cut-out, manufacturing them together - simultaneously - is generally desired, in conformance with knowledge discussed in section 4.1.3.
- When a rib is on another wall, and it is oriented roughly horizontal with respect to that wall, it is usually desired to manufacture the rib together with that wall.
- If a rib on another wall is oriented roughly vertical with respect to that wall, the rib is sometimes manufactured before the wall. This is only allowed if this doesn't endanger machining of the wall too much; it may not result in removing too much material that should provide support during machining of that wall. This could for example occur if multiple vertical ribs in a row on a wall are all machined before that wall.

4.2.3 Expressing knowledge

When examining the knowledge examples from section 4.2.2, a more or less general form can be distinguished. If two particular features comply with certain conditions, a sequence relation is to be applied between them. This can be considered as a kind of *rule*. The relation can be that one feature should be manufactured *before* or *simultaneous with* the other. The conditions can involve characteristics of either of the features, properties of those features in relation to each other, or in relation to their environment. First, the type of the features often plays a role. Second, the physical connections between

the stiffness features (and the nature thereof) is virtually always important. Moreover, information of connections of the features with other than the pair being considered can play a role. Characteristics like sizes can be involved; in case such sizes are used in stiffness calculation, it is conceivable that material properties are also of interest. Finally, data on position and orientation of the features with respect to each other is used. Important is that the relative position of features is used *in context of the workpiece's placement upon the machine*. This context is needed to enforce top-down machining.

It is conceivable that there are cases in which two rules can apply upon the same feature pair. Also, it is possible that a combination of a couple of rules applied on a couple of pairs results in a conflicting or even impossible situation, like a circular set of *before* relations. A resolution for problems like these is prioritising the rules.

4.3 Strategies on tool path level

This section will go into how knowledge on the level of operations about thin wall machining and high-speed machining can be translated into tool path strategies.

4.3.1 Combining finishing and roughing

As discussed in chapter 3, machining already thin-walled workpiece geometry more than once is undesired. It can cause the demanded accuracy not to be achieved because it compromises the step approach. As it is not efficient to constantly use finishing conditions for machining thin geometry, combining roughing and finishing within operations forms a potential alternative. For such operations, finishing paths and conditions can be applied only where necessary. Restrictive circumstances are then enforced locally. On one hand, this results in more optimal operations, which contribute to the capabilities of high-speed milling. On the other hand, this results in local differences in tool path patterns for these operations. Besides thin geometry machining conditions, considerations from the high-speed milling process or from an efficiency viewpoint can result in adapted tool paths.

The following subsections deal with the nature of these differences as well as the scope (level of detail) of the changes in tool paths they result in. They discuss relevant demands from the application area upon this level and consequences of these demands upon tool path patterns. Some specific envisioned patterns are discussed, as well as generalisation aspects. As indicated in section 1.5, focus is upon 2.5-dimensional geometry and thus upon 2.5-dimensional tool paths. The demands, considerations, theory and solution approach may be valid and applicable for 3D tool paths as well, but these are considered too complex to take into consideration in this thesis research. It is a common practice for 2.5-dimensional operations to create a 2-dimensional path pattern and to copy that path pattern for the necessary number of depth steps. The complexity of the operations will however increase due to the combination of finishing and roughing.

4.3.2 Tool path and cutting condition demands

This section focusses upon demands on operation or tool path strategy level. The focus is upon demands that are different from or complementary to traditional operation demands. The demands have been divided into three groups: demands coming from the machining process, demands coming from the thin nature of the workpiece and demands from an optimisation viewpoint. The list of demands is mostly based upon [Andringa 2001a], [Andringa 2001b] and [Hagen 2004].

High-speed machining demands

- Axial plunging must be avoided. High feedrates can cause axial overshoot and thus overcutting. Ramping or spiralling motions should be used instead, see figure 4.16.
- For the same reason, when a pass machines product geometry with the periphery of a mill, the motion to that pass should not be perpendicular to that product geometry. A circular or tangential run-up to product geometry is called for, see figure 4.17.
- Full cut passes need to be limited and mostly avoided. They result in higher cutting forces and more difficult chip disposal. This generally results in higher vibration risk and reduced surface quality. They cannot always be avoided however, for example in case of a closed contour feature such as a pocket. If a full cut is applied, the operation parameters need to be adjusted accordingly to counteract these effects; at least the depth of cut should be reduced.
- Sharp corners should be avoided and rounded up where possible. This results in less varying cutting conditions, in addition because less drastic changes in direction will result in less drastic decelerations and accelerations. Where needed, feeds and speeds need to be adjusted in sharp corners.

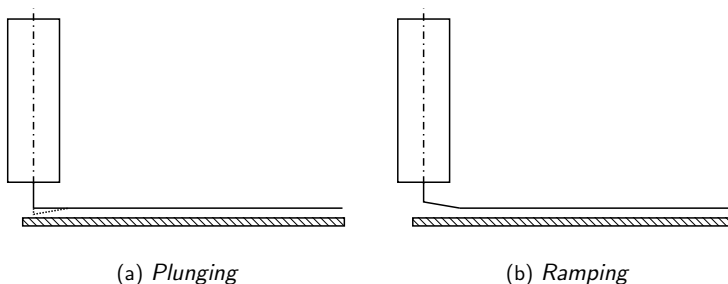

Figure 4.16: Careful axial motions near part geometry can help to prevent overcutting.

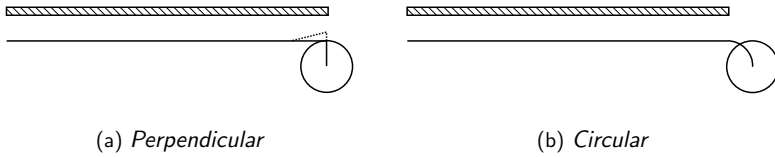

Figure 4.17: Careful run-up motions near part geometry can help to prevent overcutting.

Demands from workpiece thinness

Tool paths need to be generated in such a way that machining is done on account of maximal stiffness [Andringa 2001b].

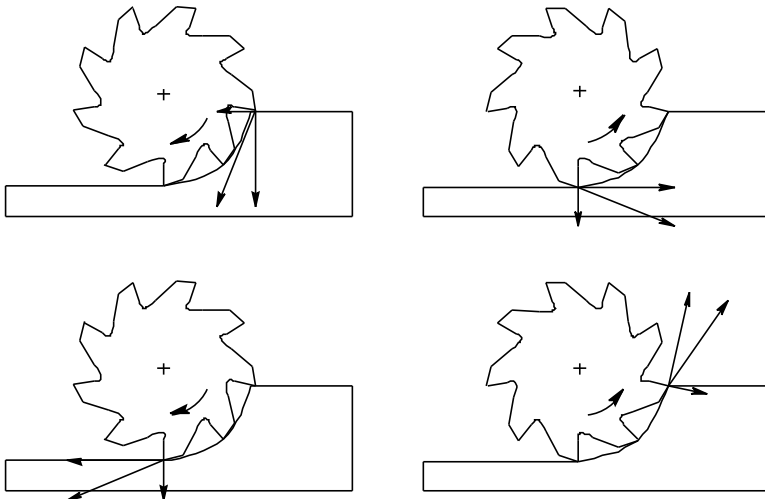

Figure 4.18: Forces in down milling (left) and up milling (right).

- When machining thin-walled product geometry, down milling (climb milling) needs to be used for sufficient surface quality, as already discussed in section 2.2.2. The resulting force direction is more constant in down milling than in up milling. Up milling has a force resultant alternately pushing and pulling the thin geometry, down milling has a constantly pushing resultant, as depicted in figure 4.18. Up milling will thus tend to cause workpiece vibrations.
- This down milling demand also applies when the end face of a mill machines thin geometry. This specific demand can for example be achieved by a helical strategy. For a zig-zag strategy, this requires one-way paths.

- A full cut must be prevented to occur at a pass adjacent to thin-walled geometry. The increased forces and risks of vibrations pose too much risk of exceeding the accuracy of the thin geometry.
- Moreover, depth of cut and/or width of cut (stepover) need to be adjusted when machining thin-walled geometry, to reduce both cutting forces that act on the wall as well as the chance of vibration. The thin workpiece is the weak element. Looking at figure 4.18, one can see that a low stepover will also make that the resulting cutting force will be more directed towards material, i.e. more in the length direction of the wall, and thus will have less deflection as a result. Naturally, depths and widths of cut should not be reduced so far that rubbing occurs between tool and workpiece, or that the low immersion becomes a cause of vibration.
- Careful run-up motions, both axial and radial, are also preferred from a stiffness point of view. Again, the cutting load will be more directed towards material (towards the length direction of the wall), thus reducing the risk of inaccuracies.
- As remachining of thin workpiece material must be avoided, scallops should be prevented, both on bottom and sides of an operation. In other words, separate finishing passes to remove scallops must be avoided, tool paths should remove all material in one go. Both motion strategies and stepover reduction can be means for this.
- Top-down machining of thin geometry is highly preferable. The tool path sequence within a machining feature should be related to the step approach.

As can be seen, these demands are mostly related to the finishing conditions that are needed when machining thin-walled geometry. These can best be considered as general finishing conditions; they should not just be applied on workpiece geometry that is already thin. Namely, when machining the first side of a wall, the workpiece geometry is not yet thin. If nevertheless finishing conditions for thin geometry are applied, the two sides of the wall will be machined (finished) more similarly. Resulting internal stresses will tend to be more in equilibrium than when differing conditions are used, so the chance of product warping will be less.

Optimisation issues

- Non-cutting motions within an operation, like rapid and retracting motions, need to be minimised (see also section 1.3).

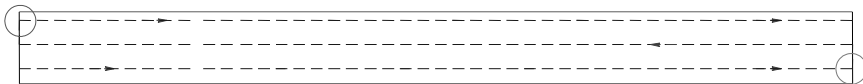

Figure 4.19: Example tool path for a moderately long machining feature.

For walls, machining features often occur that are generally relatively long when compared to other sizes, see figure 4.19. Rapid motions can occur on each z-level for the operation of such a feature. In the worst case, the tool has to travel along the length of the feature each time. The more this occurs, the less one benefits from the speed gained by using high-speed machining. Optimising tool paths to minimise such rapid movements will yield a profit, as such situations can occur quite often. It is to be expected that there is more to gain there than in rapid motions between operations. First, the sequence of operations is relatively fixed due to feature sequence constraints. Thus, reordering of operations, a common optimisation approach, will have only limited effect because there is only limited room to vary. Second, there are more changes (motions) between z-levels than between operations.

4.3.3 Demand consequences

Generally speaking, zigzag-type patterns are preferred over helical ones when thin-walled geometry is involved. Some reasons are provided by Andringa [Andringa 2001b] and Hagen [Hagen 2004]:

- Top-down end-milling of thin geometry is easier to achieve using a zigzag motion than when using a helical motion.
- Zigzag tool paths generally generate longer straight cuts than helical paths.
- Helical patterns are more likely to introduce full-cutting passes when they are not strictly necessary.

The demands that affect the tool path pattern appearance the most are those concerning the type of finishing pass (down milling, no full cut) and minimisation of rapid motions.

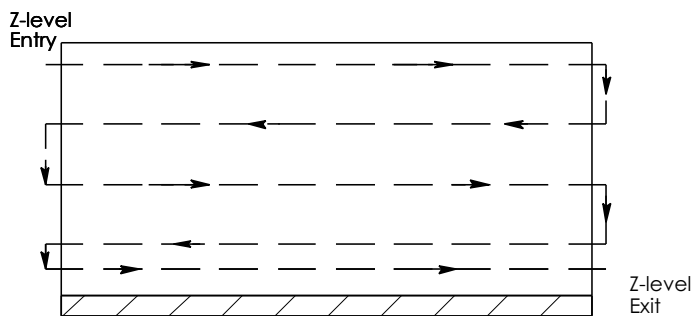

Figure 4.20: Tool path with adapted finishing stepover when machining thin geometry.

Figure 4.20 shows a typical example of a desired tool path pattern for a thin-walled product. The bottom of this operation - or perhaps even of just this depth step - is not

adjacent to product material, but bulk material. One side of the volume is adjacent to thin product geometry, the other sides are open. The pass machining the thin geometry must have the appropriate finishing conditions: down milling and a low stepover. This is not necessary for the other passes, so there, more efficient (roughing) conditions can be applied.

Such considerations also hold in the axial direction of the operation. If the bottom of an operation machines thin product geometry, only the last depth step (axial pass) of the operation requires adapted thin geometry finishing conditions. This can thus cause this z-level pattern to differ from the other z-levels if restricting conditions are only applied where needed.



Figure 4.21: Another example tool path for a moderately long machining feature.

Figure 4.21 shows a moderately long machining feature with a zigzag tool path pattern using an even number of sidepasses. The figure shows that the tool path entry and exit are on the same side of the feature. This is relatively efficient.

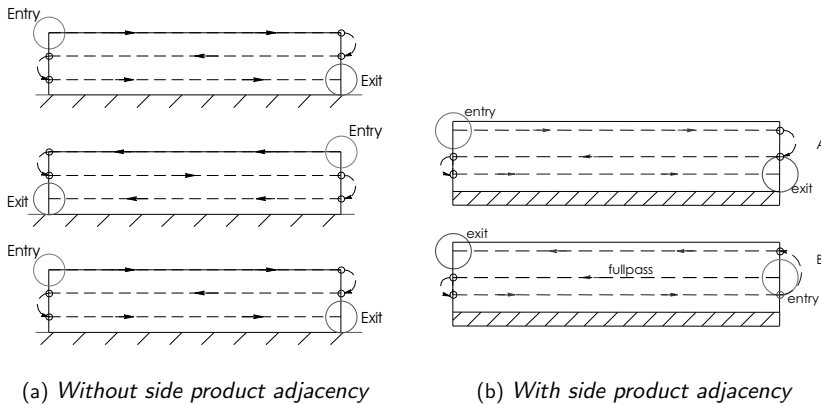

Figure 4.22: Possible subsequent depth steps for operation volume that require an uneven number of sidepasses; after [Andringa 2001b]

Figure 4.22 shows other examples of tool paths satisfying the demands from section 4.3.2. Typically, patterns in the figure change for subsequent depth steps (z-levels) for efficiency reasons. For this case, reversing the pattern (not shown) is the option that results in minimum rapid motion between z-levels. However, reversing the pattern can contradict top-down machining. Figure 4.22(a) shows patterns for subsequent depth

steps where the path is mirrored instead of reversed. This can be combined with top-down machining, and is still relatively efficient because the path entry of a depth step is on the same side of the volume as the path exit of the preceding depth step.

In case the side of the operation volume is adjacent to thin product geometry, the path of figure 4.22(a) does not suffice, because one of the z-levels employs up milling at the material adjacent pass. To achieve down milling in a case like this, there are three options. The first is to create a pattern with an uneven number of sidepasses, with a down milling finishing pass, and to use that for each depth step. The unefficient rapid motion is tolerated. The second is to create a pattern with an even number of sidepasses (using a smaller stepover), with a down milling finishing pass, and to use that for each depth step. The rapid motion will be reduced because the entry and exit for a z-level are on the same side of the volume, but the path itself is longer. The third option is to use alternating depth steps as depicted in figure 4.22(b). Down milling is used, with an uneven number of sidepasses by enforcing a full cut in one of the two depth steps. The rapid motion will be reduced because the entry and exit for subsequent z-levels are on the same side of the volume. The path for a single depth step is approximately the same length. However, the full cut requires a smaller depth of cut for the whole depth step. This can cause the number of depth steps (axial passes) to increase, and with that the total tool path length. Which one of these options is the most efficient can differ for different cases. This is even more so because the different patterns can induce different speeds and feed rates to be used, and tooling can be restricting there.

4.3.4 Modular tool paths

In essence, rather specific control over tool paths is needed. Restricting cutting conditions, like reduced width or depth of cut, for finishing or due to a full cut, are preferably only applied where needed, as locally as possible. Such efficiency allows for better utilisation of the capabilities of high-speed milling.

Such specific control can be achieved when operations are split up into regions, in which these different conditions are applied. This concept will be referred to as the modular operations concept, and was set up and worked out together with Andringa [Andringa 2001b] and Hagen [Hagen 2004]. Within a z-level, three regions can be distinguished:

Boundary volume: with thin geometry finishing conditions: down milling, low stepover, possibly limited depth of cut and appropriate feed and speed

Full cut volume: with appropriate conditions: limited depth of cut (which affects the whole z-level), width of cut equal to the tool diameter, and appropriate feed and speed

Rest volume: with the most efficient conditions, i.e. roughing conditions

Figure 4.23 depicts the idea of how tool path regions can be arranged for a single depth step for a free-shaped 2.5 dimensional volume. As noted in the previous section,

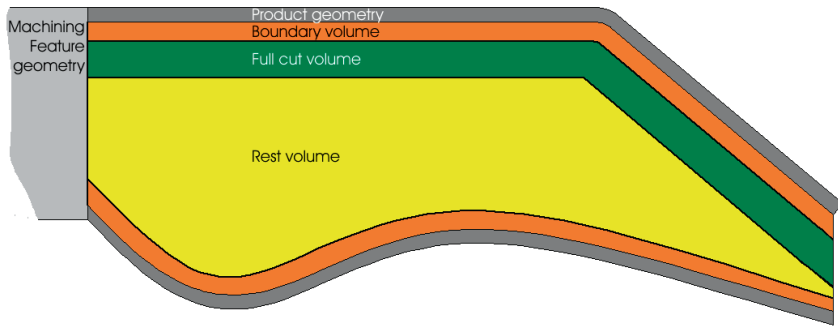

Figure 4.23: Example tool path volume distribution for a single z-level, after [Andringa 2001b].

thin geometry and/or efficiency demands can result in different depth steps within an operation. This is even more so when restricting conditions are applied as locally as possible. Figure 4.24 shows a three-dimensional view of an operation where this is the case. The figure shows three kinds of z-levels, in which the different regions can be distinguished. In the figure, the reduced depths of cut are visible, that are needed for end milling thin geometry in the last depth step, and for employing a full cut, respectively. If the last depth step is adjacent to thin product geometry, the associated finishing conditions must be applied in the whole depth step; down milling and reduced cuts are required in all of the layer.

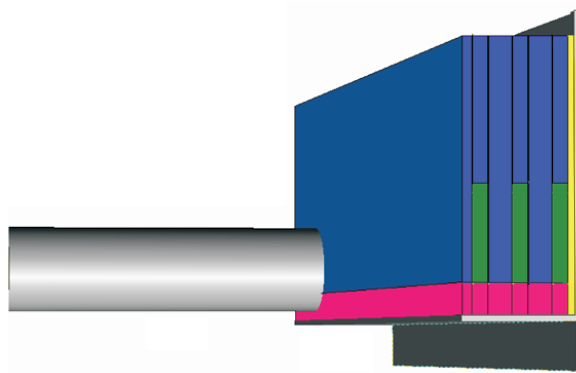

Figure 4.24: Example tool path volume distribution for an operation, after [Andringa 2001b].

4.3.5 Region subdivision criteria

The tool paths and region divisions discussed in previous sections represent ideal cases. How to achieve such modular operations is a design question and will be discussed in the next chapter. Another question is when which specific regions are necessary and with which specific conditions they need to be applied.

Whether a boundary volume is needed, for example, depends on whether the side of the operation volume is (partially) adjacent to thin product geometry. Whether the last depth step requires adapted cutting conditions depends on whether the bottom of the operation volume is (partially) adjacent to thin product geometry. As stated before, these adjacency characteristics can be generalised from 'adjacent to thin product geometry' to 'adjacent to product geometry', so that more similar machining is performed on the different sides of a wall. If an operation volume is not adjacent to product geometry, any favourable tool path strategy can be chosen. In that case, there is no need for down milling, reduced cut, careful run-up motions or scallop prevention from a stiffness point of view.

If an operation volume is adjacent to product geometry, the shape and size of the adapted regions (volumes) depend on the shape and size of the operation volume, the exact product adjacency situation of the volume, the tool used and values used for depth of cut and stepover for the regions.

The same is valid for the region division coming from efficiency considerations. What is most efficient depends on the situation at hand: shape, size and product adjacency of the operation volume and the tool and cutting conditions used. For example, in case an uneven number of passes occurs, z-level entries and exits can still be relatively close to each other due to the shape of the volume. A full cut volume may not be the most efficient solution then, and neither may be having different paths per depth step.

Chapter 5

Application design

The preceding chapters have pointed out which are the important tasks in computer aided process planning for this application domain, as well as the strategy-related knowledge to be used during these tasks. In this chapter, this is detailed into a design for computer aided process planning software for the application domain. The first two sections provide a very general overview in the sense that they discuss the general workflow and the reference data structure for the software. Following, section 5.3 discusses the design of the strategy-based tasks; the core functionality that will be responsible for applying knowledge as described in chapter 4. Section 5.4 discusses additional tasks that are important to come to an end result in terms of a proper process plan.

Due to the organisation of the project, the application base of the software was known on beforehand, namely Tecnomatix' machining process planning software *eMPOWER Advanced Machining*. This software incorporates functionality as described in sections 1.4 and 2.3.5. It provides a good basis and allows to focus on the new aspects and concepts of the application domain. Being a given, it consequently influences design in terms of data structures, functional architecture and user interface.

5.1 Envisioned process planning workflow

The workflow discussed here is a general one, based upon the company situation at Fokker Aerostructures. This workflow has been the basis of the design and implementation of the process planning software. Some variation is possible within the workflow, but the general order of the steps is as described. As it is based upon a single company's practice, several presumptions are made:

- The whole product is assumed to be thin-walled.
- The product is machined in a single setup.
- The machine and tool set to use are known on beforehand.

The following steps form the envisioned general workflow:

Stiffness feature determination: The stiffness features of which a part consists must be determined in order to deal with the stiffness issues that they entail.

Determination of set-up and resource sets: The setup of a product needs to be determined in an early stage. Top-down manufacturing is envisioned, and the set-up is determinative for what is up or down for the workpiece. It thus influences how the part must be interpreted. As some knowledge-based steps also reason with manufacturing capabilities of resources, the machine and cutting tool set also must be known relatively early.

Connection determination: As appeared in chapter 4, physical connections between stiffness features can play an important role in knowledge-based process planning steps. Manufacturing decisions for stiffness features often depend for a part upon connected features. This connection data must thus be available for these knowledge-based steps.

Stiffness feature sequencing: This is knowledge-based determination of sequence relations between stiffness features, which are in fact sequence relations between the machining feature groups for these stiffness features. It can be seen as product level sequencing based upon user-defined stiffness-based manufacturing knowledge. Section 4.2 discussed this kind of knowledge.

Machining feature determination: This concerns knowledge-based determination of machining features and their sequence for manufacturing (combinations of) stiffness features. It can also be seen as a form of manufacturing method selection for stiffness features, based upon user-defined stiffness-based manufacturing knowledge. Section 4.1 discussed this kind of knowledge.

Automatic and interactive machining feature modification: Knowledge-based machining feature determination may not give a complete solution in terms of machining features, because it most often reasons about stiffness and manufacturing of a subset of all stiffness features. Resulting machining features may overlap each other, be arranged impractically, or not cover the geometric difference between part and blank. Tools are needed to resolve this.

Automatic and interactive feature sequence relation reviewing: Also knowledge-based determined feature sequence relations may not give a complete result, similarly as for machining feature geometry. Machining features may block each other's machining (tool access) directions, which can call for application of additional sequence constraints, or removal of conflicting ones. Changing sequence relations to improve the process plan must thus also be possible.

Selection of machining methods and tools: Knowledge-based selection of operation methods, settings and tools for the machining features, based upon user-defined technical and economical knowledge. Machining feature adjacency to thin-walled product geometry can play a role in method selection.



Calculation of tool paths and cutting conditions: This task concerns working out the chosen methods for the machining features into fully detailed operations in terms of tool paths and cutting conditions. When operations machine thin-walled product geometry, paths and conditions will be calculated accordingly.

Determination of machining sequences: The workpiece's time on the machine can be optimised by minimising non-machining time between operations. To this end, operation sequencing must minimise the number of tool changes and the overall tool travelling times [Erve 1988], whilst considering all sequence constraints.

5.2 Reference data structure

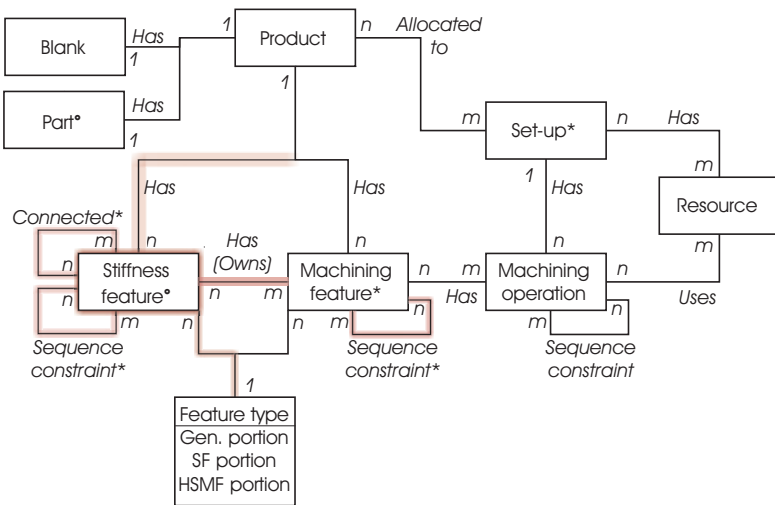

Figure 5.1: Reference data structure.

Figure 5.1 shows the reference data structure, which reflects the application domain specific variations upon the Tecnomatix machining process planning software data structure. The data structure of the application base is summarised in the portion without shadowed lines. A set-up, for example, has a set of operations. These operations use resources (machine tools, cutting tools et cetera) which the set-up has at its disposal. One or more machining features can be machined by one or more operations. The exact form of some relations is different; the figure shows a simplified view.

The shaded elements in figure 5.1 represent the extensions from the application domain under research. They are the elements introduced in the previous two chapters. These are stiffness features of a product, physical connections between them, sequence relations between features and the relation between stiffness features and machining features, which indicates which machining features 'create' a stiffness feature when

machined. Stiffness features and machining features can for a part make use of a shared set of feature types. This can require extensions of these types with stiffness feature specific and HSM machining feature specific data. Besides the added elements, the context needs discussion. A Part will now be considered in the process planning in terms of stiffness features instead of machining features, an association (context) indicated by the \circ symbol in figure 5.1. Furthermore, many process planning data is determined in the context of a set-up. The placement (orientation) of a product in the set-up is determinative for the manufacturing approach to choose. In figure 5.1, the * symbol indicates this association introduced by the application area. The set-up context plays a part in determination of connections, machining features and feature sequence constraints, which together determine how stiffness features are manufactured.

5.3 Design of strategy-based tasks

As noted in section 3.2.5, and elaborated upon in chapter 4, strategy-based tasks based on knowledge-based reasoning form a core part of process planning for thin-walled parts. The following subsections discuss how demands from the knowledge, as described for the different levels chapter 4, are translated into design for subtasks in computer aided process planning software.

5.3.1 Machining feature determination

It has been noted in earlier chapters that the sets of machining features plus their sequence constraints can be considered as manufacturing approaches for stiffness features. Determination of these machining features and sequence constraints is also similar to determination of machining operations for features. They both concern knowledge-based decisions and application of manufacturing knowledge upon features. As part of the Tecnomatix machining process planning software, automatic method selection functionality as described in section 2.3.5 forms part of the application base. Although the knowledge for a stiffness method - see figure 4.12 - looks a lot more complex than for a machining method - see figure 2.16(a) - reasoning inside and outside the knowledge is very similar to that in the method selection technique. Machining feature determination is therefore based on the same mechanism. Table 5.1 shows similarities of the two applications, and table 5.2 list differences between them, that need to be overcome to support the new application.

Basing machining feature determination on method selection has several advantages:

- Software modules are available for applying knowledge on one hand and editing the knowledge to use on the other hand.
- Because method selection is also available for operation determination, editing of manufacturing knowledge will be similar for a knowledge engineer.

Similarities
The result is application of manufacturing approaches to the given features.
Knowledge rules can have features as input as well as output, possibly multiple features per rule.
Knowledge is often much related to geometric properties of the given features.
Reasoning is based upon the final situation. Reasoning backwards from there to determine the appropriate manufacturing approach to achieve it is a sensible approach for both applications.
Information about the workpiece material is relevant and therefore part of the input.
Data about (preferred) tooling to be used for manufacturing the features can be used in the knowledge.
The order in which rules are applied on the input must be steerable (through priorities).

Table 5.1: Similarities of operation method selection as described by [Houten 1991], available in *eMPower Machining*, and the envisioned machining feature determination.

- Using a proven knowledge reasoning mechanism allows for focussing upon other aspects of the problem area.

Reasoning for machining feature determination is generally more complex, uses larger input data sets for its decisions and is based upon substeps that can generate and take in intermediate data (see section 4.1.4). The main differences concern the input and output data and how they are structured. Especially relations are expressed differently. Relations are expressed more explicitly between features in the input and set more explicitly by the knowledge in the output. Also, the unknown quantity of input and/or output features presents an issue that must be addressed.

These issues can be taken on in two ways. One is to pre-process input data and post-process output data so that existing software can be reused as-is (pre- and post-processing convert the data). The other is to adapt the software so that the reasoning can work directly upon the data in its original form. The second option is more preferable, if only because it makes knowledge definition more straightforward. Due to time restrictions, however, the first option has been chosen in practice.

5.3.2 Stiffness feature sequence constraint determination

Summarising section 4.2.3, stiffness feature sequence constraints can be determined by applying rules of the following form. If two particular features (primary input) comply with certain conditions, a sequence relation (output) is to be applied between them. The conditions can generally concern material aspects, connected features or setup-related information (secondary input) besides characteristics of the features themselves. Priority of the rules is important to prevent conflicts.

Differences	
Operation determination	Machining feature determination
The number of input and output features is fixed per knowledge rule.	The number of input features for a knowledge rule is often unknown, and so is the number of output features.
The main results are the operations and their cutting parameters, tools and sequence constraints.	The main result are the machining features and their sequence constraints.
Intermediate data is generally not used. If it is, it is expressed in terms of features. Data between rules usually represent physical intermediate states.	A form of intermediate data is needed. Its representation must be such that it is able to convey the proper information from one rule to the other.
Conditions involving cutting tool data are either aimed at selecting the cutting tool to be used for machining, by imposing restrictions, or at determining output data based upon the finally selected tool.	Conditions involving cutting tool data generally do not restrict the cutting tool to be used for machining, but determine output data based on a preferred tool.
Relation data concerning physical contact between input features and sequence constraints between them are represented as a single type of relation.	Relation data concerning physical connections between input features and sequence constraints between them are represented as separate relation types.
Output sequence constraints are between operations.	Output sequence constraints are between features.
Output sequence constraints are implicit in the knowledge. The software deduces them from the application sequence of the rules, through the resulting operation structure.	Output sequence constraints must be created explicitly by the knowledge rules.
Rules most often represent an autonomous manufacturing approach (machining method) for the input features.	Rules most often represent part of the reasoning to apply a manufacturing approach for the input features.

Table 5.2: Differences between operation method selection as described by [Houten 1991], available in *eMPower Machining*, and the envisioned machining feature determination.

Again, there are similarities in the knowledge and functionality with method selection and with machining feature determination. Similarities with machining feature determination are more evident: connections and relative positions are important, and machining feature determination can also require rules with a sequence constraint as sole output, i.e. between existing machining features. The knowledge complexity is less when compared to machining feature determination.

An essential issue for stiffness feature sequence constraint determination is the priority

of the used rules. In case of possible inconsistency, the sequence constraint should prevail that was determined by the rule with the highest priority. These conflicting constraints may be between entirely different feature pairs (i.e. different input). In method selection, rule priority is mainly used to determine in which order rules should be tried upon the subset of the provided input that that it is working on, which can be a single feature.

As rule priorities concern the total input of stiffness feature sequencing determination, instead of a subset of the input as is the case for method selection, it has been chosen to use an other similar rule-based approach. In addition to processing the rule knowledge in order of priority for the total input instead of a subset, which is the main variance, a validity check is needed before an applicable rule is enforced. This must check on potential conflicts with existing sequence constraints, from previously applied rules (with higher priority). If this validation fails, the rule is not applied, and other rules that may be applicable to the same feature pair can be tried in a later stage.

5.3.3 Machining operation computation

This section discusses the design for calculation of operations for machining features, including tool path generation and determining cutting conditions. The section consists of three parts. First, the existing architecture of the application base concerning operation computation is explained. Next, options for realising the modular operations described in section 4.3 are explored. Last, the chosen option and the related task division is discussed in more detail.

Architecture

Section 2.3.5 introduced method selection as means for operation determination. As part of the Tecnomatix machining process planning software, automatic method selection functionality forms part of the application base. Method selection is however just the first step of computing operations. It is aimed at selecting the best manufacturing methods for input features, given the available resources, and to create operations with attributes that satisfy the demands of the methods. Which these demands are and to which extent the operation attributes have been set depends mostly on choices of the knowledge engineers. Automatic completion of an operation's computation requires calculation of tool paths and unknown cutting condition attributes based upon the known attributes. For this completion, the Tecnomatix software offers the following essential functionality, partially based on the work of [Boogert 1994]:

- tool path calculation algorithms.
- calculation of two-dimensional boundaries, which tool path calculation algorithms need as input to determine the actual trajectory; they can be derived automatically from the feature volumes to machine.

- calculation of unknown cutting conditions, based upon a model of the machining process and the available resources.
- calculation of non-cutting motions.

This functionality is offered in a modular architecture. It supports automation of the completion, its modules can be changed, and it supports calling external tool path pattern algorithms. Especially the flexibility with respect to possible changes is beneficial. The architecture allows for different calculation submodules to be used for different operation types. The architecture is depicted in figure 5.2 in a simplified way. The calculation submodules responsible for working out the operations into detail will also be referred to as generators.

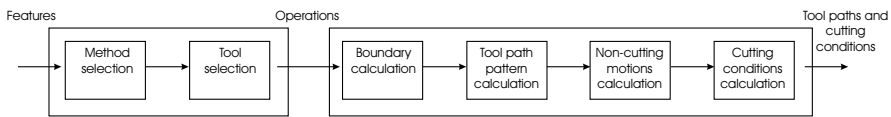

Figure 5.2: Simplified view of the architecture used for operation computation.

As Boogert remarks, tool path pattern algorithms have to be controlled by among other things a stepover distance. This means that the width of cut is laid down; the two-dimensional engagement of the cutter can be determined from the stepover and the tool path elements. For milling, this leaves the following operation parameters to be determined by cutting conditions calculation: the depth of cut (a_p), the feed per tooth (f_z) and the cutting speed (v_c). [Boogert 1994]

Modular operations

In section 4.3, the modular operation concept was introduced: outline different regions within an operation, and generate paths with cutting characteristics specific for each region. Several types of regions were discerned: boundary regions, full cut regions and rest regions, which properties can differ depending on the adjacency of the operation layer. There are three conceivable mechanisms for creating these regions within the operation.

Modular methods: Through method knowledge, split up the volume into sub-volumes, one for each region, and apply separate methods for each sub-volume. Tool paths are generated for each sub-operation and united into one operation afterwards.

Modular tool path generator: Apply a single method for the whole volume. During generation of the tool paths, split up the operation into sub-operations and generate paths and conditions for each one. In other words, execute the needed tool path generation chain for each sub-operation; see also figure 5.3.

Modular pattern algorithm: Apply a single method for the whole volume. The tool path generation chain is executed once for the entire operation. The actual tool path pattern calculation algorithm - executed for the operation volume as a whole - is responsible for applying the proper patterns and conditions in the right regions.

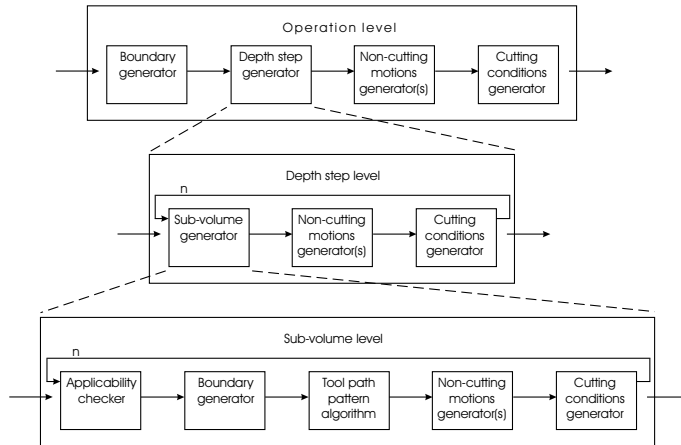

Figure 5.3: The idea of the modular generator structure. This is a modified version of the structure design by Andringa [Andringa 2001b].

Whether different regions are needed and which, is in the first place determined by the possible adjacency of the operation volume to product geometry. This adjacency must thus be explicitly available to the mechanism that creates the regions.

Method selection is knowledge-based, not geometry-based. It cannot analyse the adjacency of the volume at run-time, so the exact adjacency must be expressed explicitly for a machining feature, e.g. as a parameter. When using modular methods, all possible volume distributions need to be defined in the knowledge, and thus need to be determined on beforehand, for each type of feature. Many methods are needed, making method knowledge definition and maintenance laborious. For a rectangular pocket, for example, at least 12 different adjacency situations can be distinguished. In addition, a large set of sub-operations can result for a single operation. In combination with the large number of operations that are generally needed for thin-walled products, this will complicate the data and reduce overview for a user. User editing of the result will also be more difficult, as certain edits can require the sub-operation volumes to change. Size changes, but even changes of volume configurations can be in order. Such changes are difficult to propagate when these dependencies are only laid down in method knowledge.

The modular tool path generator approach (figure 5.3) does not bear the disadvantage of the large amount of knowledge methods needing to be defined for different configurations. The exact product adjacency of the feature can be determined from the geometry situation; in the generator structure, the boundary generator is typically

responsible for analysing the geometric aspects of a feature. This generator can thus be extended to take the responsibility for determining which regions may be needed, based upon geometric reasoning. In other words, based upon product adjacent faces of the feature, and using offsets based upon stepover distances, a worst-case volume distribution can be determined: the maximum set of sub-volumes that an operation z-level may consist of. Sub-generators are responsible for determining the boundary for each sub-volume and appropriately applying a pattern algorithm. The first step for the next region is determining the remaining volume in the z-level and whether the region is actually needed. If not, its calculation is skipped. Per sub-volume, cutting condition calculations can be used to determine a depth of cut. The cutting condition generator on depth step level is then responsible for determining which of the depth of cut values for the sub-volumes in a depth step is the most restrictive one, and for using it. As different depth steps (layers) may be needed, calculation of these layers can be called repetitively as often as needed.

In this approach, an operation still consists of sub-operations in the sense that tool path patterns are generated for each sub-volume separately. A user however not necessarily has to be confronted with these sub-operations. But besides the internal data, the tool path module also becomes more complex.

A partial alternative for this approach is to use method selection for some basic decisions and thus move some responsibility away from the tool path module. Based upon general adjacency data and a feature's type and sizes, method knowledge can determine which regions may be needed in the worst case, and with which operation parameters.

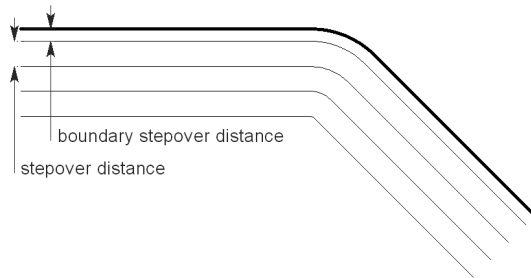

Figure 5.4: General idea of the modular pattern algorithm.

Finally, there is the modular pattern algorithm approach, which uses a single tool path pattern algorithm for the operation volume. Based upon boundary input plus stepover distances, tool path passes in the operation volume can be offset at the right distances from product adjacent geometry, as the example in figure 5.4 shows. The exact product adjacency of the volume is best determined from the geometry in the boundary generator, and incorporated in the boundary data, before calling the pattern algorithm. As a single algorithm is used, a single operation results, rather than a set of sub-operations. Furthermore, the functionality for the region handling is concentrated locally, requiring only limited adaptation of the remainder of the tool path calculation

module. Different types of operations, like profiling or pocketing, can however require different pattern algorithms capable of generating modular tool paths. Furthermore, the determination of the depth of cut presents an issue in this approach. If the algorithm calculates all different z-level layers together, the depth of cut must be determined on beforehand and provided as input to the algorithm. Only if calculated z-level tool path layers are stored separately, the depth of cut can be determined based upon cutting conditions, and layers can be accordingly copied as often as needed.

The method-based approach is not chosen because it requires too laborious definition and maintenance of knowledge to achieve the desired results. Both the generator-based approach and the algorithm-based approach are more generic in this sense. Of these two, the algorithm-based approach is chosen, because it localises the needed adaptations and with that the added complexity. It does require adaptation of the boundary generator, and special attention for the handling of different tool path layers.

Task division

The next passages will discuss the task division for generating the modular tool paths. They describe the revised responsibilities of submodules of the architecture described earlier in this section (see also figure 5.2).

Method selection

It is chosen to let method selection decide about a worst case region subdivision, and with which parameters these regions should be applied. Based on general adjacency data, method selection can determine whether boundary regions are needed at all. Bottom face product adjacency forms an exception. As 2.5-dimensional volumes are considered - which have a single bottom face - bottom face adjacency is assumed to be known exactly during method selection. In other words, it will be determined entirely through knowledge whether a layer with bottom product adjacency conditions needs to be applied. Furthermore, a full cut volume can be needed because a feature type has a closed boundary - a pocket, for example - and such type-based decisions are a strength of knowledge-based reasoning. Also, full cuts can be useful for efficiency reasons. In knowledge, it can be expressed under which conditions a full cut should be applied for efficiency, based upon among other things parameters of the feature and candidate values of the stepover. If a particular size of a feature is small, for example, using a full cut to prevent rapid motions may have little effect or even be inefficient. As the exact adjacency situation will not be available in the knowledge, such efficiency choices will be educated guesses.

Tool path pattern calculation

A modular pattern algorithm will provide the options that are needed to create the regions with the proper parameters. It must provide handles to give in data that will result in the proper tool paths. These are the application area-specific demands for such an algorithm:

- be able to use ramping axial motions for closed contour volumes

- be able to use a smooth (circular or tangential) run-up to a pass adjacent to product geometry
- preferably be able to round sharp corners in general
- be able to apply different depth steps, depending upon the input settings
- be able to enforce full cuts, depending upon the input settings; this must be adjustable per different layer
- use a reduced depth of cut in layers where a full cut is used
- use down milling and a reduced stepover at product adjacent boundaries
- use down milling, a reduced depth and/or width of cut in product adjacent bottom layers
- a zigzag type motion pattern is preferred.
- the motion pattern must aid in the prevention of scallops

Boundary calculation

The boundary generator remains responsible for calculation of the boundaries that the tool path calculation algorithms need as input to determine the pattern trajectory. The existing generator uses solid modelling intersection techniques, which allows for using the actual geometric situation. Additional information is however needed for modular tool path pattern algorithms, so this puts additional demands upon boundary determination. First, the exact boundary elements need to be known that are adjacent to product geometry, because they require a boundary region in the tool paths. Second, the full profile of the volume needs to be determined. In traditional CAM, not all pattern algorithms require the boundary profile to be closed. Examples are found in patterns for profiling paths. In order to prevent machining of product geometry that is already thin, however, it must be assured that tool paths do not exceed the operation volume boundaries too excessively, which requires the full boundary to be known. Figure 5.5 depicts this context difference (the whole product of figure 5.5(c) is thin-walled). Finally, a distinction should be made between the boundary elements that are not product adjacent: these are either open or adjacent to other machining features that are not yet machined. Boundary elements adjacent to other machining features are allowed to be slightly exceeded, e.g. up to a distance of half the tool diameter. But only open boundary elements should be used for e.g. an entry into the layer.

Cutting conditions determination

The cutting conditions generator for milling in the Tecnomatix software is based on the work of [Boogert 1994]. The cutting technology model is based on submodels for cutting forces, surface roughness, tool life, consumed power and cutting data (cutting force experiments). One of the limitations on cutting forces is determined by tool deflection; this deflection should not exceed the tolerances specified on the workpiece.

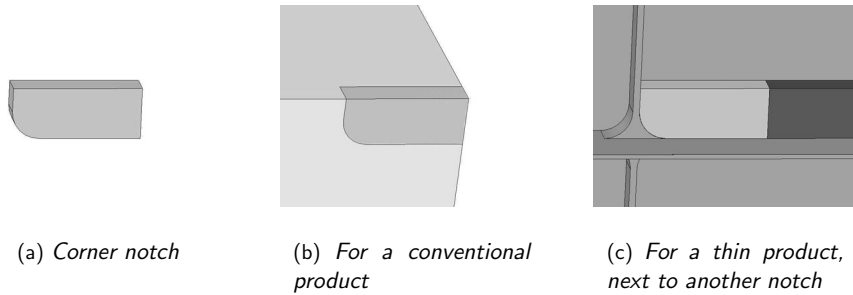

Figure 5.5: The different context of volumes for thin products, when compared to conventional products, puts different demands upon boundary generation.

As noted earlier in this section, cutting condition determination is responsible for determining remaining unknown parameters; feed rate, cutting speed and possibly axial depth of cut. Depth of cut, being a geometric cutting condition, plays an important role in the final region subdivision of a modular operation tool path, as discussed before. Applying finishing conditions locally in modular operations also implies that finishing feed rates and speeds are applied during finishing path segments only. This is similar to the circular feed factor option that operations can have defined in the Tecnomatix software. If enabled, the cutting conditions generator calculates the feed reduction that is necessary on circular path segments - i.e. in corners, due to increased cutting load and thus force - and attaches the result to the path segment. It is also possible in the software to manually edit feed rates and speeds for individual path segments. Such an approach is also possible to make the feed rates and/or speeds more local. If the finishing tool path segments are properly labelled with the necessary information, the software could determine and attach the proper cutting conditions for these segments and apply roughing conditions for the other segments.

The existing technology model is insufficient for thin-walled parts, because it should also take the flexible workpiece into consideration. For thin-walled products, it is at least desired that cutting forces do not cause wall deflections to exceed tolerances. Even more desirable is avoidance of vibration problems. The step approach reduces scope of the thinness, which can justify simplifications in reasoning about thin geometry. Depth of cut should primarily be used to address bending, because in the end, vibrations problems can still be addressed by a machine operator by changing feed rate and/or spindle speed.

For bending, the flexible workpiece can be considered through an additional force constraint in this cutting model. Such a force calculation can be based on a model similar to that for machining feature sizing. Assuming that a machining feature is aware of its physical place relative to a stiffness feature, the restricting force can be calculated, and passed on to its operation(s).

Nevertheless, if the task for cutting conditions determination is also to make sure that dynamic instability does not become a problem, the only option is to resort to

empirical data, due to the lack of proper calculation models to predict the occurring phenomena for thin-walled workpieces.

If such empirical data is scarce, rules of thumb are a final fall-back. This especially concerns the depth of cut, which should be small enough to avoid bending inaccuracies and large enough to avoid vibrations (if the depth of cut is small, cutting is less stable, and, force variation is relatively large compared to the nominal force). Such rules of thumb, depending on their form (e.g. depth of cut/width of cut ratios), can however typically be domain knowledge that can be expressed and applied through operation method selection, not necessarily through cutting conditions calculation.

5.4 Design of supporting tasks

The envisioned process planning workflow from section 5.1 lists more tasks besides the strategy-based ones described in the previous section. This section will discuss the design of how the remainder of the process planning tasks will be supported in the process planning application.

5.4.1 Structural product data interpretation

The term structural product data refers to the data representing the product during process planning. As became apparent in chapter 4 and sections 5.3.1 and 5.3.2, a thin-walled product is assessed in process planning based upon its stiffness features and particularly the physical connections between them. Combined, they can be considered to represent a product's structure. The following subsections consider the determination of stiffness features and connections from a design model.

Stiffness feature recognition

Automatic feature recognition functionality based on work as described in [Houten 1991] and [Geelink 1996] is part of the Tecnomatix machining process planning software. This seems to be a good basis, but the technology must be able to handle the difficulties posed by the application field, meaning the types of features to be recognised.

Protrusion features - thin walls - occur often on the parts. As the parts mostly can be considered to be built up from these features, they will tend to interfere more often than machining features, which are usually depressions. Examples are shown in figures 5.6 and 5.7. In addition to these protrusion features, depression features need to be recognised, such as holes and cutouts. This causes 'intersection by definition'; many of these depression features are *in* the protrusion, which can disrupt or complicate the recognition of the protrusion itself. Other depression features can pose problems because they can represent another view upon the same geometry as protrusion features, as shown in figure 5.8 (possible double recognition). The example may seem trivial, but notches

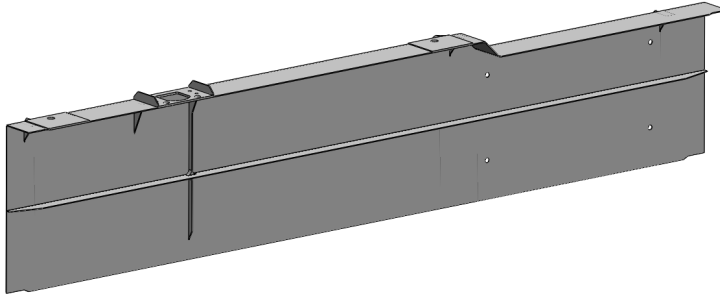

Figure 5.6: Examples of wall feature interferences on thin-walled products

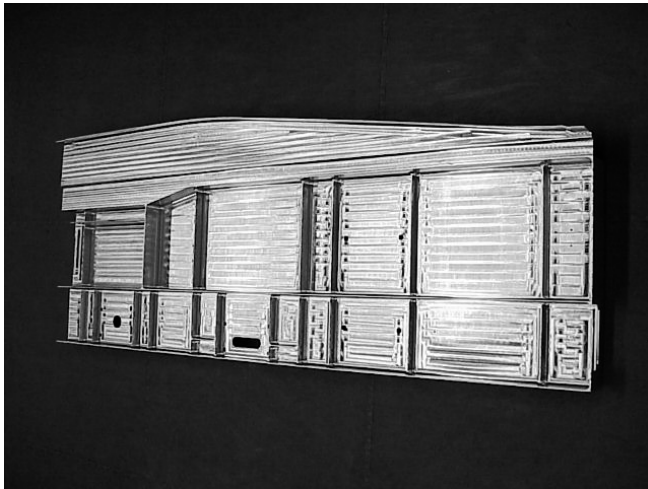

Figure 5.7: Examples of wall feature interferences on a thin-walled product

can also occur upon the top of walls, so it is desirable to recognise them. Recognition of a wall should thus generally take precedence over recognition of such depression features. So besides the ability to properly handle interferences, feature recognition should be configurable with respect to the types of features to be recognised or not and/or the relative recognition priority of these types (at least upon software development level). Finally, size (thickness) forms a criterion for thin wall features, as figure 5.9 shows. Stiffness feature recognition should consider these criteria.

The existing feature recognition module does provide the needed basis. Mechanisms and methodologies are available for dealing with feature interferences, as these formed a major research issue in the work of Geelink, and he recognises the influence of dimensions on a feature's meaning [Geelink 1996]. Furthermore, the module allows for explicitly including and excluding of feature types and setting recognition priorities for feature

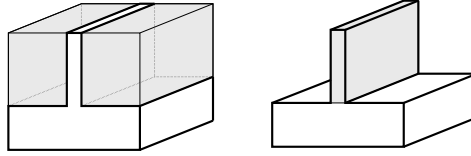

Figure 5.8: Different feature views upon the same geometry: side notches versus a wall

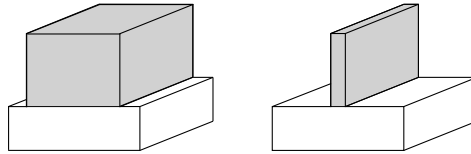

Figure 5.9: Whether geometry should be considered as a thin wall depends on size.

recognition (on user and system administration level, respectively). It allows for creating additional recognition algorithms for types not covered by the module itself through a programming interface. The recognition is face-based and uses pattern matching.

Connection determination

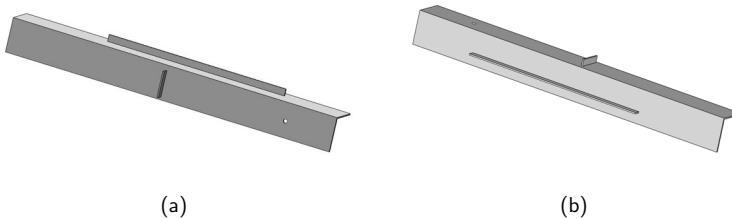

Figure 5.10: Whether a wall is 'on' another wall can depend upon the placement of a part in a setup

Connections, as a kind of relation, play an important role in the process planning process through knowledge. Especially whether stiffness features are on or in another (base-leaf connection) affects knowledge-based decisions. These relations can be determined mostly automatically based upon geometric reasoning. Due to their physical nature, they can be established by seeking interference, adjacency and/or geometrical connections like shared edges between geometrical representations of the stiffness features. Additional logic is needed to determine the type of connection involved, i.e. whether one feature for example forms a base of the other, or whether features cross. This logic coheres with certain assumptions about the data (feature types, connection structure and the set-up). A depression feature can for example never be the base of another feature, and whether a wall is 'on' another wall or vice versa can depend upon

the position and orientation of a product in a setup, as shown in figure 5.10. As up and down and thus base or leaf can vary depending on this placement, allocation and placement of a product and its stiffness features into a setup must be performed before automatic connection determination is carried out.

5.4.2 Modification of machining features

After knowledge-based machining feature determination, the resulting machining feature set may not be complete or appropriate for the given situation. This is similar to traditional process planning in the sense that the manufacturing knowledge set can never be complete. There can always be situations that the knowledge does not consider. Such situations can be handled by either updating the knowledge to incorporate them, or by manually editing the result. Several examples of different cases will be given in this section where additional work is needed to come to good machining features. Candidate functionality for performing this work, both automatic and interactive of nature, is discussed.

Dedicated machining feature recognition

Figure 5.11 shows why dedicated machining feature recognition is needed. Knowledge for the flange will most likely add feature A as a side-notch (figure 5.11(b)). However, if the machining features are considered of the wall that the flange is on, feature A appears to be a slot in reality (figure 5.11(c)). In fact, when a machining feature or its surrounding changes, recognition is needed to validate or redetermine the feature's type and parameters.

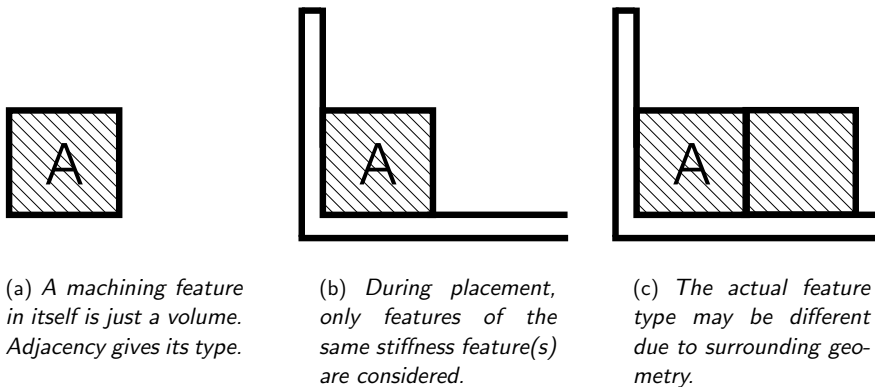

Figure 5.11: An example of the need for dedicated machining feature recognition.

This recognition is dedicated - different from common feature recognition - for the following reasons. The input geometry is the feature itself instead of a model that it

is in or on. The geometry must exactly match the feature definition, for reasons that will become clear later in this section; feature intersections are not involved. Finally, as figure 5.11 shows, the type of the feature also depends on its adjacency to geometry of the part or other machining features. Sequence relations between features also play a role. If the face of a machining feature is adjacent to another machining feature that must be removed before it, that face must be considered open. If that other feature was to be machined later, the face must be considered closed.

As the product adjacency of a machining feature plays an important role in operation computation for the feature (see section 5.3.3), analysis of this adjacency must be part of the recognition functionality.

Interference handling

The fact that knowledge-based machining feature determination cannot consider the whole environment of the features will also often result in machining feature volumes overlapping with other geometry. This geometry can be of the part or of other machining features. Such interferences are undesired, especially with part geometry, but also with other machining features. They could result in re-machining of part geometry which is already thin-walled, which can be disastrous. Furthermore, it can be plainly inefficient.

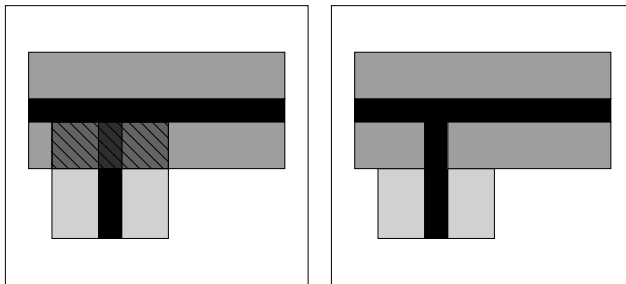

Figure 5.12: Example of interference handling. Black represents product, grey machining features and interferences are hatched.

Such interferences can be handled automatically, considering the subtasks. Overlapping geometry must be subtracted from a machining feature. In case of feature-feature interferences, a choice needs to be made which machining feature is more important and will therefore be subtracted from the other. This choice generally allocates the overlapping volume to the machining feature that requires most attention during machining, which can depend very much upon the associated stiffness feature. The choices can typically be based upon knowledge rules similar to those used for stiffness feature sequencing. Finally, the subtraction results must be analysed; resulting machining features must be recognised.

Machining feature splitting and merging

A third issue of the local application of machining feature determination knowledge is that the arrangement of machining features can locally be suboptimal, when looking at machining features of different stiffness features. Often, combining machining features locally will result in less and larger machining features, which is more efficient. In order to rearrange the features most efficiently, pre-arrangement by dividing features into smaller ones in compliance with the arrangement of adjacent features can be useful. (Such splitting can also be useful in for example interference handling. If a non-2.5D feature results, it can be split up into smaller ones to try to come to 2.5D features.)

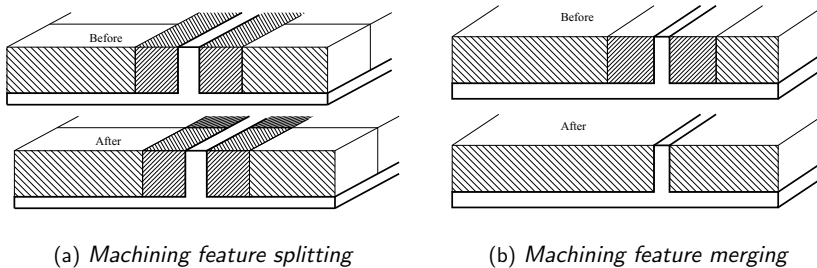

Figure 5.13: The idea of the machining feature rearrangement steps.

Figure 5.13 depicts the concepts of both splitting and merging of the machining feature geometry. The steps show some resemblance with the delta volume decomposition and cell composition steps of volume-based feature recognition based on cell decomposition. Combinations of features must qualify for this rearrangement. They must be adjacent, properly aligned and allowed to be machined simultaneously (i.e. no *before* sequence constraints between them). The rearrangement can be performed automatically or semi-automatically, but the noted demands can limit the possible results. Another drawback is that it is difficult to retain the results of applied knowledge, such as maximum or minimum sizes. Again, it can be necessary to do machining feature recognition on the resulting volumes.

Machining feature modelling

Another option to change machining features to better fit their environment and/or the process planner's wishes, is to provide forms of geometry modelling. With tools like sketching, a process planner can make features larger or smaller as desired. Such modelling tools can be offered as part of the CAPP software, or external software can be used, as long as the resulting geometry can be associated with the feature in the CAPP system. Again, a drawback is the difficulty to retain the results of applied knowledge.

Partitioning the remaining material

After knowledge-based determination of machining features, and even after the interactive or automatic modifications, the geometry of the part plus that of the machining features will rarely be equal to the blank. Figure 5.14 shows an example.

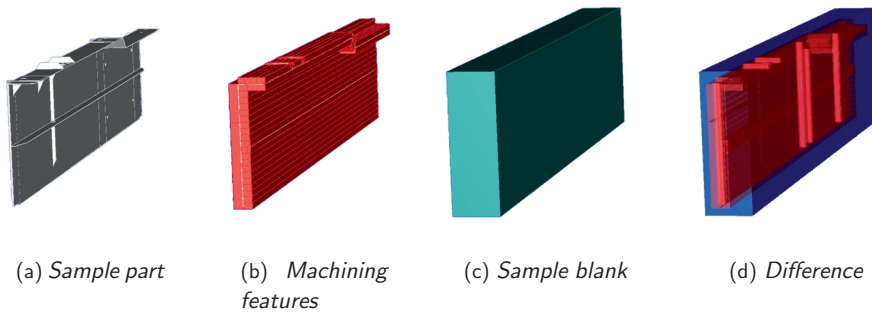

Figure 5.14: Example of remaining material

The geometric difference must be divided up into volumes to machine. An automatic approach is to automatically determine the geometry that remains to be machined and to subsequently perform a form of feature recognition upon this geometry to find the machining features.

Elaborated tasks

The available options for machining feature modification show overlap in the goals that they serve. In addition, their realisation is not trivial. Therefore, and because time restrictions and other priorities played a role, realisation is limited to a subset of them:

- **Dedicated machining feature recognition:** this functionality is needed or at least desired for all of the other forms of modification functionality.
- **Interference handling:** prevention of overlapping geometry is a high-priority goal, as overlap can give cause to remachining thin geometry. (Semi)automatic functionality for this prevention is considered necessary.
- **Machining feature modelling:** some form of interactively changing machining feature geometry is highly desirable. Otherwise, all such adaptations must be carried out on the level of operations. Direct modelling of machining feature geometry is preferred because it allows for the most user control over these changes.

Automatic machining feature splitting and merging was not selected for implementation. In essence, it serves the same goal as machining feature modelling. It does so

using a more intelligent approach, which is however also more complex and more restrictive in the results that can be achieved with it. A user is limited to the features that he/she is splitting and merging as building blocks. The two approaches also share the drawback that applied knowledge is not retained. There may be situations where a user may indeed want to exceed a maximum size, for example, because he thinks the automatic result is wrong. Interactive editing makes this a user responsibility, whereas from (semi)automatic changes, users will be less aware that applied knowledge may have been overridden.

Partitioning the remaining material is useful, but not strictly necessary. A user can create the necessary remaining machining features with the other available functionality, like machining feature modelling.

5.4.3 Sequence-related and accessibility-related tasks

Similar to modification of machining features, reviewing sequence relations is important, both on the level of features and operations. Accessibility can for example require additional sequence constraints. Accessibility can also concern collision avoidance, or reachability in the sense of machine kinematics or working depth. With these issues properly addressed, the system should try to find the optimal sequence within the limits set by sequence constraints from whatever source. The following paragraphs elaborate on these issues.

Reviewing sequence relations

Substep results in terms of sequence relations require special attention, due to the important role of sequence for the stiffness-based manufacturing approaches. As is the case for machining feature determination, the result of automatic determination of sequence constraints can be incomplete or incorrect for the situation at hand in the eyes of a process planner. A user must therefore be enabled to check and add, remove or change such sequence constraints. This holds for constraints on feature level as well as on operation level. Especially for checking the constraints, visual feedback to the user is important, if only due to the generally large sets of features/operations. Besides the ability to change the set of sequence constraints, also checks upon its semantic correctness are needed, for example checks upon cyclic constraints.

In order to pass judgement upon the sequence results of process planning substeps, feedback must be provided to the user in a format as straightforward as possible to interpret. This is particularly important for the potentially complex constraint structures. A dual presentation is needed in the user interface: a schematic presentation of the features plus their sequence constraints - which can take on network-like shapes - plus a geometrical presentation of the features and the product model. Displaying selections in both views (i.e. selecting a feature in the schematic view highlights it in both the schematic and geometrical view and vice versa) will be a strong visual tool for a user to explore the sequence constraints in a meaningful context. The general idea of this dual

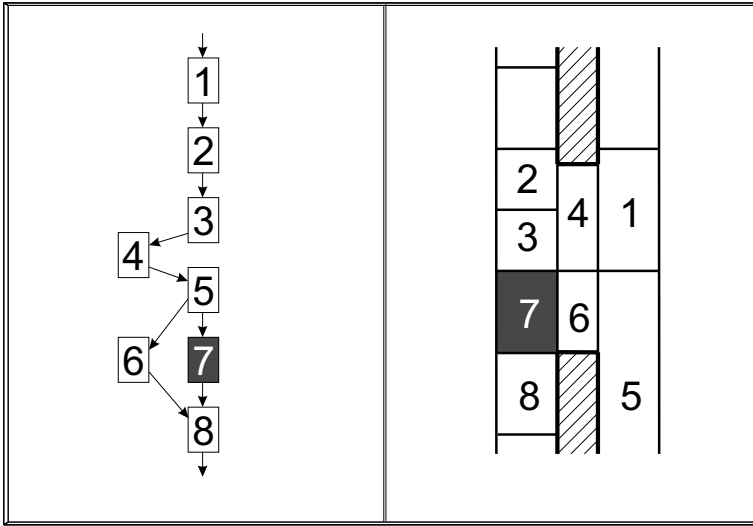

Figure 5.15: The concept of dual presentation of sequence constraints, shown for machining features around a large hole.

presentation is depicted in figure 5.15 for machining features around a large hole. Also, separate commands are conceivable that display these relations, e.g. one that shows all successors of a machining feature.

For operations, reviewing sequence can take on two forms; reviewing sequence constraints on operation level or reviewing the final sequence. For both forms, a dual presentation as described above for features is a suitable tool as well. For the final sequence, network structures will occur far less (if at all), so presentation in a list form will generally provide a good overview. For both forms, separate commands for showing sequence information are conceivable as well.

The application base provides some building blocks for the visualisation discussed here. It offers tree-wise presentation and graphical geometry presentation of features as well as operations, in different views, and selection in these views is coupled. The operation sequence in the tree represents the actual sequence. Separate commands in the tree are available for looking up and editing of operation sequence constraints. Also, operations can be presented in a network structure based on their sequence (Pert view). However, there is no coupling between this view and the graphical presentation, and the view cannot present sequence constraints for features or operations. It must be noted that this Pert view is a third-party component and thus not as open as the rest of the application base.

Feature accessibility

The issue of accessibility is relevant in the application area, especially because of the large resulting feature set. Some of these issues can well be taken on on feature level. On this level, it is assumed that no operations are selected yet for these features, which implies that the cutting tool to be used is unknown and thus cannot be reckoned with. The following issues can be addressed.

Accessibility - or reachability - from a machine viewpoint is determined by the degrees of freedom of the machine. Reasoning with such kinematics requires the machine structure to be known and properly modelled: the configuration of the axes and their rotation and translation ranges. In addition, the placement of workpieces and fixtures for the considered set-up can restrict the ranges and access and thus need to be known as well. The Tecnomatix process planning software provides functionality for such kinematic reasoning; machine kinematics data can be specified through a machine configuration file. The functionality in itself is generic, but is applied selectively, mostly for operation reachability checking.

On feature level, such reasoning is of interest for the determination of machining feature sets (manufacturing methods) for stiffness features. Stiffness features like flanges can have more than one possible tool access directions. By reasoning with the machine kinematics during or just before this machining feature determination, the stiffness features' possible tool access directions can be analysed so that the resulting machining features are reachable. This of course requires the machine tool to use to be selected before this step is performed in the workflow.

From a cutting tool point of view, the local workspace for machining a feature is important, because the available workspace puts restrictions upon the sizes of the tool assembly to use. Based upon the known surroundings of the feature, such limitations can be determined. Although the workspace restriction can be expressed three-dimensionally, a machining feature's working depth is considered the most important. Figure 5.16 shows the working depth for several features. During tool selection, this working depth together with the feature depth can be compared with the tool stick-out length of tool assemblies. The examples shown in figure 5.16 indicate that during determination of machining features, often a good initial value of the working depth can be set, because it typically reasons with information that is relevant here.

The accessibility of a feature also depends upon sequence constraints with other features. Machining features usually have a default machining direction. Features can block each other's machining (tool access) directions. This must be checked with the sequence constraints present; a blocking feature must be sequenced before a blocked feature. In case such accessibility sequence constraints are missing or would conflict with existing constraints, this must preferably be resolved as automatic as possible. Checking whether one machining feature blocks another one's tool access direction can be based upon examining the adjacency of a feature's faces in that direction or other comparable geometric reasoning.

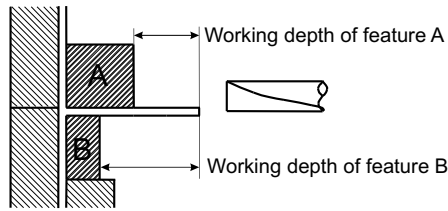

(a) Working depth of rib machining features.

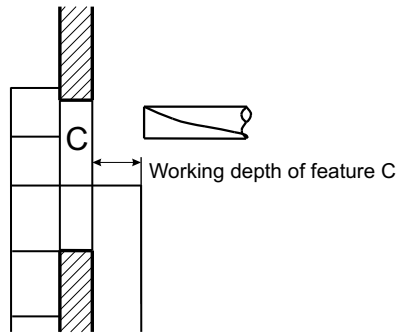

(b) Working depth of hole machining features

Figure 5.16: The meaning of working depth of machining features.

Operation accessibility

Reasoning about accessibility on the level of operations uses more complete data when compared with feature level; machine tool, cutting tool and machining direction are known. So, to verify manufacturability of operations and with that the process plan, at least some checking functionality is needed.

Reachability of position and direction of an operation from the viewpoint of the machine tool can be based upon kinematics reasoning as was described for feature accessibility earlier. The result is handled differently; if an operation is not reachable, it will be up to a user to change this situation. Unlike for features, this reachability checking for operations is readily available in the Tecnomatix machining process planning software.

Whether operation volumes are accessible based upon an operation sequence and the tool assemblies' sizes can be checked by using gouging and collision checking functionality. Such functionality can determine whether a tool assembly accidentally hits the in-process geometry. In-process geometry represents the actual status of the workpiece

for a particular operation, based upon a specific sequence. The volume required by a tool assembly for an operation can be determined by sweeping the tool assembly volume over the tool path trajectory. Whether gouging or collision occurs during an operation can be determined by checking whether this volume and the in-process geometry intersect. Collisions during rapid motions can be checked in a similar way. Again, if an operation results in collision, it will be up to a user to change this situation. Theoretically, it can be possible to determine with which geometry - of which operation - exactly collision occurs, but such a procedure may prove to be very difficult to implement in practice.

Both forms of accessibility verification may seem superfluous on top of the feature level accessibility functionality. They are necessary however, because the relevant data (sequence, selected tools, et cetera) is far more final. Collision checking for fixtures was implemented in *eMPower Advanced Machining* after the project was completed. Gouging and collision checking for in-process geometry was available in earlier versions of the CAPP software, *eMPower Machining*.

Operation sequencing

Determination of the final sequence of operations is best based upon minimising the workpiece's time on the machine. For that, operation sequencing must minimise the non-machining time between operations by minimising the number of tool changes and the overall tool travelling times [Erve 1988]. Tecnomatix' process planning software applies a sequencing algorithm, actually a line balancing algorithm, for sequencing a single setup, based on this minimisation. During this step, all sequence constraints, from feature level as well as operation level, must be obeyed. As the concept of feature sequence constraints is new, software adaptations are needed to let the algorithm take them into account.

Chapter 6

Application development

As indicated in the introduction of chapter 5 software development for this project has been on top of the machining process planning software by Tecnomatix. The working conditions were such that there was much access to the source code of this software, which eased extending and adapting it. Most development has been done using C++.

There have in fact been two implementation stages during the course of the project. The first implementation was of a prototype nature, based on *eMPower Machining* (formerly known as PART, see also section 1.4 and 2.3.5). In this, the viability of methods was proven for relatively simple geometry cases. As results were promising, it was decided to work up to a fully functional process planning system. This has been carried out based upon the *eMPower Advanced Machining* software. This is a completely new implementation based on the concepts of the PART application, in which the software and data structure basis have drastically changed. The switch of application base required time and effort for design and implementation adaptation. Changes however never compromised any concepts. The system formed a relatively open basis for development. The program is also more user friendly and has more interactive editing possibilities than the PART system. These benefits outweighed the drawbacks.

The following sections describes the realisation of the subset of the functional design from chapter 5 that has been implemented into software.

6.1 Product model interpretation

In this project, product model interpretation for a part takes place in the context of a machine environment, i.e. a setup. This context and how it helps interpreting structural data is essential for following planning tasks, as explained in the previous chapter.

6.1.1 Stiffness feature recognition

As described in section 5.4.1, stiffness feature recognition uses software based upon the work as described in [Houten 1991] and [Geelink 1996], which is available in the Tecnomatix software for machining. The recognition is face-based and uses pattern matching. Recognition algorithms for the three main types of walls have been added; straight ribs, flanges and walls (webs). These algorithms are much based upon the large side faces of these features. For example, coplanar faces are considered part of the same wall as a means to handle intersecting (crossing) walls, so that recognised walls of the several types are as large as possible. These feature types have high recognition priority, so that they take precedence over other types during recognition.

Upon the level of application software, little adaptation was needed. Stiffness features were added to the data structure as inheriting from the application's common features, and the software was adapted further to let the recognition command create stiffness features instead of machining features. Two supporting pattern recognition functions were added for finding coplanar faces and for finding the nearest offset parallel planar face, respectively. Finally, in the prototype version of the software, relative wall sizes were assessed in a post-processing step to determine whether a wall is really thin, i.e. whether stiffness support is needed during machining. This assessment used static bending formulas.

6.1.2 Connection determination

Both the connection relations and automatic determination of connections between stiffness features were implemented in the prototype software version. This prototype determination is based upon some presumptions about data. Two reasoning procedures are used. The first procedure creates a *base-leaf* connection between two features if the origin of one feature (leaf) is upon a face of the other feature (base) and at that origin, the normals of these feature's faces are parallel. (The faces of the feature's volume representation are considered.) The meaning of a base-leaf connection is that the leaf feature is considered to be on or in the base feature. The second procedure checks for any intersection or adjacency between feature volumes. A base-leaf connection is created if these features do not have a base feature in common, neither directly nor indirectly, otherwise a *crossing* type of connection is created. The set-up for the workpiece is considered to be known, as well as the workpiece's placement in the set-up. The second procedure uses the features' distance from the machine's table to determine which feature is higher in the set-up, to help decide which feature is the base or leaf for a base-leaf connection. This prototype connection determination was especially aimed at finding connections between wall features, but produced good results. The procedures were designed and developed by Post [Post 2001].

Neither connection relations nor automatic determination of connections was implemented in the final software, because other development tasks were considered to have higher priority. In order to reason with connections as a relation, stiffness feature types

have been extended with two parameters: HSM_ID (only protrusion feature types) and HSM_BASE_ID (all feature types). These parameters are used to represent base-leaf connections; if a feature's HSM_BASE_ID equals another feature's HSM_ID, the latter feature is base feature of the former feature. At this point, a user thus needs to set these parameters by hand.

6.1.3 Stiffness feature accessibility

Section 5.4.3 discusses how reachability of the possible machining directions (or tool access directions) of a stiffness feature can be analysed. It requires the placement of the workpiece in a set-up to be known, as well as the machine used for the set-up with the configuration of its axes.

In the eMPower Machining systems, the machining directions of features are coupled to the direction of their origin (coordinate system). The two main sides of a wall can however be machined from different directions. For wall stiffness features, the tool access directions have been decoupled from the feature origins. The tool access directions for the two main sides of a wall are represented as separate parameters.

In the prototype software version, the possible tool access directions for walls were checked for machine reachability with respect to orientation. This information is especially useful during determination of machining features for the stiffness features.

This functionality was not implemented in the final software, because other development tasks were considered of higher priority. The latter choice was also influenced by the fact that the axis configuration of the high-speed milling machines of interest for the project hardly restricts feature reachability.

6.2 Planning intermediate workpiece states

Sequence constraints and removal features (machining features) are in essence a way to manage the intermediate states of a workpiece in a way that takes on the stiffness issues of a product. The following sections discuss development of the functionality to plan these intermediate states.

6.2.1 Stiffness feature sequence constraint determination

Section 5.3.2 discussed how stiffness feature sequence constraint determination must apply knowledge rules. The functionality has been developed from scratch instead of basing it upon existing knowledge modules, because the used approach differs too much from method selection.

The implemented algorithm first runs over all stiffness feature combinations (pairs) and checks each pair against all available rules. This phase checks which rules are

applicable in which cases and in what sequence constraints they would result when applied. The second phase is the rule application phase. The found applicable rules are tried in order of priority, regardless of the associated stiffness feature pair. A rule is only actually put into effect if the sequence constraint resulting from it does not cause conflict or redundancy with existing feature sequence constraints.

The knowledge rules that have been implemented, five in total, currently seems sufficient for usage at Fokker Aerostructures.

6.2.2 Machining feature determination

Machining feature determination for stiffness features has been implemented based upon the software available for method selection. Section 5.3.1 already discussed differences in knowledge and reasoning from operation method selection. The following subsections describe how these differences are dealt with in the implementation. They will go into the implemented knowledge and the the software executing the knowledge, respectively.

Knowledge implementation

What knowledge has been implemented for machining feature determination will be discussed separately from how it has been implemented. Because of the differences with operation method selection, special attention is paid the how, the knowledge structure.

Knowledge content

The knowledge set implemented for machining feature determination largely corresponds with the knowledge described in section 4.1.3. Knowledge has been implemented for stiffness feature walls, cut-outs, holes, chamfers and fillets. Fourteen feature types (of five categories) are supported. The knowledge for depression stiffness feature types, as described in section 4.1.3, is an adaptation of the step strategy of the associated wall and thus cannot be executed independently. Section 6.1.3 describes that separate parameters express the tool access directions for the two main sides of a wall. These parameters are used in the machining feature determination knowledge. However, as the axis configuration of the high-speed milling machines relevant to the project hardly restrict feature reachability, the knowledge interprets the parameters as *preferred* machining directions. If a direction indicated by the feature parameter is not supported by the knowledge, machining features will be placed based upon the default tool access direction.

The machining feature size calculation described in section 4.1.2 has been implemented as a separate calculation function, which is accessible by the knowledge. The calculation is performed as described in section 4.1.2. The function is used in the knowledge to calculate the permissible height values for wall machining features. The needed machining feature width is determined directly in the knowledge. The calculation function takes as input wall sizes, an effective length ratio, machining-related parameters, material parameters and a permissible deflection.

Machining-related parameters, especially data concerning preferred tools, have been expressed as constants in the knowledge library (a knowledge editor can change them). No tools are selected.

Knowledge structure

The used knowledge structure is based upon the structure described in section 4.1.4 (figure 4.13), although knowledge blocks have been combined to ease implementation. When a wall is processed, first the collective properties of its connected stiffness features are determined, for example the step separation line for large holes (see section 4.1.3). This is followed by the main knowledge block for a wall. It determines the machining feature sizes for the wall and accepts the influences of all connected (base or leaf) features. Subsequently, the influences of the wall and its machining features upon the connected features is processed. This concerns for example the influence of the permissible machining feature height upon other machining features. Also, data concerning machining feature sequencing is passed on and processed, like putting the machining features of holes into the sequence of a wall's machining features.

In realisation of machining feature determination using the method selection technique and software, two main issues to address were noted in section 5.3.1.

First, specific relations between features are explicitly reasoned with. Due to the importance of these relations, they should be expressed explicitly. The relations themselves have not been made available in the knowledge reasoning and editing software. Both connection data and sequence constraint data is expressed through feature parameters in the knowledge. Connections are expressed using the ID-parameters described in section 6.1.2. Sequence data is expressed through local enumerators.

Second, the number of input features for a knowledge set is unknown, as well as the number of output features. Method selection as is expects the number of input and output features for its knowledge rules (methods) to be known. This has been resolved using two approaches: using 'data carrier' features for intermediate data and repeatedly calling of the same rules. Data carrier features are separate types. In the knowledge, the data carriers are created and initialised for each wall. Then, a rule is called - repeatedly - in which such a data carrier feature 'visits' connected features. For example, each hole feature in the input set is called on by a data carrier feature, and if it is a leaf feature of the associated wall feature, relevant data is updated, like a preliminary step separation line. The repeated calling ensures that the data of all hole features is processed. The information in the data carrier features is used among other things in the wall machining feature determination. The influence of a wall and its machining features upon leaf features is processed similarly. After the wall machining features have been determined, the features connected to the wall are visited again (if necessary) by data carrier features, in knowledge rules in which the influence of the features of the connected wall on the leaf features is processed.

The unknown number of output machining features for a stiffness features has been addressed by recursively called rules which splits machining features. For a wall, for example, machining features are initially created as two large blocks, although the ac-

tual machining feature heights are known. The splitting rule is recursively called on these blocks until the machining feature blocks' heights no longer exceed the calculated permissible heights.

Command implementation

Besides expressing machining feature determination knowledge in a form that the available method selection software can deal with it, the software must create machining features for stiffness features instead of operations for machining features. This has been done by a wrapper implementation; the method selection software is used inside the machining feature determination software and extended with pre-processing, batch handling and post-processing functionality.

The pre-processing step is responsible for validating the input. It especially checks whether machining features were already assigned to input stiffness features earlier, and whether the connection structure (indicated by the HSM ID parameters) is semantically correct.

The knowledge reasoning is divided into batches for reasons of performance and capacity of the command. The batches are determined on beforehand. Each batch consists of a wall and its connected depression leaf features. Reasoning starts with the root base features, i.e. base features that are not in or on other features. If such a base feature wall is base feature to another wall, the relevant information is passed on to the batch of the leaf wall feature by means of a data carrier. This way, a wall can influence machining features of leaf wall features despite the batch-wise reasoning.

The method selection software will create output in another format than desired, expressed in terms like operations, and intermediate features with dummy parameters. The post-processing step is responsible for extracting the determined machining features, their sequence constraints and their relations with stiffness features from this output, and for cleaning up any intermediate data. The machining features, and to which stiffness feature they belong, are derived from the generated operation structure, and type and status information. The sequence constraints between machining features are derived based upon the sequence parameters of the features, plus assumptions about the data created by the knowledge, i.e. between which machining features (of which stiffness features) sequence relations can be created. Only stiffness features that have been solved together can get sequence constraints between their machining features. Last, data concerning dummy operations and intermediate features, that is no longer necessary, is deleted.

6.2.3 Tools for modification of machining features

This section discusses the implementation of the functionality described in section 5.4.2 that was realised.

Machining feature adjacency determination

The adjacency of machining feature faces - to faces of product geometry or faces of other machining features - is important for operation computation and for machining feature recognition; see section 5.3.3 and 5.4.2, respectively. Due to its high relevance, the realised functionality is discussed separately here.

Machining feature adjacency determination has been implemented through geometric reasoning functionality. This geometric reasoning can be summarised as checking whether two faces of the feature volume (partially) coincide, where the coincident geometry must be one or more faces, i.e. not only edges or vertices. This can be used to determine whether faces of a machining feature are adjacent to part faces, but for adjacency between machining features mutually, additional logic is needed. As described in section 5.4.2, machining features should only be considered adjacent if neither of them has been removed yet. The adjacency logic therefore also considers sequence constraints. It only considers faces of machining features that are not predecessors of the machining feature being analysed.

Dedicated machining feature recognition

As discussed in section 5.4.2, dedicated machining feature recognition takes an existing feature's geometry as input; see also figure 6.1. This volume must exactly match a feature definition to be recognised (no intersections); in this sense, it can also be considered as *classification* of the volume as a feature. Recognition functionality for a feature type consists of three portions: shape recognition, adjacency recognition and parameter extraction. Shape recognition checks the geometry's shape against the definition, and adjacency recognition checks whether the right faces of the feature geometry are closed (adjacent) or open (not adjacent), using the adjacency determination described above. Parameter extraction determines the feature parameters, including which kind of faces of the feature are product adjacent.

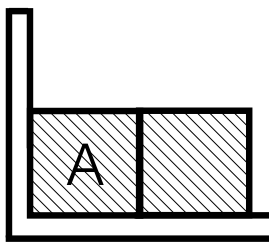

Figure 6.1: Machining feature recognition analyses the feature volume.

This recognition is used as an internal component as well as a separate command available in the user interface. In both cases, recognition is tried in order of feature priority; the first type that is recognised is instantiated. The command however first tries to validate the existing feature type, i.e. recognise the type that the input feature

is, so that if it suffices, the same feature with updated parameters results. The command also leaves the current feature if it cannot recognise it. The internal component form in that case will create an *unknown shape* feature and will save the geometry plus adjacency information with it, so that a user can edit the result. To guard feature accessibility, a feature is only considered recognised if the new feature's machining direction is the same as the original one.

The recognition currently supports sixteen feature types, including four 2.5D free-shaped types. It must be noted that feature types have been 'relaxed'; a round hole is for example recognised as a rectangular hole without straight side faces. (Operation method knowledge has been defined using the same relaxation.) Ten additional feature types are indirectly recognised this way.

Interference handling

The interference handling algorithm, needed to resolve machining feature volume overlap, is built up from the following actions. First, interference detection takes place, based upon geometric boolean operations. Machining feature interferences with part geometry and with other machining features can be handled. Second, it must be determined from which geometry the overlapping volume must be subtracted. This is trivial for interferences with part geometry. For feature-feature interferences, however, this choice should preserve the feature that requires most attention during machining. This is determined by knowledge rules, similar to those used for stiffness feature sequencing (see section 6.2.1). For the pair of features involved in an interference, the applicable rule with the highest priority is determined and applied, meaning that it chooses the feature to preserve and the feature to subtract from. These rules have been implemented based upon the stiffness features that own the interfering machining features. Third, the actual subtraction is performed for all found interferences. If the changing feature is involved in other interferences, these interferences are updated with the changed geometry. Fourth and last, the subtraction results - the changed features - are processed for all interferences. The resulting feature geometry is automatically recognised using the above described machining feature recognition. The original (outdated) features are replaced by the recognised features in the datastructure; the original relations are redirected to these new features. This processing can also handle cases in which subtraction causes the changing feature to be split or to disappear.

A small set of knowledge rules (three in total) has been implemented in the system, and seems sufficient for usage at Fokker Aerostructures at this point. The user interface offers commands for interference detecting and resolving upon different scopes, from finding product interferences for a single feature to resolving all interferences for all machining features in a set-up. This gives a user more control over the end result.

Machining feature modelling

In *eMPOWER Advanced Machining*, a sketcher is available for sketching operation boundaries, operation tool paths and such. In the context of the project, this functionality has been made available for free-shaped feature types as well. A user can sketch a closed two-dimensional feature profile, from which a 2.5D feature volume is derived by a straight sweep of the profile area, perpendicular to the sketch plane, along the depth of the feature. Additional commands were implemented so that a user can derive a profile from an existing feature volume and change the feature into a free-shaped type. This is meant to ease editing of existing features.

Through existing functionality, a user can attach a geometric model to a feature, which is then shown and used in the software. Such a model can thus be edited using other modelling software (in which however the context of the feature - product model, other features - will be missing).

6.2.4 Tools for reviewing feature relations

Commands have been implemented for viewing as well as editing of feature sequence constraints, on both stiffness feature level and machining feature level.

For a feature, its predecessors or successors can be displayed, and for stiffness features also simultaneous features. Besides directly related features, a user can also view indirectly related ones, for example stiffness feature successors when simultaneous relations are considered, or all machining feature predecessors when stiffness feature sequence relations are considered. There are also commands for displaying the machining features belonging to (i.e. owned by) a stiffness feature and vice versa.

For editing the relation structure, commands are available to add and delete feature sequence relations and ownership relations. To ensure validity of the structure, it is checked whether the addition of a feature relation is allowed (semantically correct and consistent) before it is applied.

6.3 Operation determination

Implementation of operation determination has remained limited due to time and priority restrictions. The realisation of functionality has been aimed at validating the devised core concepts. Realised functionality is described in the following subsections.

6.3.1 Architecture - controlling modular tool paths

On module level, little adaptation has been implemented on top of the existing structure described in section 5.3.3. Within the module, the generators to apply can be specified per operation type. One domain-specific operation type has been implemented. For this

type, only different boundary and pattern generators are applied when compared with similar 2.5D operation types.

The handling of different tool path layers can also be considered a module-level issue. For existing 2.5D operation types, the pattern generator creates one layer. Given a depth of cut and an operation depth, one of the following generators copies the tool path layer as often as needed. As section 4.3.4 describes, different tool path layers for a single operation can be in demand for high-speed machining of thin geometry. Section 5.3.3 therefore considers different handling of layers on module level; storing generated layers and selectively copying them. For ease of implementation, however, the described copying mechanism is reused. If alternating layers are in order, these are generated and copied together. If a separate finishing layer is needed due to bottom face product adjacency, it is created through a separate finishing operation.

6.3.2 Generating modular tool paths

The implementation of the creation of the dedicated tool path patterns will be discussed below. Subsequently, the related boundary calculation is discussed, together with its relation to the pattern algorithm.

Patterns

2.5-dimensional machining features can have outside contours that are all closed (e.g. pockets and holes), all open (e.g. surfaces) or partially open (e.g. notches). The *eM-Power Advanced Machining* software as is provides (third party) 2.5D tool path pattern algorithms for all three kinds of contours; pocketing, facing and profiling. The new application area however poses additional demands, as described in section 5.3.3.

It has been chosen to implement a new tool path algorithm based upon the 2.5D profiling algorithm provided by *Advanced Machining*, for the following reasons:

- the algorithm's internals provide control upon the level of individual side passes, thereby providing good pattern building blocks,
- a majority of the 2.5-dimensional machining features in the application area will have partially open contours.

The unadapted profiling algorithm creates side passes by a form of offsetting from the boundary elements, as shown in figure 6.2. It can generate zigzag patterns, which is preferred for this application area. It can also create one-way patterns, which is needed for down milling product adjacent bottom faces. Both pattern forms rely on the control upon side pass level noted above. Whether or not to use up or down milling at the boundary is a standard (even mandatory) input parameter.

Detail design and implementation of the algorithm adaptations have been carried out by Hagen [Hagen 2004]. The ability to generate the pattern pass by pass is utilised, as

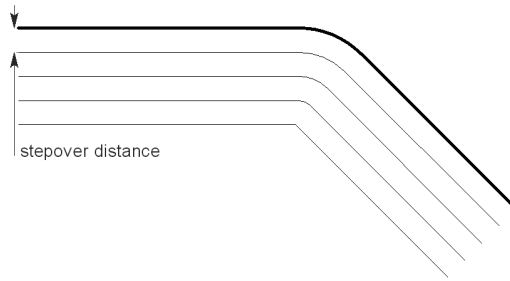

Figure 6.2: The working of the existing profiling algorithm in *Advanced Machining*.

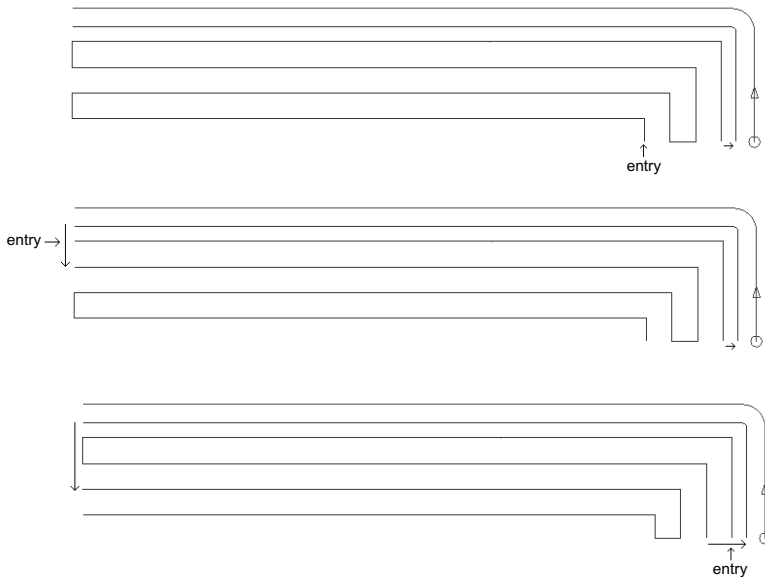

Figure 6.3: Example tool paths generated by the adapted algorithm for a product adjacent corner notch, after [Hagen 2004]. The upper right line is the product adjacent boundary.

is the offsetting mechanism and the side pass connecting mechanism used for creating zigzag patterns. These enable creation of continuous patterns for a layer with a reduced stepover only at boundary adjacent side passes, and/or with a 100% stepover (full cut) side pass, while remaining passes have the regular stepover. In other words, they enable creation of the needed regions within a layer. Creation of a smooth run-up to a product-adjacent side pass is realised by enforcing an extra entry at that pass. That entry will behave the same as the general entry of the pattern, and can thus be made smooth by setting the appropriate pattern entry parameters. Alternating layers, as mentioned before, are created together. In order to do so, the algorithm requires the depth of cut

to use, to create the proper offset in the depth direction. Different layers are created by enforcing the second layer to start at the other end of the boundary. Enforcing a starting side will, together with the down milling constraint, result in an enforced full cut. Table 6.1 shortly lists the application area specific input parameters that have been added to the algorithm. Figure 6.3 shows example pattern layers generated by the algorithm.

Input parameter	Meaning
HsmProductBoundaryType	flag indicating whether the boundary is product adjacent
HsmBoundaryStepover	the stepover to use at product adjacent boundary elements
HsmBoundaryEntryExit	flag for creating an adapted run-up (entry/exit) at a boundary adjacent pass
HsmMirrorZlevels	flag indicating whether alternating depth steps are created
HsmFullcutDepthFactor	reduction factor of the layer depth of a full cut
HsmPreferredEntrySide	flag for enforcing a pattern entry side (boundary end), which can enforce a full cut
HsmRefBoundaryCutSide	side of the reference boundary on which passes are trimmed

Table 6.1: Application area specific input parameters for the adapted profiling algorithm.

Boundaries

As noted in section 5.3.3, the application area requires the full profile of the volume to machine to be known. This is on one hand the case because the whole volume needs to be machined; for the application area, machining features are in essence *removal* features. On the other hand, the volume's borders may not be exceeded too excessively to prevent re-machining of already thin part geometry.

Figure 6.4(b) shows a profiling pattern generated along product geometry, for the workpiece of figure 6.4(a) (pattern adaptations are omitted for clarity). The figure shows the deficiency of the algorithm that it does not fill out the pattern for the entire cavity to machine. Without adaptation, the profiling algorithm is not aware of the full contour of a volume. Additional measures are needed if 2.5-dimensional features of any form are to be completely machined with this algorithm.

This issue is resolved as follows. The input is changed so that the generated pattern path will exceed the volume to machine, as shown in the example in figure 6.4(c). The part of the volume contour which is not used as input for the profile is then used as reference boundary. The reference boundary is used to trim the excessive tool paths. Trimmed path elements are reconnected to keep the path continuous. The connecting path elements follow the reference boundary. Figure 6.4(d) shows an example result.

Advanced Machining provides an auxiliary type of boundary geometry (not used for existing 2.5 dimensional operations). This type is used as reference boundary for the new modular operation type. The system provides sketching for all its boundary types, so a user can edit these boundaries. A trimming and reconnecting mechanism has been

built into the pattern algorithm. Both concept and algorithm implementation have been worked out by Hagen [Hagen 2004].

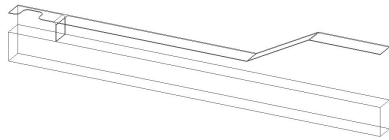

(a) *Sample workpiece (thin product geometry, thick machining feature geometry)*



(b) *Tool paths generated for the product adjacent boundary by standard profiling*

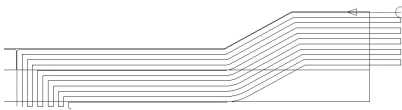

(c) *Tool paths generated for an extended product adjacent boundary*

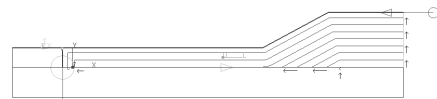

(d) *Extended tool path pattern, trimmed using the remainder of the volume contour*

Figure 6.4: Generating a pattern to machine an exact volume requires special measures (figures after [Hagen 2004]).

For automatic determination of the boundaries, procedures have been designed by Hagen [Hagen 2004]. This design will be briefly described. The procedures start with deriving a contour from the intersection of a slice plane with the volume to machine, and storing the adjacency of the contour elements. The procedure for the profiling boundary then roughly speaking determines the half of the contour that contains the most product adjacent elements and saves it. (It can thereby also deal with cases where product adjacent elements are not all adjoining to each other. If no elements are product adjacent, machining feature adjacent elements can be used instead.) The procedure for the reference boundary in essence determines the remainder of the volume contour. If this contains product adjacent elements, these are offset towards the inside of the contour. The offset elements are connected with the other reference boundary elements. These product adjacent elements will need a final pass with product finishing conditions. The adaptation leads the reference boundary around that pass. The product adjacent contour elements that don't belong to the profiling boundary are stored as separate (rest product) boundary. A further adapted version of the pattern algorithm will use this boundary to create finishing passes for these elements.

Time and priority considerations led to a very simplified implementation of the boundary generators. The profiling boundary generator stores the contour elements from the volume intersection that are product adjacent. The reference boundary generator stores the other (not product adjacent) elements; no distinction is made between open contour elements and elements adjacent to other machining features.

6.3.3 Steering modular tool paths - knowledge

This subsection will mainly focus upon the modular tool path aspects of the application area specific operation knowledge. Machining features hold an adjacency parameter, which indicates the type of face(s) being product adjacent (bottom, side, both or none). This parameter plays a major role in the implemented knowledge.

As noted in section 6.3.1, in case of bottom face product adjacency, a separate operation is created for the bottom tool path layer in order to locally enforce the associated application area demands. This operation method applies a reduced depth of cut, reduced stepover and down milling, thereby enforcing one-way paths for the profiling algorithm. The previous subsections also describe how alternating layers will be created and copied as a pair. This implies that an even number of depth steps results when alternating layers are applied. In case an uneven number of alternating layers is in order, method knowledge will generate the additional layer as a separate operation. Depth of cut and the number of axial passes are thus explicitly reasoned with and set in the operation knowledge. A general set of method types for a feature is thus formed by a bottom layer operation method, an operation method for an uneven alternate layer and a main operation method for the other layers. Each operation method is only applied when needed.

The operation method knowledge steers the modular tool path algorithm using conditions that essentially concern operation adjacency and efficiency. The settings for bottom face product adjacency were already discussed above. Other layers will receive a zigzag-type pattern by default. In case of side face product adjacency, the algorithm is instructed to create the profiling boundary adjacent side pass with specific settings: down milling, a reduced stepover and a smooth run-up (circular entry) to the pass. Sharp corners in this boundary adjacent pass are avoided by selecting a tool with a smaller diameter than the smallest feature corner. For specific types (like slots), layers with full cuts are enforced, regardless of their adjacency. Layers with a full cut are applied with a reduced depth of cut. The following efficiency criteria are applied. In case an even number of side passes is used, no alternating layers will be used. In case an uneven number of side passes is in order, settings further depend upon the side adjacency. In case of non-product side adjacency, alternating layers will be used without applying an full cut. In case of product side adjacency, alternating layers would require at least one of the alternate layers to have a full cut, and thus a reduced depth of cut, which can result in additional depth steps. So, in that case, the resulting total number of side passes for the operation is calculated for an alternating pattern and for a non-alternating pattern. An alternating pattern, with full cut, is only applied if its total number of side passes is lower than that of the alternative. Operation method selection is also responsible for extending the tool path for later trimming by the reference boundary (see section 6.3.2).

Operation method knowledge has been implemented for ten feature types, using 26 methods. The 'relaxed' feature types used for feature recognition (see section 6.2.3) are also 'relaxed' in the methods, so implicitly ten more kinds of features are supported.

6.3.4 Cutting conditions

The previous subsections describe how the geometric cutting conditions are in fact set during method selection in the current implementation. A factor in this choice is the optimisation endeavour during method selection.

The local application of finishing feed rates and/or speeds, described in section 5.3.3, has not been implemented. Also, the application does not use empirical cutting data from Fokker Aerostructures, although this has been considered during the project. Instead, they use the standard mill technology cutting model available in the Tecnomatix software.

Chapter 7

Results

This chapter presents the results of the work carried out for this project. Section 7.1 means to present the resulting software by means of an example user session. Practical usage of the software is discussed in section 7.2, which describes the findings of Fokker Aerostructures.

7.1 An example process planning user session

The following section describes a general user session, based on the workflow tasks outlined in section 5.1, in which the software is used to create a process plan for a thin-walled part. The steps will be explained with screen shots of the user interface, in which special attention is given to the software implemented in the context of the project.

Figure 7.1 shows the user interface of the *eMPower Advanced Machining* software. Main elements are the tree view on the left, the graphical view on the right and the table view on the bottom. The tree view shows elements in a project in a tree structure. The graphical view shows geometrical presentations of active elements, e.g. part models, features or operations. The table view shows data or relation attributes of active elements, according to pre-defined table configurations which the user can choose. Each view has its own toolbar (in addition a sketcher toolbar and a line balancing toolbar are available). Most commands are however implemented on the nodes (data elements) that they apply to. They can be called through the context-sensitive menu that appears when a node is right-clicked in e.g. the tree view.

When an end-user starts from scratch, he (or she) will first need to perform some preparation steps before he can start actual planning. He must first create a new project, and a machining process within the project. Then, he needs to couple a machining environment with the project. The machining environment generally describes the company-specific resources such as machines, fixtures and cutting tools, but also material and cutting technology data. He also needs to couple the relevant knowledge rule libraries to the project, i.e. the knowledge rule sets for machining feature determination and for machining operation determination, respectively.

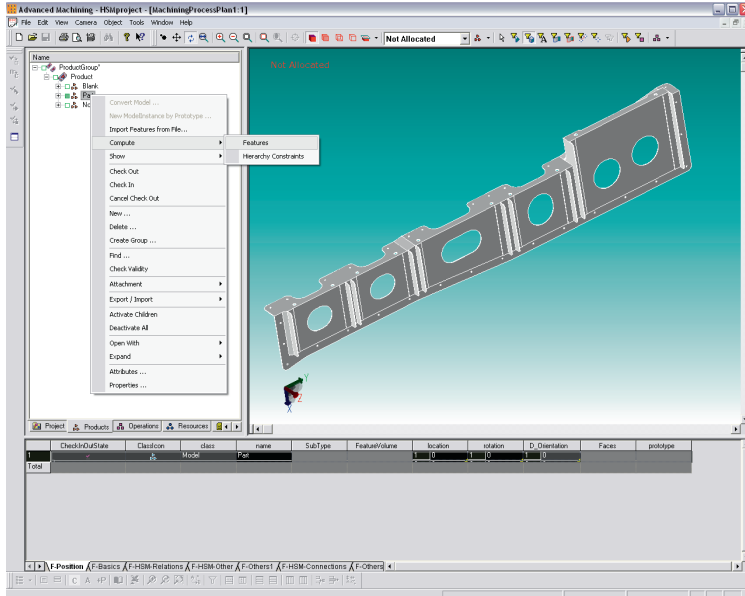

Figure 7.1: The Stiffness Feature Recognition command

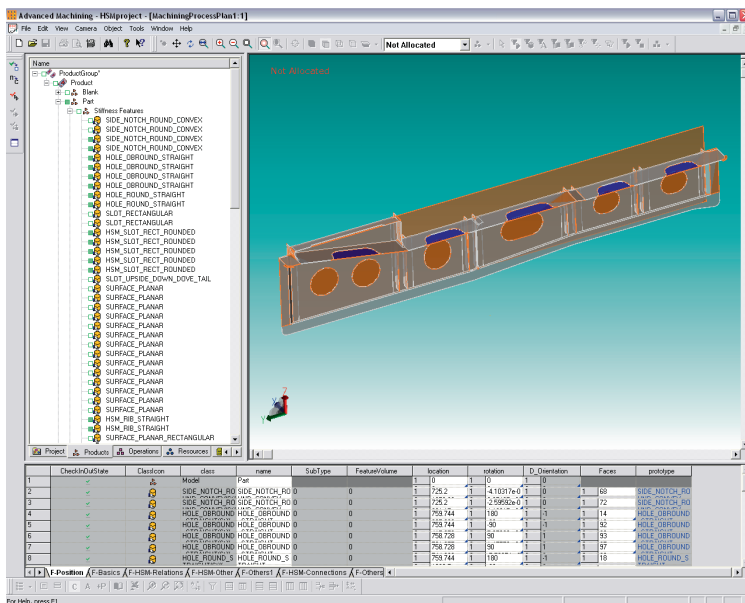

Figure 7.2: Stiffness Feature Recognition result after editing (shown in transparent mode)

Actual process planning starts with creating a new product and reading in geometric product model data for it. A user can also select a material for the product at this point.

Now a user can call the Stiffness Feature Recognition command on the part, as depicted in figure 7.1. Figure 7.2 shows part of the recognition result, after some detail editing on walls and cut-outs. For editing the features' placement and sizes, the software offers some intelligent alignment and geometry interrogation functionality.

As most of the remainder of the process planning workflow requires the context of the used set-up, a user must specify this set-up. He must create the set-up node, assign a tool set and machine tool to it, and allocate the product to it, which creates a set-up specific in-process model node. As products are often machined in multiple set-ups in standard machining, the stiffness features need to be allocated to the set-up explicitly.

The next step is to determine the physical connections between stiffness features, which is at this point an interactive task as described in section 6.1.2; manually setting the connection ID parameters of the features.

Following, the rule-based automatic stiffness feature sequence constraint determination can be executed. Figure 7.3 shows the command call and the result. It shows for example that cut-outs (HSM_SLOT_RECT_ROUNDED) will be manufactured with the flange they are in, and flanges will be machined before the main wall. A user can review and edit the sequence relations through dedicated commands.

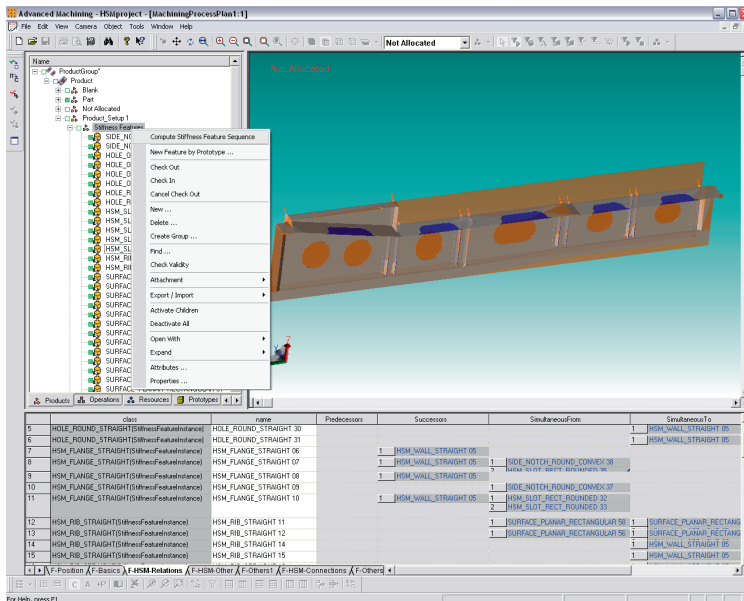

Figure 7.3: Stiffness feature sequence constraints determination. The table view shows the resulting sequence constraints.

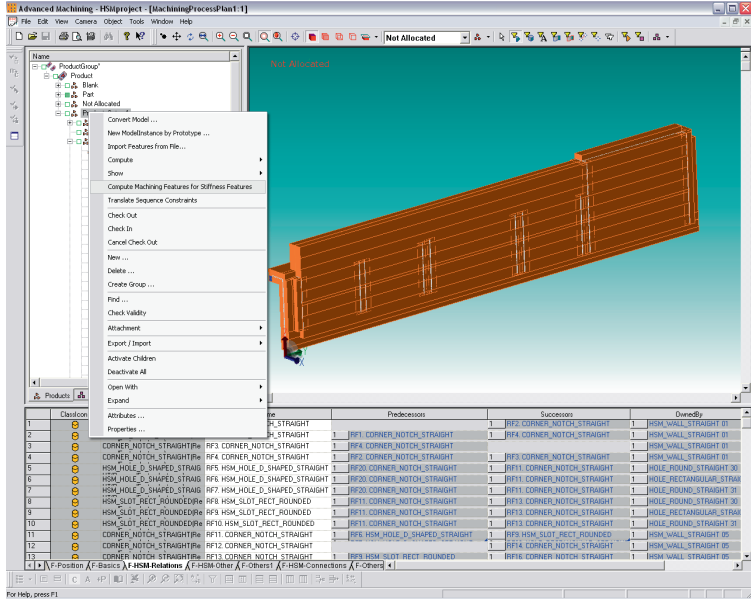

Figure 7.4: The machining feature determination command plus the resulting machining features. The table view shows the sequence constraints and ownership relations.

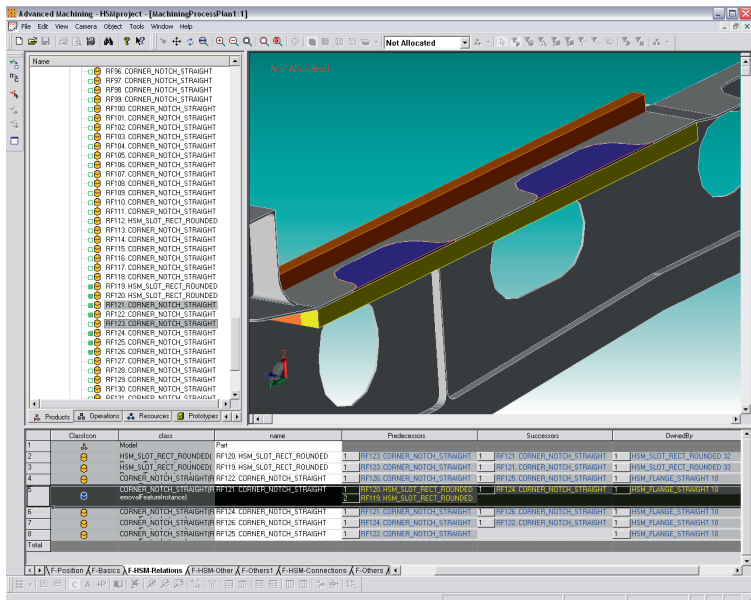

Figure 7.5: Machining features with sequence constraints determined for a flange with cut-outs (not all machining features are shown graphically).

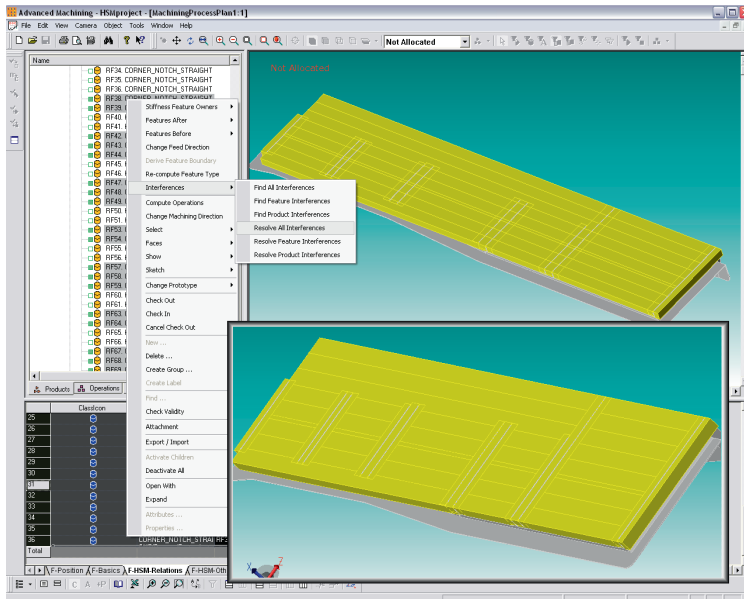

Figure 7.6: Interference handling on a selection of machining features, with the resulting features shown in the inset

The next step is the automatic determination of machining features and their sequence constraints for the stiffness features, as shown in figure 7.4. Domain-specific commands like this and the sequence constraint determination command are only available under the context of the set-up, i.e. under the in-process model node of the set-up.

Figure 7.5¹ zooms in on results for cut-outs in a flange, for which the strategies were described in section 4.1.3.

Subsequently, a user will review the results and edit machining features and sequence constraints where necessary. Figures 7.6 and 7.7 show such editing. The submenu in figure 7.6 shows the available commands to handle machining feature interferences, and the result of execution of one of those. Figure 7.7 shows substeps of turning a machining feature into a free-shaped type. After deriving the feature boundary of the existing feature, the feature type can be changed into a free-shaped type, and a user can edit the boundary sketch to change the shape. The menu in figure 7.7 also shows other entries for reviewing, like *Re-compute Feature Type* and the first three submenu's, that hold commands for viewing and editing machining feature relations.

When satisfied with the features and their sequence constraints, a user can determine the operations for each machining feature, as shown in figure 7.8. This command, which is part of the application base, applies the knowledge described in section 6.3.3.

¹The cut-out machining features should not be slots but partial slots, but the latter feature type was not yet available when the machining feature determination knowledge was being implemented.

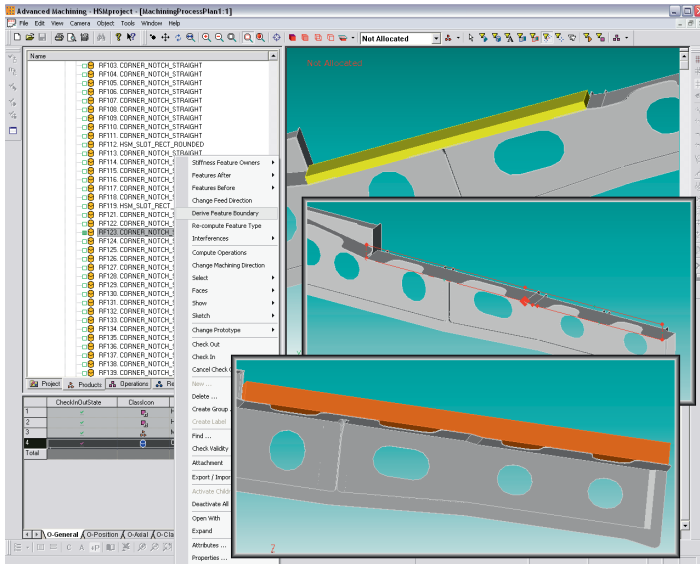

Figure 7.7: Phases of making a free-shaped feature: deriving a boundary from an existing feature, editing the feature boundary sketch (first inset) and the resulting feature (second inset)

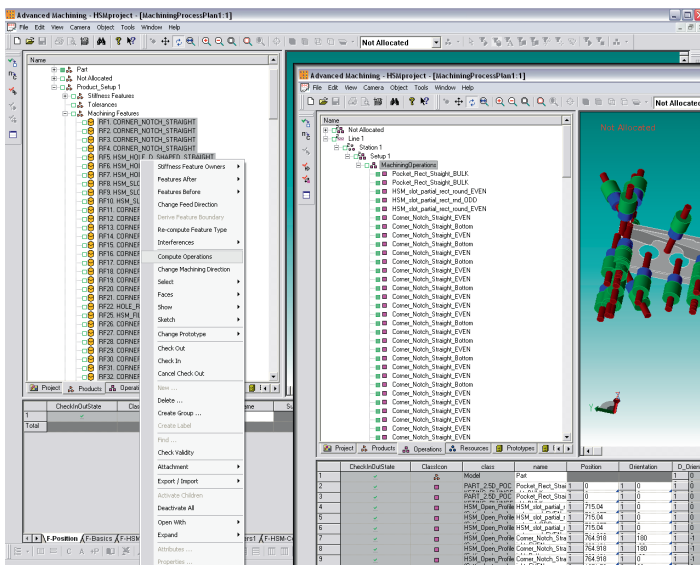

Figure 7.8: Determination of operations for a selection of machining features, with the resulting operations shown in the inset

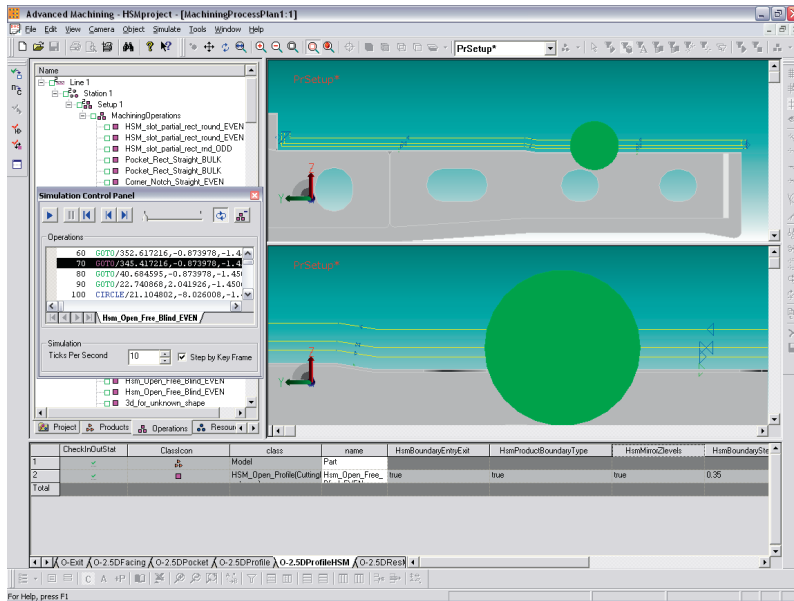

Figure 7.9: Simulation of a machining operation for thin walls; the lower half of the graphical view is zoomed in on the right-hand portion of the operation

After generating the operations, a user can detail them by editing and calculating tool paths and cutting conditions. Figure 7.9 shows the resulting tool path for an operation for thin walls. The green circle is the tool assembly, viewed from the top. The pass adjacent to the part has a visibly lower stepover. In the lower half of the graphical view, the arrows are visible that indicate the path direction. The middle pass shows two opposing arrows, which indicates that the pass direction is different for subsequent depth steps. In other words, on every second depth step, a full cut is applied.

Figure 7.10 shows the translation command responsible for ensuring that the sequence constraints for the features are also enforced on the operations for those features. Figure 7.11 shows the views commonly used while sequencing operations: the line balancing view and the Pert view. The line balancing toolbar with among other things the sequence constraint filter is on the right (other filters are the reachability filter, the tools filter and the time filter). Operation sequence viewing and editing is part of the application base.

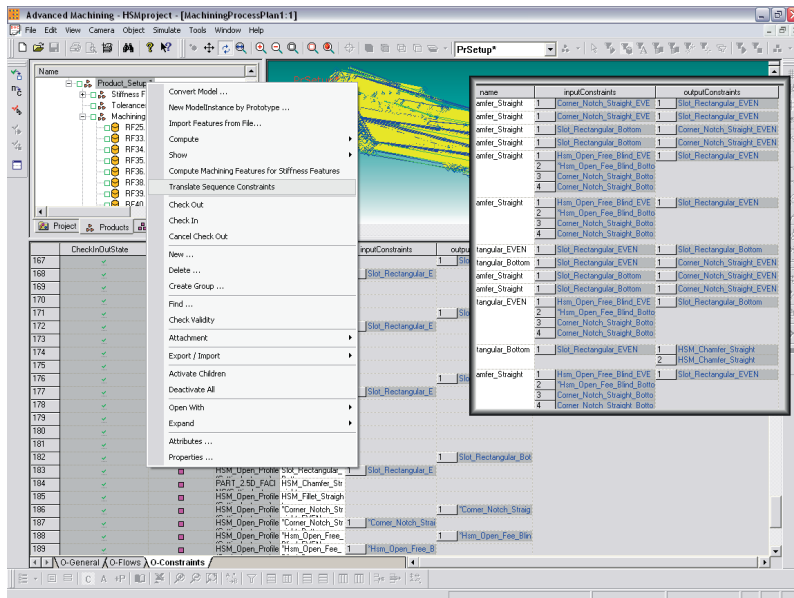

Figure 7.10: Translation of feature sequence constraints to operation sequence constraints; the resulting new operation constraints are shown in the inset

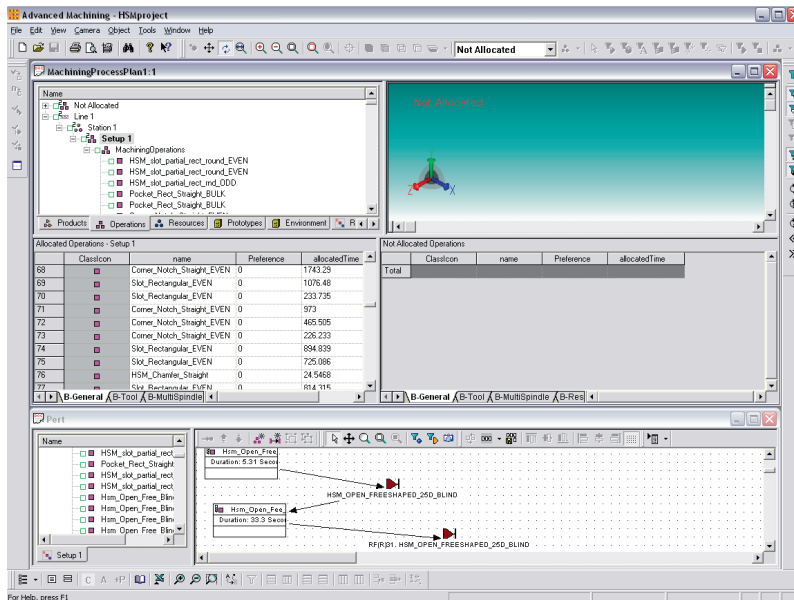

Figure 7.11: The operation sequencing environment: the line balancing view (top) and PERT view (bottom)

7.2 Practical usage and evaluation

During and after the project, Fokker Aerostructures has used and evaluated the developed process planning software. This section discusses their experiences and findings.

The initial intent of their evaluation was to perform process planning on parts of increasing complexity, starting with a simple one, so it could be analysed what issues and situations pose difficulties for the software. Unfortunately, and partially due to IT infrastructure problems, this evaluation has remained limited. Performance issues at the time in *Advanced Machining*, the application base of the pilot implementation, didn't help either.² They used the software for ten different parts, of which five were actual production models.

Their experiences with the general workflow as outlined in section 5.1 were as follows. Stiffness feature recognition generally produced good results, although it often required some user intervention. This indicates that the recognition algorithms should be improved; pattern recognition was fine but parameter extraction was not good enough, giving rise to quite laborious editing.

Creation and population of a set-up was almost all existing *eMPOWER Advanced Machining* functionality and didn't pose any problems.

Manual connection determination was also not a problem, although the automatic determination from the first prototype would have been convenient. Subsequent sequencing of stiffness features gave good results, although reviewing and editing was considered inconvenient.

Machining feature determination for stiffness features produced results that were good in the sense that the step strategy based knowledge was properly applied. Flaws were that the knowledge complexity pushed the knowledge reasoning engine to its limits, and that resulting machining features could have been wider, to avoid small operations later. This step properly laid down the machining sequence for a wall. On the other hand, the knowledge did not consider all details that can occur in industrial products. In addition, generally intersection of stiffness features (walls) implies intersection of their machining features, and feature intersections occur regularly due to the nature of the parts. This means that many machining features require adaptation.

A core step in the adaptation of machining features is the automatic handling of machining feature interferences. It helps preventing remachining of part geometry. Resolving such interferences could be performed globally, for the whole part, but also locally, for a user-determined subset of machining features. The many intersections and details discussed above, however, often resulted in irregularly shaped 2.5D or 3D features. How to resolve an interference was automatic rather than interactive, which made the results less predictable, or rather, less controllable by a user. Relatively slow performance and the absence of undo functionality in the early test versions used by Fokker Aerostructures

²In later versions of *Advanced Machining*, a caching mechanism was added, which significantly improved performance. This also enabled introducing a general undo/redo mechanism, which is available for about 95% of all commands.

also made it difficult to take full advantage of this functionality.

Computing of operations suffered from the limited implementation in that area, for example the operation method selection knowledge was incomplete. The developed dedicated tool path algorithm described in section 6.3.2 generally performed properly, and produced results as desired. However, that algorithm was aimed at and applied for open profile features. Knowledge rules for closed profile features were limited in number and didn't have the full benefit of a dedicated tool path algorithm. A 3D tool path processor was attached to irregular 3D features (which were a single type). These produced good results in terms of following and avoiding the three-dimensional product geometry within the boundary of the feature, but the tool paths did not have the domain-specific adaptations and controls provided by the dedicated 2.5D algorithm.

Generally speaking, the automatic tasks described above, most of them knowledge-based, each automate over 50% for the cases they are given, but none of them achieve 100% automation. These are tasks that depend on each other's results, so this lack of automation adds up as process planning progresses. Reviewing and adapting the results is thus necessary. This situation leaves a process planner with making a choice each time of where to make the changes in a process plan; on the level of stiffness features and their relations, in (sets of) machining features and their sequence constraints, or in the final tool paths? Clearly, editing on the level of stiffness features or machining features has the most influence on the stiffness-based strategies. Edits on those levels can make or break proper application of such a strategy. Because these were considered important, this made a process planner hesitant; one felt one didn't have a full grasp of the consequences of applied changes. It should be noted that similar behaviour can be observed for traditional computer-aided process planning systems. When process planners are used to working and intervening on the level of tool paths, they need to grow into working with a system where they can also work on a higher level, i.e. with features. Users need to develop a feeling for deciding which issues should be dealt with on which level.

The main gap was between the initial (knowledge-based determined) set of machining features, and the operations. Apart from the absence of a domain-specific tool path algorithm for 2.5D closed profile features, knowledge and editing tools were focussed on working with or towards more specific (parametric) feature types rather than more generally shaped ones. With models from industrial practice, this forces process planners into editing. Focussing more on (2.5D or 3D) free-shaped features, from stiffness features to machining features to operations, would have been more suited to such models. It could have helped increasing the level of automation without compromising the general approach.

The available reviewing and editing tools were limited, because *Advanced Machining* as an application focusses more on automation than on editing. Although these tools improved and increased over time (*Advanced Machining* itself was also still much in development at the time), feature editing was considered relatively laborious. Especially because of the large number of machining features, functionality was desired such as easy combining of machining features into one for efficiency (in a way easier than sketching),

or group-wise editing of machining features instead of one by one. Presentation (viewing) of the data was generally conceived well. Showing the machining features' volumes around a wall gives a planner an immediate idea of how - in which steps - the geometry will be manufactured, even without the exact sequence. Still, sequence constraint reviewing was considered difficult. Editing was found laborious, and reviewing lacked ways to get a good overall overview, like a tree order, network presentation or a sequence simulation. The feature sequence viewing commands were considered useful, but insufficient. Operation (tool path) editing was acceptable, but did suffer from 'growing pains' in the application base. Finally, operation knowledge editing was also considered a difficult task.

Overall, the assessment of Fokker Aerostructures was that the concepts and approaches for handling thin-walled geometry were adequate and the knowledge-based automated process planning tasks useful. The general concepts of stiffness features, machining features, feature sequences, mixed mode operations and knowledge-based strategies to apply the step approach were considered comprehensible for process planners, as well as the different responsibilities (scopes) of the different tasks. Features were not only seen as a vehicle to apply the proper knowledge, but also improved the overview over a process plan, despite the limited options to review feature sequences. When other users see a process plan, one in terms of features will be easier to read than one expressed in terms of tool paths. The most beneficial advantage of the software was the automated application of stiffness-based knowledge, especially in the sense that the software determined *when* something should be machined.

Fokker Aerostructures' original planning software tools didn't and don't have any stiffness-based tools to aid them in their task. The level of automation in those tools has improved since the start of this project in the sense that tool path calculation has been automated more. However, Fokker Aerostructures feel they have too little direct control over these tool paths, and that the automatic proposal tends to re-machine product geometry too often; in other words, they still need to intervene often with manual corrections. It doesn't offer the level of control provided by the tool path algorithm developed for this project. On the other hand, what this software lacks in automation, it makes up for in editing possibilities. For the application area, however, it still lacks proper support.

Despite the advantages, acceptance of the project's software suffered from a lack of maturity; incompleteness of the implementation. Summarising earlier criticism, feature manufacturing knowledge was correct but not complete enough for parts from industrial practice. It was felt that, had knowledge been expressed for more generalised (free-shaped) features, the level of automation could have improved considerably. Similarly, tool path algorithms for closed profile features and 3D tool path algorithms dedicated to thin wall machining would have aided in this. Lack of automation makes editing possibilities more important, and the offered reviewing and editing tools were too limited (not convenient enough) for the high extent of their use. The current software means made that a process planner needs to be very familiar with these means (implemented manufacturing knowledge, working of the software) to come to a good end result, rather than that it helped users in the right direction. All together, the labor-intensiveness

of the process planning, because of too many exceptional situations, made that the software as-is did not result in faster process planning as before. This and the immature state of the software made Fokker Aerostructures decide that, despite its advantages and benefits such as consistent enforcement of proper manufacturing strategies, it was not ready for practical (production) deployment.

Chapter 8

Advances in thin wall manufacturing

To put the work described in this thesis in perspective, this chapter presents a discussion of more recent research in the application area. A look at more recent literature shows that there is an increasing interest in machining of thin-walled products, in the sense that more researchers devote their attention to it, and in previously uncultivated directions.

8.1 Machining of thin-walled parts

A lot of recent high-speed machining literature that doesn't consider thin walls, focusses on chatter. Already in 2000, a piece of discussion from [Davies & Balachandran 2000] did shed some light on this focus. "Chatter arises from two primary sources: (1) regenerative instabilities that result from the overcutting of a previously cut surface; and (2) driven oscillations that arise from the intermittent engagement between the workpiece and the tool. ... The second source of instability becomes important in peripheral milling operations where the radial immersion of the cutting is a small percentage of the cutter radius and therefore the workpiece and tool spend much of their time disengaged". This latter situation - low radial immersion - is a commonly used cutting condition in high-speed milling. Moreover, it is often recommended. With in addition "the tendency of the high-spindle rotation frequencies to interact with the resonances of the tools and/or workpiece" [Davies & Balachandran 2000], we can say this way of working is chatter-prone, making chatter indeed a problem to address.

The direction that research has taken for high-speed machining of thin-walled products was on one hand to be expected, on the other hand, it is surprising. Namely, the solution direction for occurring problems is typically sought in cutting conditions.

The obvious difficulty in all of this research is that each tries to predict the effect that cutting conditions will have on thin workpieces, and even more that this workpiece is constantly changing. Or, as put by Ratchev et al., "There is still a knowledge gap in identifying the impact of deflection on the process of metal removal and hence there is a lack of systematic approaches to modelling, prediction and compensation of the component errors due to force-induced deflection in thin-walled structures" [Ratchev et al. 2006a].

Nevertheless, Ratchev et al. present in [Ratchev et al. 2006a] and [Ratchev et al. 2006b] an offline error compensation approach; an approach that iteratively predicts workpiece deflection using finite element analysis and adapts the tool path geometry to compensate the error, until the error is within tolerance. One can see how this tends to become computationally intensive quickly, meaning practical usage would be best feasible where situations (in terms of workpiece geometry) can be simplified into standard, straightforward cases.

Others address chatter. [Davies & Balachandran 2000] focus on the influence of impact dynamics, which they say dominate vibrations in milling where the cutter rotation can excite flexible workpiece modes. According to them, because of the low radial immersion, "the intermittent engagement introduces a nonlinearity similar to that experienced in impact oscillator problems." With their model, where the workpiece is modelled as a cantilever plate, they can explain part of the complex behavior from their experiments. Differences between model and experiments were thought to be due to facts that they considered only one dynamic workpiece mode, and that they didn't consider the effect of the changing workpiece surface. In other words, their model was not yet complete enough.

Bravo et al. expand on the stability lobe concept. They state that in cases where the machine structure and the machined workpiece have similar dynamic behaviour, the relative movement of the two should be considered. Such a model is different and more accurate than superposition of machine and workpiece lobe diagrams, and often predicts lower stable depths of cut. They add a third dimension (axis) to stability lobe diagrams, namely the geometric state of the workpiece. They based the workpiece's dynamic behaviour on impact tests on different discrete workpiece states. They also point out that from a chatter point of view, workpiece modes where only a thin wall portion vibrates - which generally have a low natural frequency - are not relevant because they do not cause displacement at the point where the tool is machining. [Bravo et al. 2005]. From a vibration remachining point of view, however, these modes can still be a problem.

Atlar et al. also address dynamics of machining a changing thin-walled workpiece. They use finite element analysis to calculate the frequency response of the workpiece at different states. They try to capture the change in structure, in terms of mass, stiffness and damping, in modification matrices, and update the workpiece's frequency response at every machining step, in an attempt to improve predictability of this behavior. Their results show that both depths of cut and frequencies associated with stability lobes change, and lobes can even disappear, as the workpiece becomes thinner. They also show that, based on the results of their models, there is a lot of time to gain when variable depths of cut are used when peripheral milling a thin wall in separate operations. Using the maximum possible depth of cut per pass will be more effective than using the maximum depth of cut for an operation (the minimum of maxima for a set of passes). They also show that when using combined finishing and roughing, i.e. a step-wise approach, that (a) this difference in efficiency is virtually absent and (b) it is much faster - about 5 times in their case - than separate finishing and roughing. This is due to the increased rigidity of the workpiece during machining, and it shows the importance of cutting strategies. [Atlar et al. 2008]

Seguy et al. discuss surface roughness variation in thin wall milling. They address the phenomenon that on the same part, different surface roughness are shown, although the cutting conditions and the dynamic characteristics are constant. The model in the article concerns finishing and therefore considers the workpiece geometry constant. This numerical model for obtaining vibration amplitudes uses characteristics the authors consider indispensable for a thin wall milling model: the regenerative effect of the cut, the modal shape, the fact that the tool may leave the cut when vibrations are too strong, and the ploughing effect: due to workpiece vibrations, the clearance face of the tool is in contact with the material, and increases process damping. The explanation they propose for the surface roughness variations along a wall, is the modal shape of the wall's vibration mode that was hit. Vibration in an anti-node of the shape causes a rougher surface. Modes with anti-nodes at the point of machining tend to prevail. Despite the strong relationship they see between surface roughness and vibration amplitude, they find this link too complex to give predictive values. [Seguy et al. 2008]

Rai & Xirouchakis note that literature on thin wall machining often consider only parts with simple geometry, and state that despite the research in this area, there is still lack of a comprehensive model for determining the final part's quality, by taking into account process planning parameters like fixtures, operation sequence, tool paths and cutting variables. They developed a FEM based milling simulation package for three-dimensional prismatic workpieces, that can work with APT files. Workpiece vibrations are not incorporated, but it does consider cutting force, workpiece temperature distribution, part deflection and stresses (apparently even initial stresses) and fixture-workpiece flexible contacts. They claimed good agreement with real field data. [Rai & Xirouchakis 2008]

Although these developments in the field of cutting conditions are promising, they still seem to be too much still under development to become part of a process planning system. Much research is still aimed at properly predicting the result of cutting conditions. Several of the above articles note the difficult feasibility of good predictions, and, as noted in [Rai & Xirouchakis 2008], a comprehensive model considering all relevant phenomena is not yet available. Also, there is need for a certain degree of reliability of an approach. The subject matter is complex, and research in this area is still young. The nature of these approaches - their focus on cutting conditions, and the fact that the workpiece's geometry is considered to be fully known - makes them future candidates to become part of a cutting conditions engine. In this sense, as they mature, they can become a valuable addition to the process planning automation as described in this thesis. For practical usability, however, simplification may be necessary, in the sense that only a local wall is considered rather than the entire product, or a simplification of that wall, to simplify calculations. The complexity of the subject matter makes the validity of such a simplification a topic to address before applying it.

Nevertheless, and certainly until predictive cutting condition models achieve a sufficient level of reliability and maturity, it is better to base process planning for thin-walled parts on an error avoidance approach than on an error compensation approach.

8.2 Process planning for high-speed machining and thin-walled parts

Schützer et al. start their article [Schützer et al. 2007] by quoting a survey, that states that the NC-programming time for high-speed machining usually surmounts the machining time by factor 2 to 3. They state that beside optimisation of tool path generation algorithms, automation of the NC programming process should also be a target for CAM systems. Their article presents a prototype of a knowledge based, feature oriented CAM system for free form surface models for high-speed machining. Curvature of the free form features is essential for the automatic selection of a strategy. For example, a planar face results in a two axes operation, and for a free form feature with slight convex curvature, five axes machining should be used. The machining type becomes an attribute of the feature. The software can choose technological parameters (tools, cutting parameters) depending on the feature, part material and machining operation. How the manufacturing features are extracted from the geometry and how knowledge is expressed in the system is not discussed in the article.

More aimed at thin-walled parts are the process planning support functions of Harik et al. [Harik et al. 2006]. They explicitly renounce the idea of complete automation of process planning. The support functions are:

- Providing a list of compatible machine-tools, considering the part dimensions (or rather, the minimal stock).
- Tool selection for finishing, based on geometry constraints. Based on a set of faces and a direction, tool diameter and corner radius are based on radii in the part geometry, for example.
- They suggest an order for machining thin walls if their sides require different machining (peripheral vs. end milling) due to the cutting force directions.
- Analysis from an accessibility viewpoint of whether faces can be end milled, and if partially, which area of it, based on geometric boolean operations.
- Suggestion of a machining direction for surfaces to be milled peripherally, based on among other things accessibility (edge convexity, visibility).
- Suggestion of a general orientation of the part in a setup, based on the largest set of parallel faces that can be machined using end milling.

Yu et al. [Yu et al. 2008] propose a slicing based feature recognition approach to support layer by layer machining that is often applied for thin-walled parts. Assuming that the general machining direction of the part is known, they slice part and blank with a plane perpendicular to that direction. They try to combine the resulting intersection curves of subsequent slices into general - not purely prismatic - pockets and 'auxiliary' features like ribs or islands. They conclude, "Information about machining

features such as tops, bottoms, guides, and so on, can be directly used to compute a tool path, well solving the problem of automatic setting machining geometry in NC programming." Whether layer (or slice) specific information is passed on from a feature to use in an operation, is not fully clear, but seems logical.

So computer aided process planning for the application area is also receiving more research attention recently. In the discussed tools for thin-walled parts, however, there seems to be limited explicit reasoning with stiffness issues. The drawback of [Harik et al. 2006] is that it is aimed at aid (automation or advice) for specific subtasks rather than workflow automation. The real decisions are left to the user. Also, most of the presented utilities are not especially aimed at issues specific for thin wall machining. [Yu et al. 2008] is more aimed at automation, but presumes a layer based machining approach.

All in all, most attention in research on thin wall manufacturing is still aimed on the level of tool paths and cutting conditions. Models in this area for thin wall machining are explicitly reasoning with the flexibility of the workpiece, and becoming increasingly interesting for computer aided process planning. On the other hand, research in computer aided process planning for the application area still remains limited and hardly seems to offer automation based on explicit stiffness-based reasoning.

Chapter 9

Conclusions

This chapter discusses the conclusions of the research for this project, as well as the recommendations flowing from it.

9.1 Conclusions

Technological developments have made high-speed machining economically attractive. It is now a manufacturing technology that can competitively manufacture thin-walled parts. Thin-walled parts however require a lot of material to be machined, and with high-speed machining, this takes a lot of tool paths. Process planning such products is difficult due to the vast amount of paths to program and the low stiffness of the final part.

The most important characteristic of process planning of thin-walled parts, is that at one point in time, the workpiece becomes the weakest element during machining. This is where the application domain distinguishes itself from traditional machining. In addition to the workpiece becoming the weakest element, relevant characteristics like stiffness change significantly during manufacturing. This thesis does not consider initial workpiece stresses and product warpage that might result from it. Its focus is more on effects induced by the machining process and the planning that affect part accuracy. Nonetheless, the constantly changing properties of the weakening workpiece make it difficult, if not impossible, to guarantee a sufficiently accurate result by means of process parameters (which is a common method of approach in machining). What became apparent fairly quickly, also from operating procedures at Fokker Aerostructures, was that stabilisation was to be sought in the workpiece itself. The limited relevant literature in the field confirmed this. Stabilising support at the point, both in time and place, of machining forms the essence for dealing with workpiece deflections. And preferably, this support is provided by the workpiece itself, by remaining, unmachined material. Realising this support each time in the places and times when and where it is needed, is not straightforward, especially when a part is (almost) completely thin-walled. This can only be achieved by careful planning. Process planning software for

this application area must provide the proper means for this.

Because lack of stiffness is the major concern, it is more or less logical to view a workpiece in terms of stiffness. The thin-walled nature of the parts makes it far less possible to manufacture geometric shapes independently. Feature technology is a key to automation, especially in process planning. It provides the possibility to define manageable, recognisable portions of knowledge, which can be used to obtain recognisable results. This research has attempted to extend research on feature-based and knowledge-based process planning of the Design, Production and Management research group into this new application area. This work intentionally tries to remain close to process planners:

- The existing common concepts of machining features and operations related to them have been left intact. These are mostly employed for dealing with aspects related to the milling process.
- New concepts, such as stiffness features, connections and feature sequence constraints, were presented to take on the problems introduced by the new application domain: the thin-walled nature of the workpiece and the stiffness issues that it entails.

In this way, different problem areas are separated for a large part, and by preserving existing concepts, process planning remains relatively familiar. In addition, it was attempted to make the new concepts simple and recognisable. Stiffness features typically reflect the way a process planner views thin-walled products. The step-wise strategy for these features, expressed in volumes, is also in line with practice and the way of thinking of a process planner. The multiple view problem in this application area is thus approached in a feature based manner; each view its own features and knowledge. An important purpose of separating these views, problems and solutions, as much as possible, was to reduce the complexity of the problem area. The chosen concepts made it possible to express and formalise domain knowledge at Fokker Aerostructures. The fact that such knowledge could be expressed in these terms, indicates that the concepts are suitable for the domain.

The support principle is the leading concept in this research and in the developed application. Stiffness issues are addressed through this principle by means of manufacturing strategies. This makes such strategies a core element of the process planning. On different levels (operations/toolpaths, features, whole part), this was detailed differently. The fact that different geometries can require different manufacturing strategies, from a stiffness point of view, bears similarity with determination of manufacturing methods in traditional CAPP, in which different geometries can also lead to different considerations. Many of the strategies are therefore applied based on knowledge rules. This offers the possibility of editing and extension, which is convenient in a time where the strategy knowledge is still accumulating and not yet standardised.

An important characteristic of all strategies is that, compared to traditional milling, they consider a larger environment. The focus is more on the material to remain than the material to remove. Operation knowledge considers roughing and finishing together.

Stiffness strategies consider multiple stiffness features and the network of physical connections between them. Even the setup is taken into consideration, because the workpiece's orientation in the setup is an important context. It determines how to interpret these connections and strongly affects how to manufacture the part. Considering a larger environment makes the strategies and the knowledge to apply more complex. This appears from the fact that existing process planning for these parts is more time-consuming than for non-thin parts, but also from the complexity of the knowledge implemented in the framework of this project, especially when it comes to determining machining features. Therefore, it becomes considerably more difficult to increase the level of automation. On the other hand, considering a larger context is a necessity for this application area. Process planning based on the support principle requires control over the whole workpiece (or large portions of it). To guarantee a certain level of support when machining a particular piece of geometry, the intermediate state of the workpiece at that point needs to be under control. Not necessarily exact physical intermediate states, but rather minimum demands on these intermediate states. Providing support locally can, depending on the part, pose demands globally, on the intermediate state of the workpiece as a whole. Traditional process planning, where the focus is more on efficiency and controlling the process, does not offer sufficient means for this.

The essence of this process planning approach, knowledge based reasoning together with the most relevant knowledge itself, has been successfully automated. Many steps that are functionally important, and important decisions for the application area, have been automated, which takes work out of the hands of a process planner. The chosen concepts have contributed to this. They also contributed to a better overview over the planning. In addition, a dedicated tool path algorithm was successfully developed, which addresses several thin wall machining demands, high-speed machining demands and wishes and optimisation considerations.

From evaluation of the resulting application for industrial practice, the automatic determination of the machining sequence for thin-walled geometry was considered the greatest benefit. It also showed that decomposition of knowledge into too specific feature types can be counterproductive, especially due to the commonness of feature intersections. For example, considering a piece of geometry as a free-shaped wall rather than a set of specific walls helps aligning machining feature geometry for that wall, and can also help reducing the complexity of the related knowledge. The feature types implemented for this project were in hindsight too specific. This hampered the automatic processing, thus increasing the interactive editing work for a process planner. The evaluation also underlined the importance of presentation. On one hand, the general overview on the process plan increased, due to the feature (volume) based presentation. On the other hand, an exact overview of the relations between features (connections, sequence constraints) was difficult to obtain with the provided visualisation means in the user interface.

9.2 Recommendations

The application that was developed within the framework of this thesis, is not yet mature enough to be fit for use as a commercial system. The software has been tested by Fokker Aerostructures, but as this company has been involved in its development, it becomes difficult to draw rigid conclusions about the practical value for other companies. This section discusses possible development directions to help the application mature, as well as suggestions for future research.

In the area of cutting conditions determination, this research has remained limited to prescripts for typically geometrical parameters. As section 8.1 shows, research in the area of cutting conditions for thin-wall machining has gained interest in the recent years. Although this research needs to mature, such models can be a useful supplement for the process planning software described in this thesis, especially if such a model considers all relevant phenomena. Moreover, the approach based on the support principle enable such models to work more effectively because it allows them to reason about relatively simple, more local geometry. The state of this research should be investigated more thoroughly, as well as the validity of considering only local and/or simplified geometry. This enquiry should focus on applicability of such models in computer aided process planning. Alternatively, and because predictive models are still in development, empirical cutting conditions data could be used. In that case, it seems logical that cutting condition data should be differentiated on the basis of, among other things, vulnerability of the geometry being machined for bending. Gathering and differentiating this data properly, however, can become a comprehensive and complex task. Both approaches, empirical model and calculation model, need information about the thin geometry to work with. So in both cases, more detailed information about thin geometry needs to be passed down to the level of operations and/or tool paths than is currently the case. This seems to reduce the separation of views discussed earlier. Still, it doesn't change the division of responsibilities - what problems are addressed where, on what level - because the cutting condition determination task still focusses on the effect of the machining process on accuracy on a local level.

A subset of the application design was implemented (see chapter 5 and 6), and the implemented knowledge was also limited. As noted in chapter 7, the application's level of automation needs further improvement. However, it must be avoided to increase the complexity of required knowledge rules or of application usage. Therefore, the use of more general - free-shaped - feature types, both as stiffness features and machining features, should be investigated further. This may even reduce the knowledge complexity. Following the domain-specific open profile tool path algorithm, development of tool path algorithms for 2.5D closed profile feature types and 3D feature types that comply with the requirements for thin-wall machining, will also help to increase the coverage level of the application.

The research and application development carried out for this project has predominantly focussed on technological aspects of process planning, because the main objective was automating process planning tasks. This has consequences for the possibilities for

user interaction with the software. It is difficult to determine on beforehand where a user needs and should be allowed to intervene. In this respect, prime areas of future attention are feature sequence presentation, especially for features, and feature editing support.

Finally, the implemented knowledge for determining machining features turned out to be quite complex, both for the reasoning engine and for users. With respect to the knowledge content, this is inherent to the application area, because of the dependencies between features (see chapter 4). It may be worthwhile to look into possibilities for reducing the complexity of the knowledge structure. This is in fact an implementation issue, because the knowledge content poses demands that the available knowledge engine was not built for. This forced the implementation of complex knowledge content into an even more complex knowledge structure. Attempts to reduce the complexity of the structure are likely to require adaptation of the knowledge reasoning engine.

Bibliography

- [Agba et al. 1999] Agba, E.I., Ishee, D. & Berry, J.T., "High speed machining of thin-walled structures", in: *3rd international machining and grinding conference (SME)*, Cincinnati, Ohio, 1999.
- [Alting & Zhang 1989] Alting, L. & Zhang, H., "Computer aided process planning: the state of the art survey", in: *International journal of production research*, vol. 27, n. 4, 1989, p. 553-585.
- [Altintas et al. 1992] Altintas, Y., Montgomery, D. & Budak, E., "Dynamic peripheral milling of flexible structures", in: *Journal of engineering for industry*, vol. 114, 1992, p. 137-145.
- [Andringa 2001a] Andringa, J.A., *High speed machining, The quest for control*, internship report, Enschede, 2001.
- [Andringa 2001b] Andringa, J.A., *Toolpath generation for high speed machining, Finding the right path (OPM-697)*, M.Sc. thesis, University of Twente, Enschede, 2001.
- [Atlar et al. 2008] Atlar, S., Budak, E. & Özgüven, H.N., "Modeling part dynamics and chatter stability in machining considering material removal", in: *Proceedings of 1st international conference on process machine interactions*, Hannover, Germany, 2008, p.61-72.
- [Beard 1997] Beard, T., "Programming for high-speed machining", in: *Modern Machine Shop Magazine*, vol. 70, n. 3, 1997, p. 104-108.
- [Boogert 1994] Boogert, R.M., *Tool management in computer aided process planning*, Ph.D. thesis, University of Twente, Enschede, 1994.
- [Bravo et al. 2005] Bravo, U., Altuzarra, O., & López de Lacalle, L.N., "Stability limits of milling considering the flexibility of the workpiece and the machine", in: *International journal of machine tools and manufacture*, vol. 45, n. 15, 2005, p. 1669-1680.
- [Chang et al. 1994] Chang, J.Y., Lai, G.J., & Chen, M.F., "A study of the chatter characteristics of the thin wall cylindrical workpiece", in: *International journal of machine tools and manufacture*, vol. 34, n. 4, 1994, p. 489-498.

- [Choi et al. 1984] Choi, B.K., Barash, M.M. & Anderson, D.C., "Automatic recognition of machined surfaces from a 3D solid model", in: *Computer-aided design*, vol. 16, n. 2, 1984, p. 81-86.
- [Choi et al. 1997] Choi, B.K., Kim, D.H. & Jerard, R.B., "C-space approach to tool-path generation for die and mould machining", in: *Computer-aided design*, vol. 29, n. 9, 1997, p. 657-669.
- [CNC Software Inc] <http://www.mastercam.com/>
- [Davies & Balachandran 2000] Davies, M.A. & Balachandran, B., "Impact dynamics in milling of thin-walled structures", in: *Nonlinear dynamics*, vol. 22, n. 4, 2000, p. 375-392.
- [DelCAM] <http://www.delcam.com/powermill/powermill.htm>
- [Elbestawi & Sagherian 1991] Elbestawi, M.A. & Sagherian, R., "Dynamic modelling for the prediction of surface errors in the milling of thin-walled sections", in: *Journal of materials processing technology*, vol. 25, 1991, p. 215-228.
- [ElMaraghy 1993] ElMaraghy, H.A., "Evolution and future perspectives of CAPP", in: *CIRP Annals*, vol. 42, n. 2, 1993, p. 739-751.
- [Erve 1988] Erve, A.H. van 't, *Generative computer aided process planning for part manufacturing, an expert system approach*, Ph.D. thesis, University of Twente, Enschede, 1988.
- [Fokker Aerostructures 2003] Salomons, R., *Testresultaten removal features* (in Dutch), internal reports, Fokker Aerostructures, Hoogeveen, 2003.
- [Geelink 1996] Geelink, R., *Flexible definition of form features*, Ph.D. thesis, University of Twente, Enschede, 1996.
- [Hagen 2004] Hagen, G.A., *Operations for high-speed milling of thin-walled structures, Methods, tool paths and optimization in computer aided process planning (OPM-736)*, M.Sc. thesis, University of Twente, Enschede, 2004.
- [Han 1996] Han, J., "Survey of feature research", Technical report IRIS-96-346, Institute for robotics and intelligent systems, University of Southern California, 1996.
- [Han et al. 2000] Han, J., Pratt, M. & Regli, W.C., "Manufacturing feature recognition from solid models: A status report", in: *IEEE transactions on robotics and automation*, vol. 16, n. 6, 2000, p. 782-796.
- [Hanita] Hanita, *High speed machining tips*, http://www.hanita.com/hanita_protected/tec00011.htm
- [Harik et al. 2006] Harik, R., Capponi, V., Lombard, M. & Ris, G., "Enhanced functions supporting process planning for aircraft structural parts", in: *IMACS multiconference on computational engineering in systems applications*, vol. 2, 2006, p. 1259-1266.

- [Henderson & Anderson 1984] Henderson, M.R. & Anderson, D.C., "Computer recognition and extraction of form features: a CAD/CAM link", in: *Computers in industry*, vol. 5, n. 4, 1984, p. 329-339.
- [Houten 1991] Houten, F.J.A.M. van, *PART, a computer aided process planning system*, Ph.D. thesis, University of Twente, Enschede, 1991.
- [Hurk 1998] Hurk, P. van den, "Het hogesnelheidsverspanen van aluminium" (in Dutch), in: *MB Produktietechniek*, vol. 64, n. 1/2, 1998, p. 10-15.
- [ISO 1983] ISO 1101: *Technical drawings - Geometrical tolerancing - Tolerancing of form, orientation, location and runout - Generalities, definitions, symbols, indications on drawings*, 1983.
- [Jablonowski 1990] Jablonowski, J., "The technology of the future is now the present: Perspective on high speed machining (keynote address)", in: Schneider, G. Jr. (ed.), *High speed machining, solutions for productivity, Proceedings of the SCTE 1989 conference*, ASM International, Ohio, 1990, p. 1-4.
- [Juneja & Sekhon 1987] Juneja, B.L. & Sekhon, G.S., *Fundamentals of metal cutting and machine tools*, John Wiley & Sons, New York, 1987.
- [Kaldos et al. 1996] Kaldos, A., Dagiloke, I.F. & Boyle, A., "Computer aided cutting process parameter selection for high speed milling", in: *Journal of materials processing technology*, vol. 61, 1996, p. 219-224.
- [Kals et al. 1990] Kals, H.J.J., Houten, F.J.A.M. van & Tiemersma, J.J., "CIM in small batch part manufacturing", in: *22nd CIRP international seminar on manufacturing systems*, University of Twente, Enschede, 1990.
- [Kals 1991] Kals, H.J.J., *Trillingen en stabiliteit van de verspanende bewerking* (in Dutch), University of Twente, Enschede, 1991.
- [Kals et al. 1994] Kals, H.J.J., Powell, P.C., Houten, F.J.A.M. van & Ponsen, J.M., *Produktiesystemen II* (in Dutch), University of Twente, Enschede, 1994.
- [King 1985] King, R.I. (ed.), *Handbook of high-speed machining technology*, Chapman & Hall, New York, 1985.
- [Kline et al. 1982] Kline, W.A., DeVor, R.E. & Shareef, I.A., "The prediction of surface accuracy in end milling", in: *Journal of engineering for industry*, vol. 104, 1982, p. 272-278.
- [Korte 1998] Korte, D.J. de, "Wat is nu eigenlijk hogesnelheidsverspaning?" (in Dutch), in: *MB Produktietechniek*, vol. 64, n.11/12, 1998, p. 328.
- [Mäntylä et al. 1996] Mäntylä, M., Nau, D. & Shah, J.J., "Challenges in feature-based manufacturing research", in: *Communications of the ACM*, vol. 39, n. 2, 1996, p. 77-85.

- [Marusich & Askari 2001] Marusich, T. D. & Askari, E. , "Modeling residual stress and workpiece quality in machined surfaces", in: *Proceedings of the 4th CIRP international workshop on modeling of machining operations*, 2001, p. 105-109.
- [MMSonline] <http://www.mmsonline.com/hsm/>
- [MMSonline a] MMSonline, "Die/mold - Programming - Ramp in", in *High speed machining electronic supplement* (<http://www.mmsonline.com/hsm/>).
- [MMSonline b] MMSonline, "Die/mold - Programming - Trochoidal milling", in *High speed machining electronic supplement* (<http://www.mmsonline.com/hsm/>).
- [MMSonline c] MMSonline, "Aerospace - Programming - Feed rate optimisation", *High speed machining electronic supplement* (<http://www.mmsonline.com/hsm/>).
- [MMSonline d] MMSonline, "Aerospace - Programming - Thin walls - Incremental pocketing", *High speed machining electronic supplement* (<http://www.mmsonline.com/hsm/>).
- [Monreal & Rodriguez 2003] Monreal, M. & Rodriguez, C.A., "Influence of tool path strategy on the cycle time of high-speed milling", in: *Computer-aided design*, vol. 35, n. 4, 2003, p. 395-401.
- [NCGraphics 1999] <http://www.ncgraphics.co.uk/products/machiningstrategist/>
- [OpenMind 1999] OPEN MIND Software Technologies GmbH, <http://www.openmind.de/>, 1999.
- [Ouwerkerk 2003] Ouwerkerk, G. van, *Removal feature determination, For use in CAPP for high-speed milling of thin-walled products (OPM-719)*, M.Sc. thesis, University of Twente, Enschede, 2003.
- [Popma 2000] Popma, M.G.R., *High speed milling literature survey (OPM-660)*, internal report, University of Twente, Enschede, 2000.
- [Post 2001] Post, M.K., *Feature recognition of thin walled products, An implementation of the feature recognition algorithms for thin bodies in eMPower Machining*, internship report, Enschede, 2001.
- [Rai & Xirouchakis 2008] Rai, J.K. & Xirouchakis, P., "Finite element method based machining simulation environment for analyzing part errors induced during milling of thin-walled components", in: *International journal of machine tools and manufacture*, vol. 48 n. 6, 2008, p. 629-643.
- [Ratchev et al. 2006a] Ratchev, S., Liu, S., Huang, W., & Becker, A.A., "An advanced FEA based force induced error compensation strategy in milling", in: *International journal of machine tools and manufacture*, vol. 46, n. 5, 2006, p. 542-551.

- [Ratchev et al. 2006b] Ratchev, S., Liu, S., Huang, W., & Becker, A.A., "An advanced machining simulation environment employing workpiece structural analysis", in: *Journal of achievements in materials and manufacturing engineering*, vol. 16, n. 1-2, 2006, p. 139-144.
- [Salomons 1995] Salomons, O.W., *Computer support in the design of mechanical products, Constraint specification and satisfaction in feature based design for manufacturing*, Ph.D. thesis, University of Twente, Enschede, 1995.
- [Sandvik 2003] Sandvik, *Application guide, Aerospace frames*, Sandvik Coromant, Sandviken, 2003.
- [Schulz & Kaufeld 1988] Schulz, H. & Kaufeld, M., "Hochgeschwindigkeitsfräsen von Leichtmetallguß- Kräfte, Spanbildung, Leistungsbedarf und spezifisches Spannungsvolumen" (in German), in: *Werkstatt und Betrieb*, vol. 121, n. 3, 1988, p. 217-222.
- [Schulz & Spur 1989] Schulz, H. & Spur, G., "Aspects of cutting mechanisms in high speed cutting", in: *CIRP Annals*, vol. 38, n. 1, 1989, p. 51-54.
- [Schulz & Moriwaki 1992] Schulz, H. & Moriwaki, T., "High-speed machining", in: *CIRP Annals*, vol. 41, n. 2, 1992, p.637-643.
- [Schulz 1999] Schulz, H., "The history of high-speed machining", in: *Proceedings of the 5th international scientific conference on production engineering (CIM 99)*, 1999, p. 0-001.
- [Schulz et al. 2001] Schulz, H., Abele, E. & Sahm, A., "Material aspects of chip formation in HSC machining", in: *CIRP Annals*, vol. 50, n. 1, 2001, p. 45-48.
- [Schützer et al. 2007] Schützer, K., Abele, E., Stroh, C. & Gyldenfeldt, C. von, "Using advanced CAM-systems for optimized HSC-machining of complex free form surfaces", in: *Journal of the Brazilian society of mechanical sciences and engineering*, vol. 29, n. 3, 2007, p. 313-316.
- [Seguy et al. 2008] Seguy, S., Dessein, G. & Arnaud, L., "Surface roughness variation of thin wall milling, related to modal interactions", in: *International journal of machine tools and manufacture*, vol. 48, n. 3-4, 2008, p. 261-274.
- [Shah et al. 1991] Shah, J.J., Sreevalsan, P. & Mathew, A., "Survey of CAD/feature-based process planning and NC programming techniques", in: *Computer-aided engineering journal*, vol. 8, n. 1, 1991, p. 25-33.
- [Siemens PLM Software 2009] Siemens Product Lifecycle Management Software Inc., *Tecnomatix Machining Line Planner fact sheet*, http://www.plm.automation.siemens.com/de_ch/Images/16796_tcm782-82692.pdf, 2009.
- [Smith et al. 1991] Smith, S., Cheng, E. & Zamudio, C., "Computer-aided generation of optimum chatter-free pockets", in: *Journal of materials processing technology*, vol. 28 n. 1-2, 1991, p. 275-283.

- [Smith & Dvorak 1998] Smith, S. & Dvorak, D., "Tool path strategies for high speed milling of aluminium workpieces with thin webs", in: *Mechatronics*, vol. 8, 1998, p. 291-300.
- [Streppel 1983] Streppel, A.H., *Verspanende bewerkingen, systeembeschouwing, frezen* (in Dutch), University of Twente, Enschede, 1983.
- [Sutherland & DeVor 1986] Sutherland, J.W. & DeVor, R.E., "An improved method for cutting force and surface error prediction in flexible end milling systems", in: *Journal of engineering for industry*, vol. 108, 1986, p. 269-279.
- [Terasaki 1996] Terasaki, T., *Our approach to high-precision, high-efficiency die machining and the use of our CAM-TOOL system to improve it*, <http://www.graphicproducts.co.jp/english/news/phil.htm>, 1996.
- [Timoshenko et al. 1959] Timoshenko, S.P. & Woinowsky-Krieger, S. *Theory of plates and shells*, McGraw-Hill, New York, 1959.
- [Tlusty & Zaton 1983] Tlusty, J. & Zaton, W., "Stability lobes in milling", in: *CIRP Annals*, vol. 32, n. 1, 1983, p. 309-313.
- [Tlusty 1986] Tlusty, J., "Dynamics of high-speed milling", in: *Journal of engineering for industry*, vol. 108, 1986, p. 59-67.
- [Tlusty et al. 1990] Tlusty, J., Smith, S. & Zamudio, C., "New NC routines for quality in milling", in: *CIRP Annals*, vol. 39, n. 1, 1990, p. 517-521.
- [Tlusty 1993] Tlusty, J., "High-speed machining", in: *CIRP Annals*, vol. 42, n. 2, 1993, p. 733-738.
- [Tlusty et al. 1996] Tlusty, J., Smith, S. & Winfough, W.R., "Techniques for the use of long slender end mills in high-speed milling", in: *CIRP Annals*, vol. 45, n. 1, 1996, p. 393-396.
- [Weck et al. 1994] Weck, M., Altintas, Y. & Beer, C., "CAD assisted chatter-free tool path generation in milling", in: *International journal of machine tools and manufacture*, vol. 34, n. 6, 1994, p. 879-891.
- [Yu et al. 2008] Yu, F., Du, B., Ren, W., Zheng, G. & Chu, H., "Slicing recognition of aircraft integral panel generalized pocket", in: *Chinese journal of aeronautics*, vol. 21, n. 6, 2008, p. 585-592.
- [Zander 1998] Zander, R., "Hogesnelheidsverspanen" (in Dutch), in: *MB Produktietechniek*, vol. 64, n. 11/12, 1998, p. 342-360.
- [Zelinski 2005] Zelinski, P., "Chatter control for the rest of us", in: *Modern Machine Shop Magazine*, vol. 78, n. 5, 2005, p. 66-75.

Appendix A

Machining feature sizing

This appendix is a supplement to the machining feature size model described in section 4.1.2. Section A.1 provides a condensed record of milling tests that Fokker Aerostructures has performed, with as goal to tune the size model. Section A.2 describes the quantification of size model parameters.

A.1 Milling tests

Fokker Aerostructures has carried out tests on wall milling, to help quantify the size model described in section 4.1.2. They analysed the results; test figures and comments have been taken directly from their test reports [Fokker Aerostructures 2003]. As noted in section 4.1.2, they take the problem of vibration re-machining very seriously. Therefore, test results were also judged on the occurrence of this phenomenon. If possible, removal features should not only prevent excessive bending inaccuracies, but also inaccuracies due to this re-machining.

All tested walls are loose ribs. The tests use peripheral milling, generally using a 20 mm diameter tool for the large machining features and a 12 mm diameter tool for the small machining features, unless noted differently. The denoted wall sizes are length * thickness * height.

Table A.1 shows the meaning and unit of the short notations used in the test descriptions.

Tests wall of sizes 120 * 1 * 48

TEST1-0398-1A

Tools:

7033020 Dia 20 Lu=54 S25000 F11000 (0.22/t), features 1, 2, 5 & 6 (pre-work)

Short notation	Meaning	Unit
Dia	tool diameter	mm
Lu	tool stick-out length	mm
S	spindle speed	rpm
F (./t)	feed rate (resp. feed per tooth)	mm/min (resp. mm)
a_p	depth of cut	mm
B_{RF}	machining feature width	mm
h or h_{RF}	small machining feature height	mm
H or H_{RF}	large machining feature height	mm
B_{SF}	wall stiffness feature thickness	mm
L_{SF}	wall stiffness feature length	mm
H_{SF}	wall stiffness feature height	mm

Table A.1: Parameter abbreviations and units; for feature sizes, see also figure 4.3.

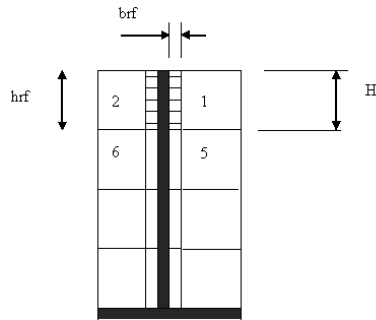

Figure A.1: Test 1-0398-1A

7033009 Dia 12 Lu=75 S22000 F5280 (0.12/t)

a_p 3 mm

$B_{RF} = 2$ mm, $h_{RF} = 12$ mm, $H_{RF} = 12$ mm

After the first cuts vibration occurred on both sides with a diameter 12 mill.

Reduced speed and feed (Speed to 18000, feed to 80 % of 5280).

The cutting length of the mill was 14 mm.

On the small machining feature side, vibration re-machining occurred on the wall top.

TEST2-0398-1A

As the previous test, but the cutting length of the mill was 12 mm.

On the small machining feature side, vibration re-machining occurred on the wall top every now and then.

TEST2-0398-2A

As the previous test, but the depth of cut used was 4 mm instead of 3 mm.
On the small machining feature side, vibration re-machining occurred on the wall top every now and then, more often than in the previous test.

TEST3-0398-3A

As the previous test, but the depth of cut was reduced to 1.5 mm.
Vibration re-machining on the wall top (on the small machining feature side) occurred far less, but the results were not quite satisfactory.

TEST4-0398-4A

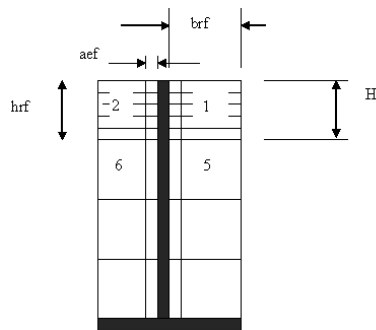

Figure A.2: Test 4-0398-4A

As the previous test, but B_{RF} was set to 11 mm (instead of 2 mm); the width of cut of the wall finishing pass (a_{ef}) is 2 mm.
Vibration re-machining did not occur, result was good.

TEST6-0398-6A

$B_{RF} = 11$ mm, $h_{RF} = 12$ mm, $H_{RF} = 48$ mm, $a_{ef} = 2$ mm

Differences with previous test:

- cutting length of the diameter 12 mill was 13 mm
- the large machining feature height H_{RF} was 48 mm instead of 12 mm (4 times as large)

Results were satisfactory.

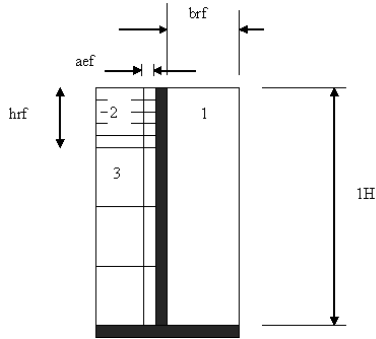

Figure A.3: Test 6-0398-6A

TEST7-0398-7A

As the previous test, but the depth of cut was increased to 2 mm.

Results were reasonable to good. Some vibration occurred at the end of the rib. The 12 mm mill started vibrating a little at a width of cut of $\frac{3}{4}$ of the diameter. This seemed to be an unfortunate combination of cutting conditions and is held against reaching the maximum depth of cut for this tool.

Tests wall of 60 mm height

TEST1-0398-1A

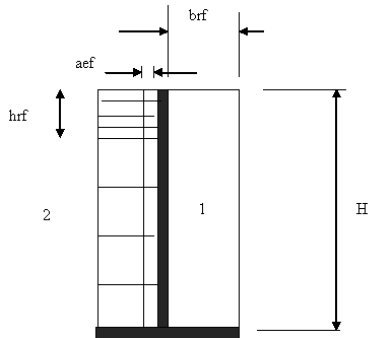

Figure A.4: Test 1-0398-1A

Tools:

7033021 Dia 20 Lu=80 S23000 F10000 (0.22/t), feature 1, 3.

7033009 Dia 12 Lu=75 S18000 F4224 (0.12/t), features 2, 4.

a_p 1.5 mm

Wall thickness is 1 mm. Wall length is 120 mm.
 $B_{RF} = 11$ mm, $h_{RF} = 12$ mm, $H_{RF} = 60$ mm, $a_{ef} = 2$ mm

Very light vibration on top.
Satisfactory surface results.

TEST2-0398-2A

As previous test, but the target wall thickness t was 0.8 mm instead of 1 mm.
Satisfactory surface results.

TEST3-0398-3A

Two tests, machined as the previous test, but the target wall length and thickness were different.

Test 28 * 0.85 * 60: Heavy vibration on top of the wall.

Test 70 * 0.85 * 60: Light vibration on top of the wall.

TEST4-0398-4A

As the first and second test of walls of this height, but the target wall thickness t was 0.6 mm.
Satisfactory surface results.

Minimal vibration at a distance of approximately 15 mm from the top.
The measured thickness is a constant 0.65 mm across the entire wall, which is a structural 0.05 mm deviation. This is within tolerance.

Tests wall of sizes 120 * 0.75 * 72

TEST11-0398-1A

Tools:
7033021 Dia 20 Lu=80 S23000 F10000 (0.22/t), feature 1, 3.
7033009 Dia 12 Lu=75 S18000 F4224 (0.12/t), features 2, 4.
 a_p : 1.5 mm

$B_{RF} = 11$ mm, $h_{RF} = 12$ mm, $H_{RF} = 36$ mm, $a_{ef} = 2$ mm

Result: vibration marks on top of the wall on the small machining features side.

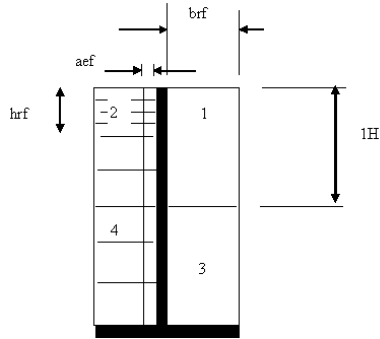

Figure A.5: Test 11-0398-1A

Tests wall of sizes 120 * 1 * 72

TEST8-0398-1A

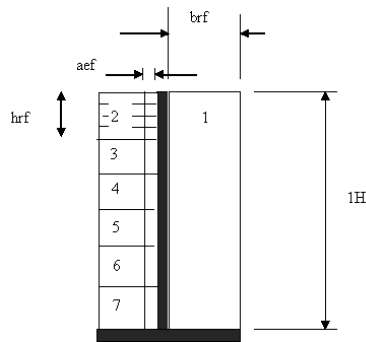

Figure A.6: Test 8-0398-1A

Tools:

7033021 Dia 20 Lu=80 S23000 F10000 (0.22/t), feature 1; a_p 3.0 mm

7033010 Dia 12 Lu=38 S28000 F8400 (0.15/t), features 2, 3, 4; a_p 3.0 mm

7033009 Dia 12 Lu=75 S18000 F4224 (0.12/t), other features; a_p 1.5 mm

$B_{RF} = 11$ mm, $h_{RF} = 12$ mm, $H_{RF} = 72$ mm, $a_{ef} = 2$ mm

Vibrations occurred for operations using tool 7033010 (for features 2, 3 and 4). The other tools gave satisfactory results.

TEST8-0398-1B

As the previous test, with speed and feed for operations using tool 7033010 reduced to 80%.

The vibrations for tool 7033010 (features 2, 3 and 4) were considerably less, but the result remained unsatisfactory. The operations using the other tools still gave good results.

TEST8-0398-2A

As the first test with these wall sizes, but with one 12 mm mill and one depth of cut:

Tools:

7033021 Dia 20 Lu=80 S23000 F10000 (0.22/t), feature 1

7033009 Dia 12 Lu=75 S18000 F4224 (0.12/t), other features

a_p 1.5 mm

The vibrations while machining features 2, 3 and 4 continued to occur. The tool and depth of cut do not seem to influence these vibrations.

TEST9-0398-3A

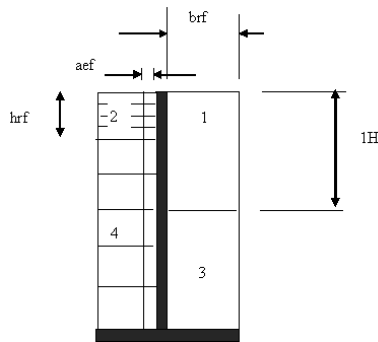

Figure A.7: Test 9-0398-3A

As the previous test, but with H_{RF} reduced to 36 mm instead of 72 mm. (H_{RF} equals three times h_{RF} instead of six times h_{RF}).

Tools:

7033021 Dia 20 Lu=80 S23000 F10000 (0.22/t), feature 1, 3.

7033009 Dia 12 Lu=75 S18000 F4224 (0.12/t), features 2, 4, etc.

a_p 1.5 mm

Satisfactory surface results.

TEST10-0398-4A

As the previous test, but with $H_{RF} = 48$ mm (and 24 mm) instead of 36 mm. This H_{RF}/h_{RF} ratio of four gave good results for tests on walls with a height of 48 mm.

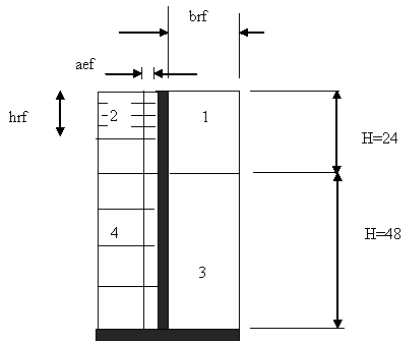

Figure A.8: Test 10-0398-4A

Vibrations occurred. Apparently, $H_{RF} = 4 \cdot h_{RF}$ is good for a 48 mm high wall, but this ratio is too great if the wall height exceeds $4 \cdot h_{RF}$ for this length and thickness.

TEST20-0398-1A

As test TEST9-0398-3A, with $B_{RF} = 11$ mm, $h_{RF} = 12$ mm, $H_{RF} = 36$ mm, $a_{ef} = 2$ mm, but using a large (20 mm) mill and depth of cut:

Tools:

7033021 Dia 20 Lu=80 S23000 F10000 (0.22/t), all features. a_p 3.0 mm

Considerable vibrations occurred in the upper part on the side of the small machining features.

Tests wall of sizes 144 * 1 * 72

TEST17-0398-1A

As test TEST8-0398-2A, but with wall length 144 mm instead of 120 mm.
($B_{RF} = 11$ mm, $h_{RF} = 12$ mm, $H_{RF} = 72$ mm)

The result is better than the TEST8-0398-2A result.
The length in this case has a positive effect.

Remarks

Some additional comments from Fokker Aerostructures:

- For some tests, cutting conditions - spindle speed, feed, depth and width of the finishing cut - have been varied in an attempt to optimise results. In other tests, only sizes of stiffness features and removal features have been changed. It has clearly been demonstrated that these feature sizes influence the results.

- Other tests have been performed before those described above, using a 20 mm diameter tool for finishing, for both peripheral and face milling of a wall (110 * 1 * 80 mm), without satisfactory results. For this reason, combined with the fact that currently most finishing passes are employed with a 12 mm diameter tool, further tests also used a 12 mm diameter tool.
- No other tests were performed using face milling. Peripheral milling is usually preferred for finishing passes for thin geometry, but it cannot always be applied due to accessibility, for example for machining features of large walls (webs) in a part.

A.2 Model parameters

The tests described in section A.1 performed for the size model from section 4.1.2, have provided insufficient data to choose all model parameters based upon practical results. The values of the model parameters that are currently used in the sizing model, given in table A.2, are based upon a mixture of results from the tests, theory and process planning experience.

The model also uses parameters representing material properties. These parameters' values, for aluminium in this project, are taken from material handbooks.

The maximum milling force is based upon simulation data gathered by Fokker Aerostructures. This data indicates that for their application, milling forces do not exceed this value when machining near the product surface [Ouwkerk 2003]. The roughing and finishing sizes of the cuts are based upon process planning experience. Preferred cutting tool properties are based on those commonly used for finishing thin walls at Fokker Aerostructures. The initial machining feature sizes come from process planning experience and fitting the model upon the performed milling tests. The effective length factor is based upon theory first and tuning the model second. The chosen value for the allowed deflection gives good mapping of the model on the feature tests and gives a substantial safety factor with respect to the tolerance. (Note that 'fitting' and 'good mapping' are not meant in the sense of predicting bending deviations correctly, but in the sense of calculating machining feature sizes that gave good - sufficiently accurate - results in the tests.) The generally used tolerance at Fokker Aerostructures is a surface profile tolerance of 0.127 mm. The theoretical allowed deviation without safety is half this tolerance, i.e. 0.0635 mm (see also the subsection on tolerance interpretation in section 4.1.2). The chosen allowed deviation of 0.01 mm thus gives a safety factor larger than 6 in this case.

In the implemented calculation model, most of the above described parameters can be provided as input to the calculations. The above values serve as defaults, used when no other value is passed in.

Parameter	Value
Allowed deflection	0.01 mm
Effective length factor (length/height)	4
Maximum milling force	200 N
Preferred tool diameter	12 mm
Initial machining feature heights ratio (H_{RF}/h_{RF})	2
<i>Peripheral milling specific</i>	
Size of vibration remachining danger zone on tool	$\frac{3}{4} * D_{preferred}$ mm
Assumed finishing width of cut	2 mm
Assumed roughing stepover	0.75
Assumed (finishing) depth of cut	1.5 mm
Initial number of (finishing) cuts in h_{RF}	8
Initial machining feature width (B_{RF})	At least 2 cuts, from stiffness-based rule of thumb
<i>Face milling specific</i>	
Size of vibration remachining danger zone on tool	$\frac{1}{2} * D_{preferred}$ mm
Assumed finishing depth of cut	2 mm
Assumed roughing depth of cut	4 mm
Assumed finishing width of cut	$\frac{1}{2} * D_{preferred} + 1$ mm
Initial number of (finishing) cuts in h_{RF}	3
Initial machining feature width (B_{RF})	At least 3 cuts, from stiffness-based rule of thumb

Table A.2: Parameter values currently used for the machining feature sizing model