



ELSEVIER

Int. J. Production Economics 46–47 (1996) 521–533

international journal of  
**production  
economics**

## Tool sharing in parallel part production

G.J.C. Gaalman<sup>a,\*</sup>, W.M. Nawijn<sup>b</sup>

<sup>a</sup> Faculty of Management and Organization, University of Groningen, Netherlands

<sup>b</sup> Department of Applied Mathematics, University of Twente, Netherlands

---

### Abstract

A group of identical NC machines, laid out in a line, manufactures relatively few part types in large batch size. Parts of the same type are processed by the machines simultaneously. The operations on a part are performed by one machine only, using a part type specific tool set. During batch production the tool magazines of the machines contain the same set of tools. If the machine group is provided with an automatic tool transport system then tools can be shared. Therefore, the number of identical tools can be reduced and savings with respect to investment in tools are possible. A disadvantage of tool sharing is that machines might become idle because tools have not arrived in time. Suitable dispatching and scheduling of the tool transportation device can reduce these machine waiting times.

In this paper the characteristics of the production situation are examined. The consequences of three tool transport policies with respect to transport time and transport frequency of the transportation device are analyzed. Analytical results are presented and some extensions are discussed. The method presented provides a way to analyze transport rules in this type of systems.

*Keywords:* Tool sharing; Parallel production; Production situation

---

### 1. Introduction

The widespread use of CNC machines in mechanical discrete part production has caused radical changes with respect to process planning (NC program preparation), tasks of operators, workpiece flow and auxiliary flows (cutting tools, fixtures). The use of versatile CNC machines has led to an increasing number of tools and fixtures. The number of unique tools necessary may be more than the number of parts being processed [1]. The initial investment in tools and fixtures is significantly increased. Viehweger [2] indicates that for a single

CNC machine center tools account for 29% and fixtures for 28% of the total invested capital. Other sources note that: in flexible manufacturing systems (FMSs) tools and fixtures may reach up to 25% of the total FMS investment [3]; tooling is, with 25–30%, the major component of variable costs [4]; annual budgets for tooling, jigs, fixtures, consumable supplies and spare parts are seven to twelve times larger than the entire capital equipment budget [5]. The flow of tools and fixtures in part manufacturing has been enlarged as a consequence of these developments, causing serious problems like: 40–80% of a foreman's time is spent looking for and expediting materials and tools, 16% of scheduled production cannot be met because tooling is not available, 30–60% of the

---

\* Corresponding author.

tooling inventory is somewhere on the shop [5, 6]. Hence, for efficient control of advanced manufacturing systems the management of auxiliary resources is essential. To avoid high production costs caused by idle times on expensive CNC machines, overinvestments in tools, unnecessary delivery delays, quality problems and activities of operators, the auxiliary flows should be planned, controlled and monitored. Whereas traditionally much attention was paid to the control of the workpiece flow, at present tools and fixtures must be planned and scheduled along with workpieces. Also, because of decreasing part delivery times the coordination between these flows should become tighter.

There is a growing recognition that the management of auxiliary resources, especially of cutting tools, is very important in automated manufacturing. This is also reflected in published work in the literature. A comprehensive survey of tool management issues is given by Veeramani et al. [7] and Gray et al. [8]. Tool management comprises a variety of functions, among others: tool provisioning, tool preparation, tool allocation, tool transport. These functions are planned and controlled on several levels of the planning hierarchy [8].

In the literature the FMS loading problem has been extensively discussed; [9–11] to name a few. This typical short range planning problem involves the assignment of operations and tools of selected part types to machine groups, taking into account technological and capacity constraints. The assignment of operations and tools does not change over the production period (for example day, week); at the start of a production period the tools are loaded in the tool magazines of the machines assigned. On the operational level the progress of parts through the system is often realized by means of release and sequencing rules [12, 13]. During the production period tools might be replaced due to wear or breakage, but there is no active tool scheduling support provided. The number of identical tool types to be provided (an FMS design or configuration issue) is also significantly influenced by the loading policy. Because during the production period identical tool types in different machines are not shared, a rather large number of duplicates seems necessary. This approach seems therefore applicable when there are relatively high tool

changing times and/or sufficient capacity of tool magazines and/or rather stable part mixes.

Automatic tool handling devices are offered by a number of FMS vendors. Automatic tool transport permits computer controlled tool movement between CNC machines and/or between a machine and the central tool store. This offers the possibility of a more efficient use of tools, which may reduce the number of tools required. So, in the design phase of an FMS the effects of tool sharing on tool investments should be evaluated. In addition, the traditional FMS loading and scheduling procedures must be reconsidered. The usefulness of an automatic tool handling device depends strongly on the characteristic of the FMS, the part-mix, the stability of the part demands, the operation times versus the tool lives, etc. In most cases a detailed simulation study is proposed to analyze an FMS [14–16, 2].

In the next section the context of our investigation is given. Here an FMS is described whose production properties lead us to analyze a model of the FMS. We will consider the performance of three transport rules to control the tool transport (Section 3). Then we discuss some extension. We will end with some concluding remarks.

## 2. Problem context

The analyzed FMS consists of  $2 \times 4$  identical CNC machining centers linked together by an in-line material handling system (see Fig. 1). Each CNC center has one input and one output buffer and a tool magazine. The FMS performs drilling and tapping operations on cylinder blocks and cylinder heads of three engine types. Four machines on one side work on heads, the opposite (located) machines work on blocks. Batches of 100–200 identical part types (blocks or heads) are produced by a group of four machines. All the operations on a part are processed on one single machine. The demand for parts is fairly stable.

Due to the complete processing of parts on machines, the production planning and scheduling of the FMS is rather simple. The production policy however has important consequences for the tool provision system. Each time a new part type is

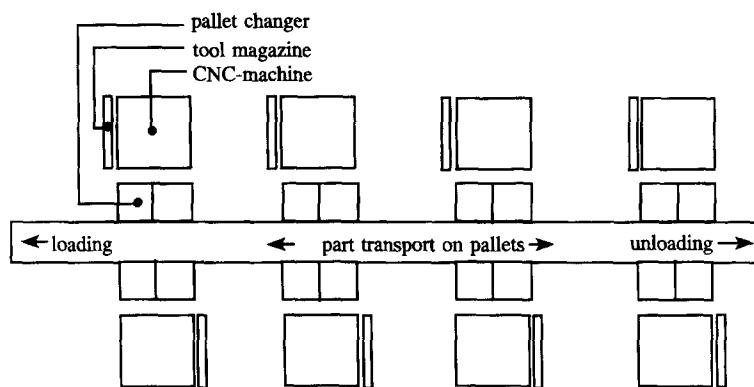

Fig. 1. Layout of the flexible manufacturing system (FMS).

selected, the tool magazines of the associated CNC machines must be loaded with tools to be used for that part type. The operations on a block need about 45 different tools, for a head about 29 tools are needed. The tool sets have a small overlap. Consequently, for each part type 4 tool sets and 2 to 3 reserve tool sets are necessary. The corresponding investment in tools is fairly high, about 30% of the investment in the FMS. One possible solution is to provide the FMS with a tool handling device.

In [17], the outcomes of a feasibility study were reported in the design phase of the FMS. Through a detailed simulation study the potential advantages of a simple automatic tool handling system for each group of four CNC machines were investigated. The system offers the possibility of fast transport of one single tool between machines and between a machine and the reserve tool magazine (see Figs. 2 and 3).

The simulation model takes into account: (1) necessary exchanges of worn tools by new ones from the ancillary tool magazine; (2) machine breakdowns due to tool breakage. A broken tool is manually removed and replaced by a new one, while the associated operation is finished outside the FMS. The flow of tools is controlled by a simple tool transport policy: tools are transported as soon as possible. Upon completion of an operation, a tool is immediately assigned to the machine that needs this tool type first (machines which have already this tool type are excluded). The tool trans-

port starts as soon as possible, and transports are executed in order of increasing future tool requirements (tooling events).

Several simulation runs indicated that a considerable reduction in tool investments (about 50%) is possible, while the machine idle times caused by waiting for tools are less than 2% of the total operation time with a utilization of the tool transportation device of about 50%.

The reduction in tool investments outweighs the investment in the automatic tool handling device. The estimated investment is about 25% of the original (estimated) investment in tools.

One of the research issues formulated in this study was to analyze other tool transport policies. Under the chosen policy, tools are transported as soon as possible based on estimations of future tooling events. However, due to breakdowns and congestions in the transport system, waiting times for tools can occur, causing a difference between the (actual) events and the estimated ones. In that case the distribution of tools over machines may not be in correspondence with the actual tooling events, and additional tool transports to update the system are necessary. This obvious drawback might be remedied by a policy based on: a machine calls for a tool as late as possible. Simons [18] tested this rule in his simulations. In view of the finite transport times, machines call for tools some moment before the (estimated) tooling events. The difference between this ordering moment and the tooling event can be viewed as a planned tool delivery time.

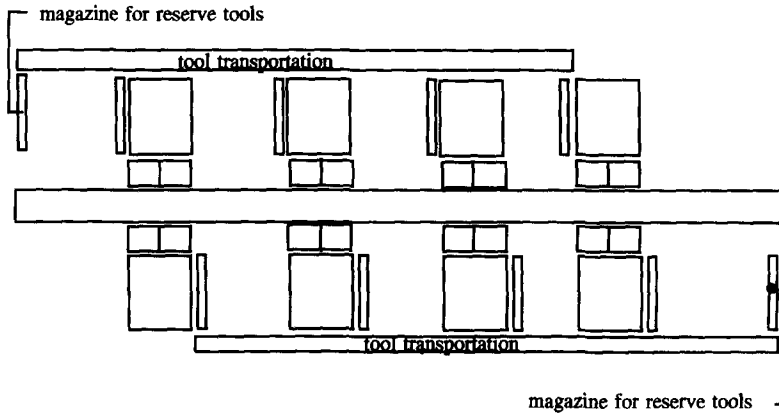

Fig. 2. Layout of the FMS using tool sharing.

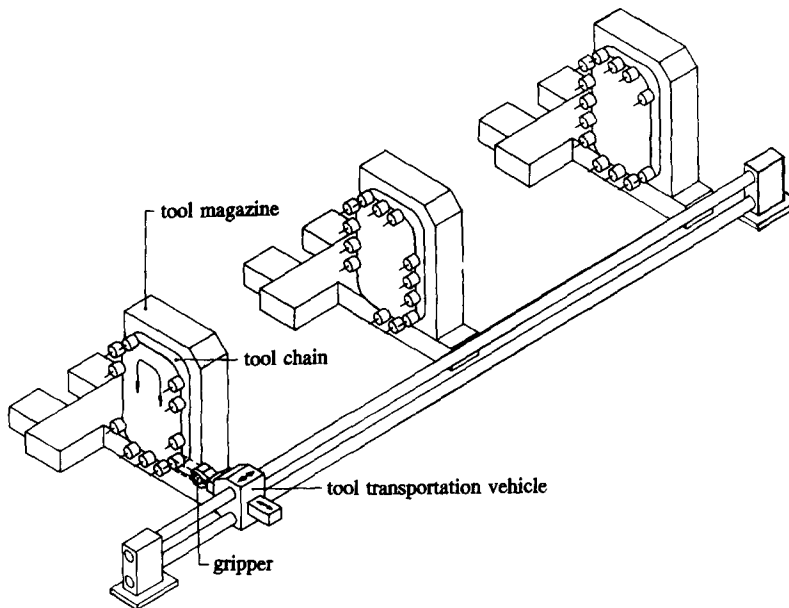

Fig. 3. A possible tool transport system.

A large tool delivery time leads to a rule equivalent to the “as soon as possible” rule. A small tool delivery time causes machine idle times, because tools are arriving too late. Simons experimentally found an optimal tool delivery time. The “as late as possible” rule does not uniquely identify a tool to be transported among the available tools of a certain type. An additional requirement is either to select a tool from a machine that needs this tool type the latest or to select the tool with the smallest

transport time. Simons found no distinct difference between these two possibilities. Using the first option, Simons showed that for the reduced tool set found by Gaalman et al., the machine idle times and the utilization of the transportation device can be reduced further, or, for the same idle times and utilization, the investment in tools could be reduced by an additional 10%.

Both the simulation studies demonstrated the feasibility of tool sharing. The importance of tool

transport policies is shown. However, only two policies are tested and the number of identical tools is found heuristically. Many solutions seem to be possible. The way in which a tool policy and the number of identical tools influence the system performance is difficult to establish from these studies. For example, the process plan, i.e. the number of operations, the various operation times, the number of tool types and the number of times a tool type is used, plays a crucial role, but how it does is not clear. Also the analysis is obscured by the random machine breakdowns and the exchange of worn tools.

The objective of this paper and a forthcoming one is to provide insight in the system performance by developing analytical expressions using simplified models. In this paper we will analyze the effect of the number of identical tools and the tool transport policy on transport times in the system. In the forthcoming paper we concentrate on production rates and machine idle times given a tool transport policy.

In the sequel the following simplifying assumptions are made: (a) only one (general) part type is considered with an infinite batch size; (b) the part type requires  $N$  different sequential tooling operations with processing times  $a_i$  ( $1 \leq i \leq N$ ); (c) there are  $m$  (identical) parallel machines; (d) the machines share  $n_i$  identical tools to perform operation  $i$ ; (e) the transport time of the tool device between two machines  $j$  and  $k$  equals  $|j - k|d$ ; (f) machine breakdowns and exchange of worn tools are disregarded.

In Section 3 we analyze the effects of tool transport rules on transport times and frequency for a given ordering of starting (and finishing) times of the tooling operations. In Section 4 some extensions are discussed. Finally, some concluding remarks are made.

### 3. Tool transport policies

We assume that initially the first  $n_i$  machines of the  $m$  machines ( $n_i \leq m$ ) in the system are provided with one tool of type  $i$  ( $1 \leq i \leq N$ ), where the machines are numbered in order of their position in the line. This is in correspondence with the way in which the parts are initially delivered to the ma-

chines. When running the system, the tools should be expedited among the machines. A tool transport rule is used to decide which tool out of the candidate tools will visit a calling machine. It should be noted that the transport policy is thus induced by a local decision rule. Besides the tool transport policy, the number of identical tools influences the starting (and finishing) times of the operations on the parts. Given the  $n_i$  tools, at most  $n_i$  ( $> 1$ ) operations  $i$  on different machines can overlap. Thus, at an arbitrary moment no more than  $n_i$  operations are running.

Using a tool policy with a given number of identical tools, a cyclic progression of the system arises. The starting times of identical operations on consecutive machines will generally be out of phase. That is to say, let  $x_{k,i}(r)$  denote the starting time of operation  $i$  of the  $r$ th part on machine  $k$ , then

$$x_{j,i}(r+s) \geq x_{j-1,i}(r+s) \geq \dots \geq x_{1,i}(r+1) \\ \geq \dots \geq x_{k+1,i}(r) \geq x_{k,i}(r),$$

$j > k$  and  $s > 1$ .

**Example 1.** Consider a system with  $m = 4$ ,  $N = 3$ ,  $a_1 = 1$ ,  $a_2 = 2$ ,  $a_3 = 4$ ,  $n_1 = 1$ ,  $n_2 = 2$ ,  $n_3 = 3$  in which the transport times are ignored. Fig. 4. shows the Gantt chart for the first 12 parts of the (infinite) batch to be produced, starting from  $t = 0$ . The tool policy sends a vacant tool to the machine that needs it at first.

Operation 1 on machine 1 (M1) starts at  $t = 0$ . After finishing this operation the tool can be sent to one of the machines M2, M3 and M4, they all are waiting from  $t = 0$ . The transport policy however cannot unambiguously select a machine. It is in this case reasonable to choose machine 2, because it has the shortest tool transport time and it is initially provided with more tool types than the other ones. After that, respectively, M3 and M4 receive the tool. This results in starting times of 0, 1, 2 and 3.

Since the tools are already available on M1 and M2, the second operations of the first parts can start immediately after the first operations respectively at  $t = 1$  and 2. At  $t = 3$  operation 2 on M1 is finished. Machines 3 and 4 are calling. The tool is transported to M3 because this machine can start earlier. Machine 4 gets the tool from M2. Note that no more than two operations overlap.

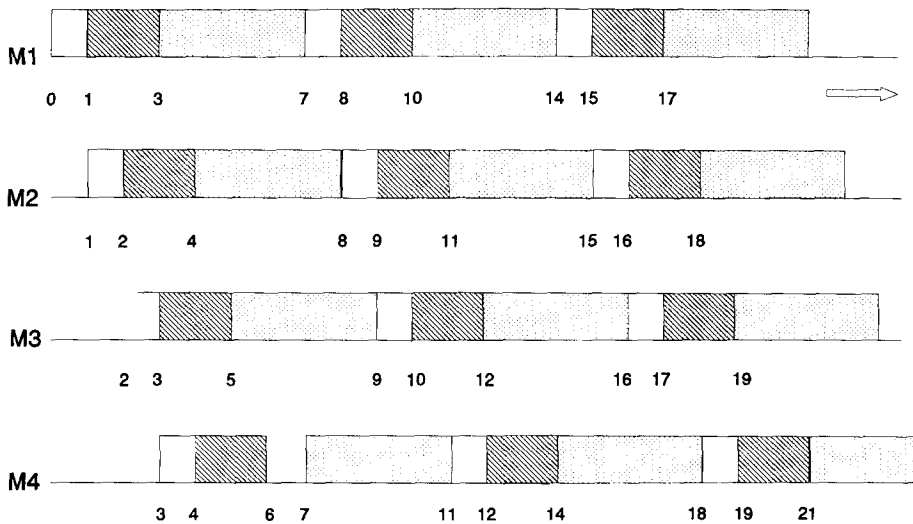

Fig. 4. The evolution of the system.

The operations 3 on M1, M2 and M3 can start directly after operations 2. Since there is no tool available, machine 4 cannot start at  $t = 6$ . At  $t = 7$  the tool on M1 becomes vacant and this is sent to M4. So machine 4 is idle from  $t = 6$  to  $7$ . Observe that three operations 3 overlap.

The first operation of the second part on M1 can start at  $t = 7$  receiving the tool from M4. The operations 1 on the other machines start at  $t = 8$ , 9 and 11. The operation 2 of the part 2 on M1 can receive a tool from either M3 or M4. The transport policy assigns the tool at M3 to M1. Similarly operation 2 of part 2 on M2 gets the tool from M4. Operation 2 on M3 start at  $t = 10$  with the tool from M1. Operation 2 on M4 starts at  $t = 12$  using the tool from machine M2, although the tool at M3 is also available.

Operations 3 on M1 and M2 receive the tool from, respectively, M2 and M3 and start at  $t = 10$  and 11. Principally, M1 could also get the tool from M3, and M2 that at M4. The tool to execute operation 3 on M4 comes from M1.

All the operations of part 2 on machines can start without any delay. The same holds for the next parts of the batch. After a transient period, a cyclic progression arises, where the starting times are out of phase. Apart from the delay between  $t = 6$  and  $7$ , there is no idle time in this case. In the forthcoming

paper we will derive conditions for this.

The transportation device transports several tools between the machines. We restrict the analysis to tool movements of one tool type  $i$ . The interfering transports for other tool types are not taken into account. Moreover, only direct transports of the tools of type  $i$  between subsequent machines are considered. So, the transport times of movements necessary for the device to start a new transport for tool type  $i$  are not accounted for. In the next section we discuss two possibilities to estimate this time. Finally, it is assumed that any of the  $n_i$  tools can be selected to serve a calling machine.

The starting times of the operations depend on the number of machines  $m$ , the number of tools  $n_i$  ( $i = 1, \dots, N$ ), the operation times and the tool transport policy. We compare different tool policies for the same pattern of starting times. Of course, the exact pattern will be influenced by the policy used. The analysis will be carried out under the assumption that the relative ordering of the starting times remains the same for all three policies to be considered. Fig. 5 shows the ordering of the starting times we will analyze ( $tk$  is similar to  $x_{k,i}(r)$  for  $r = 1, 2, \dots$  and the operation  $i$ ). Only 12 of the infinite number of starting times are presented. Referring to Example 1, the starting times of the third operations of the parts correspond with  $t1 = 3$ ,

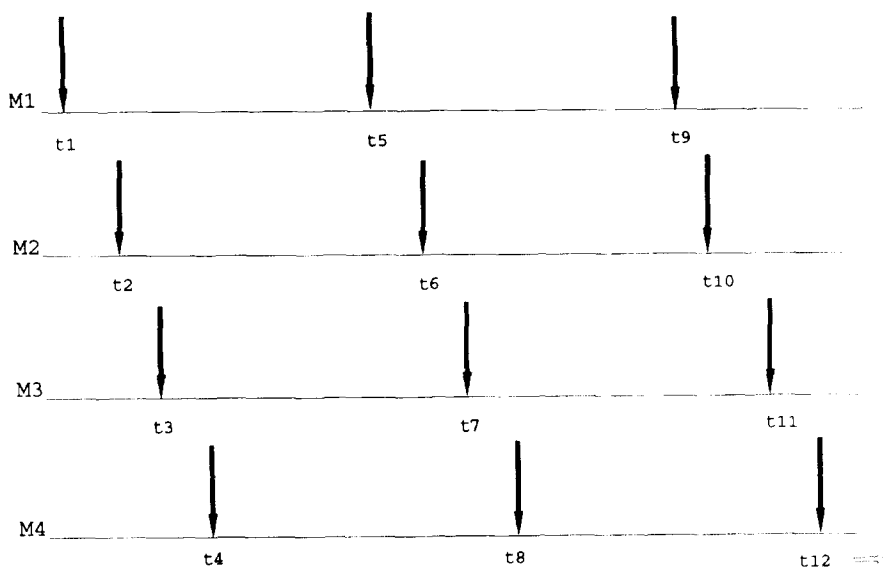

Fig. 5. Out of phase pattern for four machines.

$t_2 = 4$ ,  $t_3 = 5$ ,  $t_4 = 7$ ,  $t_5 = 10$ ,  $t_6 = 11$ ,  $t_7 = 12$ ,  $t_8 = 14$ ,  $t_9 = 17$ , etc.

The above assumptions will give us the possibility to derive analytical expressions for the (direct) transportation times. Due to the presumed out-of-phase pattern and the stationarity of a transport policy, the transport tasks will show a repeated or cyclic character. That is to say, given an initial location of the  $n_i$  tools on machines, exactly the same location of tools is reached after  $p = qm$  (with  $q$  integer) transports,  $q$  will be called the period. Different policies can have different periods. In order to compare the transport policies, the performance is measured per part cycle (corresponding with operations on  $m$  consecutive machines, see Fig. 5, illustrating three part cycles) or per machine. Three performance measures will be presented:

(1) The average total transport time per part cycle:  $t_{ip}$ , defined as the total transport time in  $q$  cycles for tool type  $i$ , divided by  $q$ . Dividing  $t_{ip}$  by  $n_i$ , yields  $t_{ip}/n_i$ , the (average) total transport time per tool per part cycle. This quantity plays an important role in analyzing the idle times of the system. Dividing  $t_{ip}$  by  $m$  results in  $t_{am}$ , the average transport time per part cycle.

(2) The transport frequency:  $f$ . This frequency denotes the fraction of operations for which the

corresponding tool is transported to another machine. If  $f = 1$  then a tool is always transported after completing an operation on a machine. Note that  $mf$  gives the average number of transports per cycle, so dividing  $t_{ip}$  by  $mf$  yields the average transport time of executed transports, denoted by  $t_{at}$ . In this case zero transports (a tool remains on a machine) are not accounted for.

(3) The maximum transport time:  $t_{max}$ , defined as the maximum possible transport time of a tool between two machines in a part cycle.

The first tool transport policy we consider is the "as soon as possible" rule (E-rule) used in [17]. As soon as a tool has finished its operation on a machine, the tool is assigned to the machine, that needs this tool type first and transport is executed.

**Proposition 1.** For the E-rule the average total transport time per part cycle, the maximum transport time and the transport frequency for tool type  $i$  are given by

$$t_{ip} = 2d(m - n_i)n_i, \quad (1)$$

$$t_{max} = d[\max(m - n_i, n_i)] \text{ and } f = 1.$$

We illustrate this policy by an example.

**Example 2.** Consider a system with  $m = 4$ ,  $n_i = 2$ . The tool movements of tool type  $i$  given the E-rule are depicted in Fig. 6. The first tool serves respectively machines 1, 3, 1, 3, ... and the second tool serves machines 2, 4, 2, 4, ... (the arcs in Fig. 6 are drawn to enlighten the movements). Consider, for instance, the tool performing the second operation on machine 1. Upon completion of the operation it is sent to the first machine that needs a tool of this type, which is machine 3. We observe that the two tools always leave the machines after finishing an operation, so  $f = 1$ . The maximum transport time  $t_{\max} = 2d$ . The total transport time per part cycle  $t_{\text{tp}} = 8d$ . The transport time per tool per part cycle  $t_{\text{tpp}} = 4d$  and  $t_{\text{am}} = t_{\text{at}} = 2d$ . Observe that the initial starting position of the tools is reached again after one part cycle or four transports. In general, the period for this policy will be  $q = n_i / \text{g.c.d.}(m, n_i)$ , where  $\text{g.c.d.}(m, n_i)$  is the greatest common divisor of  $m$  and  $n_i$ .

The second tool transport policy (L-rule) to be considered assigns to a calling machine an available tool from the machine that needs this tool type the latest (again) in the future.

**Proposition 2.** For the L-rule the average total transport time per part cycle, the maximum transport time and the transport frequency for tool type  $i$  are given by

$$t_{\text{tp}} = 2d(m - n_i), \tag{2}$$

$$t_{\max} = d(m - 1) \quad \text{and} \quad f = \frac{(m - n_i)}{(m - 1)}.$$

In this case a tool is not always transported to another machine after completing its operation (although no tool remains on a machine continuously) and thus  $f < 1$  (for  $1 < n_i \leq m - 1$ ). The average total transport time per part cycle is strictly smaller than under the E-rule if  $n_i > 1$ . In the Appendix it will be shown that this policy minimizes the total transport time. Fig. 7 shows the movements of the tools using the L-rule for the system of example 2. Tool no. 1 visits the machines 1, 1, 2, 3, 3, 4, 1, ... and the second tool 2, 3, 4, 4, 1, 2, 2, ... (see also the drawn arcs). Consider for instance the first operation on machine 3. It will retrieve the tool from machine 2 instead of machine 1, since machine 2 needs a tool later than machine 1. We note that

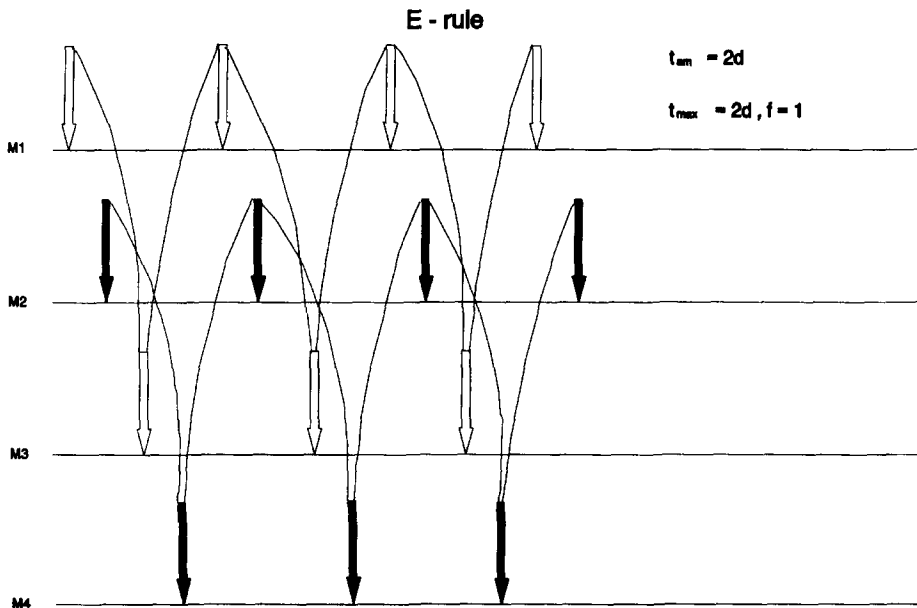

Fig. 6. Tool movements using the E-rule.



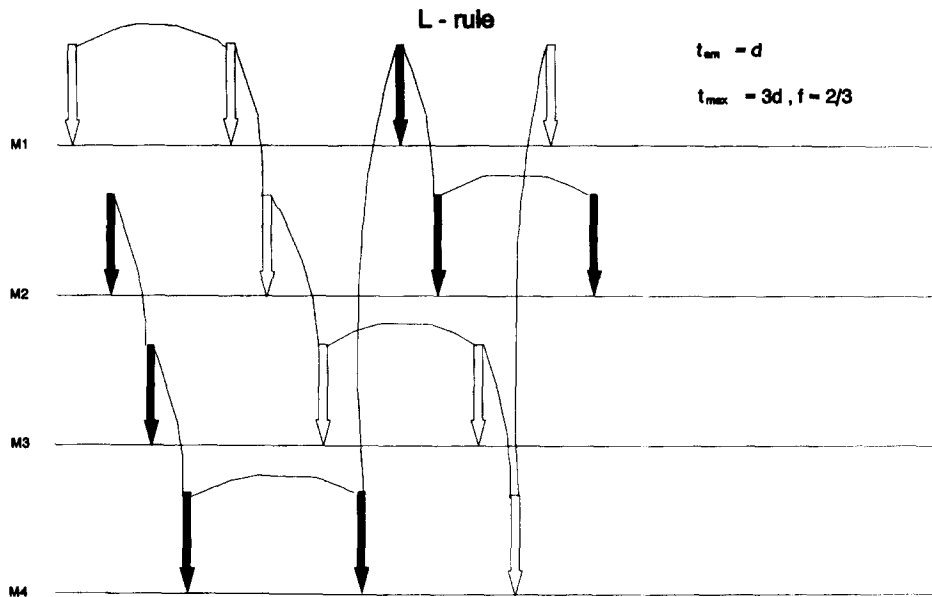

Fig. 7. Tool transports for the L-rule.

the initial position of the tools is reached again after 3 part cycles. The period can be obtained from  $q = (m - 1)n_i/\text{g.c.d.}(m, n_i)$  and is larger than the period of the E-rule. The transport frequency  $f = 2/3$ , so in 33.3% of the cases a tool stays on the machine for the next operation. The total transport time per part cycle  $t_{ip} = 4d$ . Because a tool does not always leave a machine,  $t_{am}$  and  $t_{at}$  are different;  $t_{am} = d$  and  $t_{at} = 3d/2$ . The maximum transport time in this case is  $3d$ .

The last policy we consider is the shortest transport time rule (S-rule). A calling machine receives an available tool from a machine for which the transport time is minimal. In some cases one can choose between two machines, then the L-rule is used to break the tie.

**Proposition 3.** For the S-rule the average total transport time per part cycle, the maximum transport time and the transport frequency for tool type  $i$  are given by

$$t_{ip} = 2d(m - n_i), \tag{3}$$

$$t_{max} = d(m - n_i) \quad \text{and} \quad f = \frac{m + 1 - n_i}{m}.$$

For this policy, after an initial period, only one tool visits the lowest numbered machines. The other tools remain at the highest numbered machines. For  $n_i > 1$  the transport frequency is greater than that of the L-rule. The period for this policy  $q = 1$ . The average total transport time per cycle is equal to that of the L-rule and thus also minimal. Despite the higher transport frequency, this is possible because the maximum transport time is lower. In Fig. 8 the results of the S-rule are shown for Example 2 (see the arcs). Consider the second operation on machine 4. Choosing between the tools on machines 3 and 4, the rule prescribes the tool that already resides on machine 4. After two transports tool no. 2 stays on machine 4 and tool no. 1 services the other machines. The transport frequency is  $f = 3/4$ . The total transport time per part cycle  $t_{ip} = 4d$ , results in  $t_{am} = d$  and  $t_{at} = 4d/3$ . The maximum transport time is  $2d$ .

We have examined in this section three transport policies for tool type  $i$ . Only direct transports between machines are taken into account. From  $t_{ip}$ , for each type  $i$ , we can obtain an estimate of the total direct transport time (per part cycle) of the transport device by summing over all tool types.

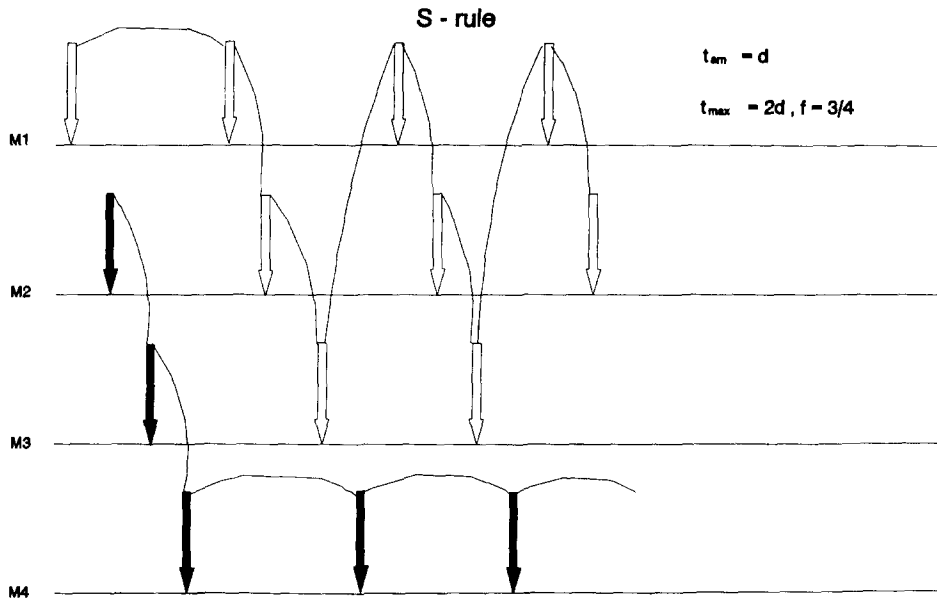

Fig. 8. Tool movements using the S-rule.

For example, the L-rule gives

$$t_{tot} = \sum_{i=1}^N 2d(m - n_i)n_i.$$

This time should be compared with the average cycle time to get an impression of the utilization of the transportation device.

Finally, it should be mentioned that the results obtained for the three rules are only dependent on the relative ordering of the starting times, which is of course induced by the initial loading of the machines. Results for other orderings can be obtained along these lines.

A number of other transport policies can be formulated. One such policy is to assign (in advance)  $n_i - 1$  tools to the first  $n_i - 1$  machines and one tool to the remaining machines. This policy is equivalent however to the S-rule. Another class of policies could be obtained by forming equal sized sets of machines and allocating to each set an equal number of tools, if possible. Within each set of machines several tool policies can then be used. Let  $k$  be the greatest common divisor of  $m$  and  $n_i$ , then to  $k$  sets of  $m/k$  machines  $n_i/k$  tools can be allocated. If we use the E-rule in each set then the total

transport time per part cycle will be  $2d(m - n_i)(n_i/k)$ . Since  $1 \leq n_i/k \leq n_i$  the transport performance of this policy lies between the S-rule and the L-rule (see Eqs. (1) and (2)).

Besides the analysis of other tool transport policies, the effects of some extensions of the model can be studied. In the next section we examine the consequences of the introduction of tool exchange times at the machines, which were neglected in this section. Moreover, we propose some approximations to account for the transport time to a machine, on which a tool is waiting for transport.

#### 4. Some extensions

When the transportation device arrives at a machine to retrieve a selected tool, then this tool should be loaded onto the device. The tool changing time can be split into two parts: (1) the time needed to bring the tool pocket of the tool magazine with the desired tool to the unloading place; (2) the time needed by the tool exchange mechanism to load the transport device. The first part depends on the actual position of the tool with respect to the

unloading place. This task might be executed in parallel with the transport of the transport device to the machine. So, in general it is difficult to find an exact value for the tool changing time. Here, we assume that the tool changing time is constant. For the time needed to unload the transport device and to load the tool magazine of the calling machine, we will take the same constant value, denoted by  $e$ . The transport time between two machines  $j$  and  $k$  now becomes  $|j - k|d + e$ .

The total transport time per part cycle of the three transport rules can now easily be adjusted. During a part cycle the average number of transports will be given by  $mf$ . So the total transport time  $t_{tp}$  should be augmented by the term  $emf$ , representing the total time spent on tool changing. This gives, respectively, for the E-, L- and S-rules:

$$t_{tp} = 2d(m - n_i)n_i + em, \quad (1')$$

$$t_{tp} = 2d(m - n_i) + em(m - n_i)/(m - 1), \quad (2')$$

$$t_{tp} = 2d(m - n_i) + e(m + 1 - n_i). \quad (3')$$

By summing these equations over all  $i$  we obtain  $t_{tot}$ , the (average) total transport time per cycle for all tools. Observe that the L-rule now outperforms the S-rule. As shown in the Appendix the L-rule remains optimal.

The transportation device is assumed to be always at the right location to execute its tasks. This means that if a tool should be transported from machine  $j$  to machine  $k$ , the time needed for the device to arrive at machine  $j$  to start this transport is not taken into account. The latter time will be referred to as transition time. Since the device performs transports for all tool types, its position prior to the transport  $j \rightarrow k$  is unknown. We discuss two possibilities to gain insight into the value of the transition time.

Possibility 1: The device is located with equal probability ( $1/m$ ) at one of the machines.

Possibility 2: The device is always positioned at a specific location. This could be a fixed location to which the device will return when there are no tasks to be executed. However, in designing the system we assumed that the device stays at the last visited machine. To obtain an upper bound on the transition time we assume that the device is located at the machine with the longest distance to the

calling machine. So we perform here a worst case analysis.

First, we analyze Possibility 1. The E- and L-rule prescribe the tool to be selected regardless of the location of the transportation device. So we see exactly the same tool transports as before. The term that should be added to the average total transport time per part cycle is for the E-rule:

$$t_{trans} = d \sum_{j=1}^m (1/m) \sum_{k=1}^m |j - k| \quad (4)$$

and for the L-rule

$$t_{trans} = df \sum_{j=1}^m (1/m) \sum_{k=1}^m |j - k| \quad (5)$$

with  $f = (m - n_i)/(m - 1)$

As formulated before, the S-rule selects a tool such that the direct transport time between the offering machine and the calling machine is minimal. The additional component to the average total transport time in this case is

$$t_{trans} = d \sum_{j=1}^s (1/m) \sum_{k=1}^m |j - k| \quad (6)$$

with  $s = m - n_i + 1$ .

Instead of minimizing direct transports we can also minimize the total transport time (transition and direct transport time) to execute a certain task. In this case the position of the transportation device is taken into account. This situation can be described by a Markov model, which is analytical solvable for small  $m$  and  $n_i$ . Since this S-rule takes care of the location of the device, the performance with respect to the other rules is (slightly) improved.

Possibility 2: In this case the average total transport time per part cycle  $t_{tp}$  should be adjusted with the maximum transition times to machines from where direct transport activities occur. This gives for the E-rule the extra term:

$$t_{trans} = d \sum_{j=r}^s \max(j - 1, m - j) \quad (7)$$

with  $r = 1$  and  $s = m$ , and for the L-rule:

$$t_{trans} = df \sum_{j=1}^m \max(j - 1, m - j). \quad (8)$$

For the S-rule there are again two implementations possible. In the first, the S-rule selects tasks such that the direct transport time is minimal. So the same tasks arise as originally. One tool serves the lower numbered machines. The total transport time is augmented by the term given in Eq. (7) in which  $r = 1$  and  $s = m + 1 - n_i$ . In the other implementation, the tasks are selected such that the total transport time is minimal. Now the position of the device influences the tasks to be selected. Due to the transition times, it is attractive to locate the  $n_i - 1$  tools equally distributed over the lower and higher numbered machines and one tool serves the machines in the middle. The correction term for the total transport time is then given by Eq. (7) with  $r = \lfloor (n_i - 1)/2 \rfloor + 1$  and  $s = m - \lceil (n_i - 1)/2 \rceil$ .

With these estimates of the transition times the total transport time per part cycle over all tool types can be derived. Comparing this time, with the (average) part cycle time, estimates of the utilization of the transportation can be found. Unfortunately, only explicit lower bounds for the average cycle time of the three policies exist. In principal, however, it is possible to determine the cycle times by numerical methods.

## 5. Summary and conclusion

The heuristic tool selection procedures described in Section 2 lead us to analyze several tool transport policies. In Section 3, emphasis was put on local decision rules. The performance of three rules was considered, under the assumption that machine cycles are fixed and out of phase. It was shown that two rules, i.e. the L- and S-rules, minimize the (direct) transport time of the transporter. Under the L-rule a tool needed on a certain machine is retrieved from the machine that needs this tool the latest among all machines. The performance of this rule with respect to the workload of the transporter is certainly better than under the E-rule, according to which a tool is immediately sent to the machine that needs this tool first. In Section 4, the influence of the tool exchange time in the tool transport time is considered. The L-rule remains optimal while the S-rule deteriorates. The incorporation of the transition time of the trans-

port device leads to a relative improvement of the S-rule. The analysis indicates that, in general, in a system in which transport times play an important role the L-rule is worth considering, and confirms the earlier simulation results of the FMS.

The method developed in this paper can be used to analyze the effects of other transport rules. The approach can be seen as a first step in the selection of suitable rules and number of identical tools, which can be evaluated further in a simulation model.

## Appendix

We briefly discuss one of the possibilities to show the optimality of the L-rule.

The problem to select a transport task from a machine to another machine can be modelled as a classical transportation problem. A transportation table can be defined where the supply points correspond with the successive tool availability moments and the demand points with the successive tool calling moments. The costs  $c_{jk}$  when a tool is transported from a machine  $j$  at an offering moment  $t_{j \bmod(m)}$  to machine  $k$  at a calling moment  $t_{k \bmod(m)}$  is equal to  $d|j - k| + e$ . Not all transports are allowed. From an availability moment there are  $m - 1$  tool transports possible to calling moments  $t_{j+1}, \dots, t_{j+m-1}$ . Moreover, a tool may stay on the machine, which corresponds with a zero transport to a calling moment  $t_{j+m}$ . Given the initial allocation of  $n_i$  tools on the first machines the first  $n_i$  calling moments are not included in the table. The assignment of transport tasks means that entries in the transportation table get value one. Applying the L-rule results in allocations in the transportation table, corresponding to a basic solution. Since the L-rule is cyclic, only  $p = mq = m(m - 1)(n_i/\text{g.c.d.}(m, n_i))$  offering moments from  $t_1$  to  $t_p$  are considered. This gives  $p$  calling moments from  $t_{1+n_i}$  to  $t_{p+n_i}$  and a  $p \times p$  table. There are now  $p$  assignments in the table showing that the problem is degenerate. In fact, the problem is a standard assignment problem. In order to solve the degeneracy,  $p - 1$  assignments at zero level are added. Now we are able to inspect the basic solution for a possible improvement by calculating the dual variables

$u_j$  and  $v_k$  and checking for each unused entry if  $c_{jk} - u_j - v_k < 0$ . Since such improvements do not exist the solution is optimal.

## References

- [1] Hutchinson, G., 1982. The impact of tooling on automated batch production. Proc. Technical Conf. National Machine Tool Builders Association, Chicago, pp. 447–452.
- [2] Viehweger, B., 1988. Für Bearbeitungszentren und Flexibele Fertigungssysteme: Tool-management in Zukunft immer Bedeutender. *Industrie-Anzeiger*, 110(29): 24–26.
- [3] Tomek, P., 1986. Tooling strategies related to FMS management. *FMS Mag.*, 4: 102–107.
- [4] Kuchinic, A.E. and Seidmann, A., 1988. Tool management in automated manufacturing: Operational issues and mathematical models. *Int. Ind. Eng. Conf. Proc.*, pp. 379–382.
- [5] Mason, F., 1986. Computerized cutting tool management. *Am. Machinists Automated Manufacturing*, 130(5): 105–132.
- [6] Hammer, H., 1988. Neuartiges Werkzeugschnellwechselverfahren für Bearbeitungszentren. *ZWF*, 83(4): 191–196.
- [7] Veeramani, D., Upton, D.M. and Barash, M.M., 1992. Cutting-tool management in computer-integrated manufacturing. *Int. J. Flexible Manufacturing Systems*, 3/4: 237–265.
- [8] Gray, A.E., Seidmann, A. and Stecke, K.E., 1993. A synthesis of decision models for tool management in automated manufacturing. *Mgmt. Sci.*, 39(5): 549–567.
- [9] Stecke, K.E., 1983. Formulation and solution of nonlinear integer production planning problems for flexible manufacturing systems. *Mgmt. Sci.*, 29(3): 273–288.
- [10] Kusiak, A., 1986. Applications of operational research models and techniques in flexible manufacturing systems. *Eur. J. Oper. Res.*, 24: 336–345.
- [11] Berrada, M. and Stecke, K.E., 1986. A branch and bound approach for machine load balancing in flexible manufacturing systems. *Mgmt. Sci.*, 32(10): 1316–1335.
- [12] Stecke, K.E. and Solberg, J.J., 1981. Loading and control policies for a flexible manufacturing system. *Int. J. Prod. Res.*, 19(5): 481–490.
- [13] Carrie, A.S. and Petsopoulos, A.C., 1985. Operation sequencing in an FMS. *Robotica*, 3: 259.
- [14] Perera, D.T.S. and Carrie, A.S., 1987. Simulation of tool flow within a flexible manufacturing system. Proc. 6th Int. Conf. on FMS: pp. 211–222.
- [15] Graver, T.W. and Mc Ginnis, L.F., 1989. A tool provisioning problem in an FMS. *Int. J. Flexible Manufacturing Systems*, 1: 239–254.
- [16] La Commare, U., La Diega, S.N. and Perrone, G., 1993. FMS management considering tool and part flow coordination. *Manufacturing Systems*, 22(4): 339–343.
- [17] Gaalman, G.J., Nawijn, W.M. and Platzer, L.W., 1987. Tool sharing in an FMS – A feasibility study. *Engineering Costs and Production Economics*, 12: 107–115.
- [18] Simons, W., 1987. Transportation rules to share tools. Master's Thesis, University of Twente (in Dutch).