

The Role of Sulfur Trapped in Micropores in the Catalytic Partial Oxidation of Hydrogen Sulfide with Oxygen

M. STEIJNS AND P. MARS

Department of Chemical Engineering, Twente University of Technology, Enschede, The Netherlands

Received December 7, 1973

The catalytic oxidation of hydrogen sulfide into sulfur with molecular oxygen has been studied in the temperature range 130–200°C. Active carbon, molecular sieve 13X and liquid sulfur were used as catalysts. Sulfur is adsorbed in the micropores ($3 < r < 40 \text{ \AA}$) of the catalysts. Experiments with a surface of liquid sulfur demonstrated that sulfur is a catalyst for H_2S oxidation.

This catalytic function reflects itself in the fact that H_2S oxidation rate showed a maximum as a function of the amount of sulfur present in the pores of active carbon and molecular sieve 13X. The kinetics of the reaction and the activation energy are equal on catalysts of different chemical composition.

The mechanism of the catalysis by sulfur is discussed as well as the function of traces of iron oxide, present in most catalysts.

INTRODUCTION

Hydrogen sulfide is nowadays mostly converted to sulfur by oxidation with sulfur dioxide in the Claus process. The SO_2 is formed in a separate step by combustion of a part of the H_2S in a flame. This process is not suitable for desulfurization of gases low in H_2S ($< 10 \text{ vol\%}$). With the old "dry box" system, in which a supported iron oxide-hydroxide medium is used, it is possible to treat gases low in H_2S (1). The reaction between H_2S and O_2 is not only catalyzed by this compound, but also by bauxite (2), alumina (3), active carbon (4) and molecular sieves (5). All these materials are porous; their chemical composition, however, is different. Depending on reaction conditions (temperature and relative pressures), these porous materials are used in practice as a catalyst or also as an adsorbent (6).

Little is known with certainty about the mechanism of the reaction on these catalysts. At temperatures below 100°C both water and sulfur will in most cases condense in the catalyst pores. The oxidation of H_2S may proceed in the liquid phase (water). An indication of this is the fact

that below 50°C a complete exhaustion of the H_2S by active carbon is only possible if the introduced gas has a relative humidity of at least 60% (7). Above 100°C the physical adsorption of water is in most cases of no significance, because of the very low relative pressure of water. In the literature many different factors have been mentioned as playing a role in the oxidation mechanism in this temperature region:

According to Swinarski, Siedlewski and Rozwadowski (8) the surface oxides of active carbon are the active centers where the oxidation takes place.

An important role is attributed to free radicals on the carbon surface and the dimensions of the pores by the same authors (4, 8).

Impurities such as iron- and copper salts have an influence on the catalytic activity (7–9). Addition of ammonia and iodine may considerably increase the oxidation rate on active carbons (7).

Puri, Kumar and Kalra (10) showed a relation between the presence of unsaturated sites on a carbon surface and catalytic activity.

Prettre and Sion (3) concluded from their

experiments on alumina that SO_2 is an intermediate and that the formation of SO_2 from H_2S is the rate determining step. This explains the absence of SO_2 in the gas stream leaving the reactor. As the reaction proceeds the smaller pores are filled with sulfur and catalyst surface is lost; the catalyst remains, however, almost equally active as the sulfur-free catalyst. From this observation Prettre and Sion concluded that sulfur is a catalyst and that the chemical nature of the catalyst surface plays a secondary role in this reaction.

Sreeramamurthy (11), on the other hand, concluded from his observations that the sulfur deposited in the catalyst (active carbon from coconut shells) had no catalytic activity.

These conflicting views on the mechanism induced us to investigate this reaction, which is very important for desulfurization of effluent gas streams.

EXPERIMENTAL METHODS

Catalysts

Table 1 lists the four catalysts used, with properties relating to their pore structure. The BET surface area was measured at -196°C , with argon as adsorbate. Macro- and micropore volumes were obtained by combining data from pycnometry and mercury porosimetry at 20°C .

Active carbon (AKH) was prepared from saccharose. Norit RBWI is an industrial active carbon prepared from peat.

Thermobalance

The balance used was a Stanton thermobalance. The catalyst was present on a disk (diam, 1.2 cm), the number of catalyst lay-

ers was maximally three. There is no doubt that there exists a channelling effect around the disk. When, however, high gas flow rates (500–1000 ml/min) and small amounts of catalyst (25–100 mg) are used, the catalyst bed is gradientless in spite of this channelling effect. This may be concluded from the fact that conversions in a small fixed bed and in the thermobalance are equal under the same conditions. For the fixed-bed experiments it was shown experimentally and by calculation that mass transfer limitations were absent. If the reaction temperature does not exceed 200°C , all the sulfur formed by the reaction deposits on the catalyst, because the vapor pressure of the sulfur is diminished by at least a factor of 1000 by the deposition in the tiny pores of the porous material. From the weight increase per unit of time the oxidation rate can be derived. The off gases were not analyzed; the concentrations of H_2S and O_2 in the catalyst layer were practically equal to their concentrations in the feed, because the maximum conversion of H_2S was in all experiments less than 5%.

Fixed-Bed Reactor

Experiments were performed in the apparatus shown in Fig. 1. This reactor (i.d. 6 cm) contained 1 dm^3 of glass beads with an external surface area of 3 m^2 . In this reactor we examined the activity of a liquid sulfur surface, formed by condensation of sulfur vapor on glass beads. This reactor and furnace were interchangeable with a reactor tube (i.d. 0.5 cm) surrounded by a fluidized bed as a heating device. In this case 100–1000 mg of catalyst were present.

TABLE 1
CATALYST PROPERTIES

Catalyst	BET area (m^2/g)	Macropore vol $40 < r < 75,000 \text{ cm}^3/\text{g}$	Micropore vol $3 < r < 40 \text{ \AA cm}^3/\text{g}$
Active carbon (AKH)	980	0.09	0.44
Active carbon (Norit RBWI)	950	0.50	0.33
Molsieve 13X (Union Carbide)	470	0.40	0.21
$\gamma\text{-Al}_2\text{O}_3$ (Ketjen)	213	0.53	0.15

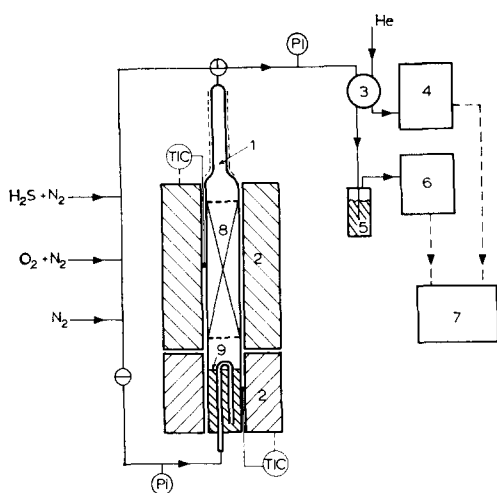

FIG. 1. Fixed-bed apparatus: (1) reactor; (2) furnaces; (3) sampling valve; (4) gas chromatograph (Becker 417); (5) NaOH solution for absorption of H_2S ; (6) oxygen meter; (7) double-signal recorder; (8) filling of glass beads; (9) liquid sulfur; (---) heated line.

Analysis

All the reactants, except sulfur, were analyzed quantitatively:

a. N_2 , H_2S and H_2O were analyzed gas-chromatographically. The column (i.d. 6.35 mm) was filled with 1.8 m Porapak Q coated with 1/4% Triton X305, followed by 1.8 m Teflon 6 coated with 5% Carbowax 1500. The column temperature was 125°C and the carrier flow was 60 ml He/min (12). The time required for a complete analysis was 6 min.

b. O_2 was analyzed continuously with an oxygen meter (Teledyne Model 311). This meter contains a microfuel cell which enables one to measure concentrations from 1 to 210,000 ppm (air).

RESULTS

The Influence of Sulfur Deposition on the Catalytic Activity

For a series of active carbons (prepared from saccharose), Norit RBWI (washed with diluted acid to remove iron oxide) and molecular sieve 13X, we observed that the oxidation rate of H_2S shows a maximum as a function of the amount of sulfur deposited in the pores. Figure 2 shows, as a typical example, the oxidation rate measured with the thermobalance as a function of the amount of sulfur adsorbed on a carbon (AKH) catalyst. A typical experiment with the fixed-bed reactor is shown in Fig. 3, where the oxidation rate of H_2S and the consumption rate of O_2 are plotted versus sulfur in the molecular sieve 13X catalyst.

Figure 4 shows the BET surface area as a function of the amount of sulfur in the pores of Norit. Capillary condensation of argon in micropores of active carbon is the reason for the fact that the values for the surface areas may not be interpreted as exposed surface area. In the case of active carbons these values are good approximations for the micropore volume. Table 2 gives the pore volumes measured with

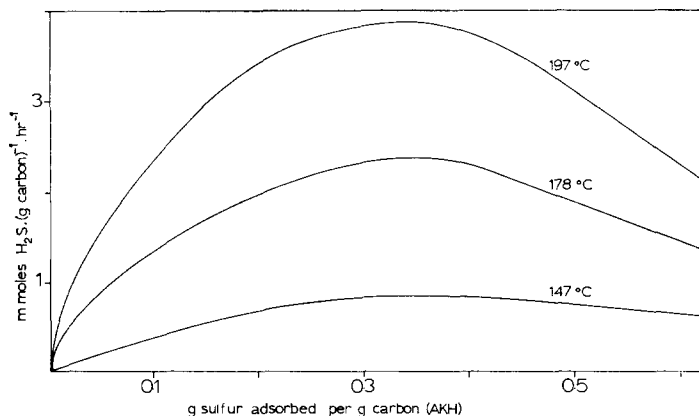

FIG. 2. Oxidation rate of H_2S as a function of the amount of sulfur in the pores of active carbon (AKH). Feed: 0.50 vol% H_2S , 0.50 vol% O_2 , 99 vol% N_2 ; 50 mg catalyst.

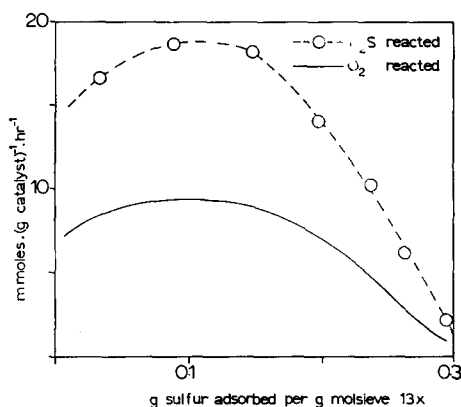

FIG. 3. Activity of molecular sieve 13 X as a function of the amount of sulfur in the pores. Feed: 0.56 vol% H₂S, 0.49 vol% O₂; T = 132°C; 160 mg catalyst.

methanol (molecular diam, 3 Å) and with silicone-fluid 702 (diam, 12 Å) as a function of the sulfur content of the catalyst (13). The results show that sulfur deposits preferentially in the pores with a diameter smaller than 12 Å.

The Catalytic Activity of a Surface of Liquid Sulfur

The catalytic activity of sulfur on a glass surface was examined in the reactor

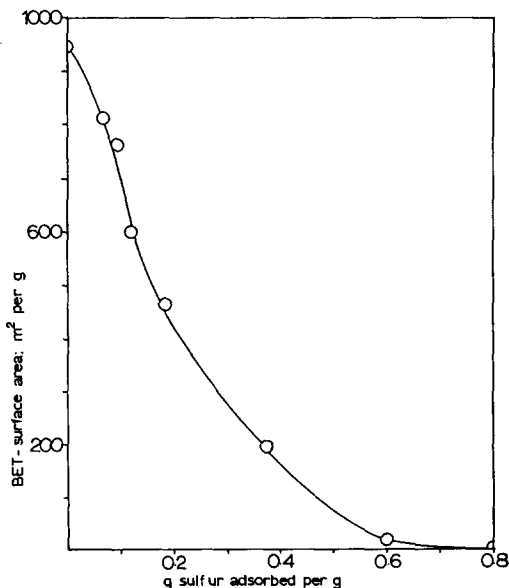

FIG. 4. BET surface area of Norit RBW as a function of the amount of sulfur deposited in the micropores.

TABLE 2
APPARENT PORE VOLUMES MEASURED WITH
METHANOL AND SILICONE-FLUID 702

Sulfur (g/g Norit)	Methanol (cm ³ /g Norit)	Silicone-fluid (cm ³ /g Norit)	Density of deposited sulfur (g/cm ³)
0	0.83	0.68	—
0.11	0.77	0.68	1.8
0.21	0.70	0.65	1.6
0.33	0.65	0.59	1.8
0.44	0.56	0.56	1.6

illustrated in Fig. 1. It was ascertained that the glass surface had no catalytic activity and oxidation in the gas phase was negligible at temperatures below 250°C. Reaction conditions were equal to the 197°C experiment of Fig. 2. We observed that about 10% of the hydrogen sulfide (i.e., 0.01 mmol/min) was converted to sulfur and water by analyzing the water content and the decrease of the concentrations of O₂ and H₂S (SO₂ was absent). This proves that sulfur is a catalyst for the selective hydrogen sulfide oxidation. In comparison with the activity of sulfur trapped in microporous materials, the activity per gram of the sulfur bed is rather low. The explanation for this is the low surface area of maximum 3 m² for sulfur on the glass beads.

Influence of Iron Oxide on the Catalyst Activity

Active carbons used for industrial H₂S oxidation are often impregnated with iron oxide (9). We observed that small amounts of iron oxide (0.2%) can raise the initial oxidation rate to such an extent that the maximum in the rate disappears. In Fig. 5 the oxidation rate of H₂S is plotted versus the sulfur content of the catalyst for a series of active carbons containing different amounts of iron oxide. The commercial carbon Norit does not give a maximum in the oxidation rate as a function of sulfur in the catalyst, but when 80% of the iron oxide is washed out with dilute sulfuric acid a maximum appears. In accordance with this fact the initial activity of an iron-

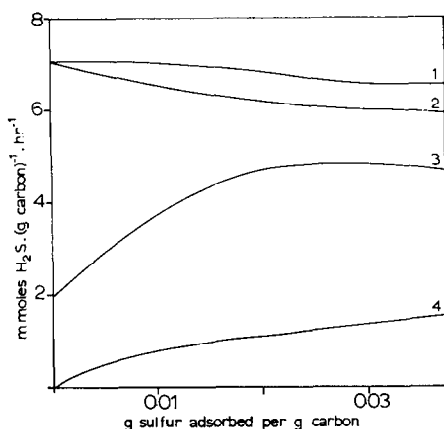

FIG. 5. Influence of iron oxide on the initial oxidation rate of H_2S on active carbon. Measurements in the thermobalance. Feed: 0.50 vol% H_2S , 0.50 vol% O_2 , $T = 197^\circ C$; 50 mg catalyst; (1) AKH-1.90% Fe; (2) Norit RBWI-0.24% Fe; (3) Norit RBWI-0.04% Fe; (4) AKH-0.000% Fe.

free carbon (AKH) increases very much when it is impregnated with iron oxide. The activity of catalysts rich in iron oxide diminishes on progressive covering of the iron oxide with sulfur because the activity of the sulfur surface formed is small compared to the initial iron oxide surface.

DISCUSSION

Sulfur as a Catalyst

The selectivity towards sulfur is more than 90% in all our experiments: the formation of sulfur dioxide and sulfate on the catalyst is negligible. This is in accordance with the observation that more than 95% of the sulfur condensed in the pores of active carbon can be removed by extraction with CS_2 .

Addition of excess water to the feed did not change the conversion of H_2S on an active carbon catalyst at $150^\circ C$. An activation of the catalyst surface by oxygen or hydrogen sulfide is ruled out because a pretreatment of the catalyst with oxygen or hydrogen sulfide did not change the initial activity.

Former investigators (2-5) never observed an increase of the oxidation rate with increasing initial sulfur content of a catalyst. This may be explained by the

fact that commercial products practically always contain iron oxide, and as Fig. 5 demonstrates the presence of even traces of iron oxide makes the observation of a maximum in the oxidation rate impossible. The ratio of the initial rate to the maximum rate for the molecular sieve is rather large compared with that for carbons (cf. Figs. 2 and 3). This will be due to the presence of iron oxide in the clay binder of the molecular sieve.

H_2S oxidation being a very fast reaction, it is very probable that in several cases mass-transfer limitations may hamper the observation of a maximum. Calculation of mass-transfer in the pores and in a film around a catalyst particle showed that mass-transfer limitations are absent in our experiments (Figs. 2 and 3). Moreover, experiments with a variable particle diameter of the catalyst demonstrated the absence of any influence of pore diffusion. The strong increase of the oxidation rate caused by impregnation of active carbon with iron oxide (Fig. 5) demonstrates also the absence of a large influence of film diffusion for an iron-free catalyst.

The strong decrease of the BET surface area of a catalyst (Norit carbon) during reaction (Fig. 2) indicates that the sulfur deposits in the micropores. The BET surface area becomes vanishingly small when the catalyst contains more than 0.6 g S/g carbon. The density of sulfur being 2 g/cm³, this corresponds with 0.3 cm³ S/g carbon. This is in good accordance with the measured micropore volume of this catalyst: 0.33 cm³/g (Table 1). The calculated densities (1.6-1.8 g/cm³) are not much smaller than the density of sulfur at room temperature (Table 2). The same densities are found for active carbon (AKH); also here the densities are not influenced by the size of filled pores. This means that no pore entrances are blocked with sulfur.

Independently of the reaction conditions, the maximum oxidation rate on active carbon (AKH) occurs when about half the micropore volume is filled with sulfur (Table 1 and Fig. 2). In the initial stage of the reaction the sulfur surface will increase, but when the micropores become completely filled with sulfur, the sulfur surface

will decrease. This implies that the sulfur surface goes through a maximum during the reaction. We are not yet able to measure the sulfur surface area, but investigations on this point are continuing.

From the results discussed above it is clear that sulfur acts as a catalyst for the oxidation of H_2S . An indication of the catalytic function of sulfur may be seen in literature data which report that several catalysts do not lose their activity when they retain large quantities of sulfur (up to 75% of the micropores filled with sulfur) (3, 5, 14). Another indication is the similarity of the kinetics of the reaction on catalysts of different chemical nature. From our kinetic measurements we calculated a reaction order of 0.5 in H_2S for active carbon. Prettre and Sion (3) found the same order on an alumina catalyst. Moreover, the activation energy calculated for the reaction on active carbon at maximum activity (Fig. 2) is the same as found by Prettre and Sion on Al_2O_3 , namely, about 35 kJ mol⁻¹.

It seems very likely that sulfur not only has catalytic properties in the liquid state but also at temperatures below the melting point. However, this may be obscured by the condensation of water. Moreover, the distinction between the liquid and the solid state of sulfur adsorbed in pores of molecular diameter is meaningless.

From the literature it is known that there are various reactions which may be catalyzed by sulfur trapped in microporous materials. For instance, zeolites containing sulfur are very active catalysts for *n*-hexane cracking (15). Adams and Jennings (16) observed that a catalyst did not lose its activity for ethyl benzene dehydrogenation when the pores were filled with coke and sulfur.

The Mechanism of the Catalysis by Sulfur

Barrer and Whiteman (17) and Dudzik and Preston (18) examined the trapping of sulfur from the vapor phase in the micropores (4–10 Å) of molecular sieves. From ESR measurements they concluded that the sulfur is present as long-chain biradicals. These biradicals can catalyze cracking re-

actions and it is likely that the same species catalyze the oxidation reaction of H_2S .

We made some preliminary ESR measurements on the catalytic function of sulfur trapped in the pores of γ -alumina at 150°C. A signal found at *g*-values 2.045, 2.027 and 2.004 can be attributed to polysulfur biradicals (18, 19). In the absence of H_2S , the ESR signal disappears when molecular oxygen is present, indicating that O_2 reacts with the sulfur radicals. A radical mechanism is in accordance with the low value for the activation energy of 35 kJ mol⁻¹. The chemisorbed oxygen will react with gas-phase or chemisorbed H_2S . The experimental observation of 0.5 order in H_2S points to chemisorbed H_2S . According to the literature the adsorption of H_2S on sulfur may in fact be a reaction to form polysulfides (H_2S_x , $x > 2$) (20, 21). It is likely that the 0.5 order in H_2S is caused by the fact that the oxidation rate is proportional to the concentration of SH-groups (polysulfide). The mechanism may be connected with the reaction of adsorbed oxygen with the hydrogen of these SH-groups on the surface.

To obtain a clear view of the mechanism of the reaction catalyzed by sulfur we are studying the kinetics in more detail and we shall report on these investigations in the near future.

CONCLUSIONS

1. The oxidation of hydrogen sulfide with oxygen is catalyzed by liquid sulfur at temperatures over 130°C. The catalytic activity of various microporous materials may in fact be caused by sulfur trapped in micropores. The close relations between the degree of micropore filling and catalytic activity indicates that materials containing pores with a radius in the neighborhood of 10 Å are good catalysts. This is in contrast with the conclusion of Swinarski and Siedlewski (4) that the reaction is not catalyzed in pores of active carbon smaller than 35 Å in diameter.

2. Iron oxide is a catalyst for H_2S oxidation and if present in porous materials it makes the observation of a catalysis by sulfur difficult.

3. From some preliminary ESR mea-

surements it is clear that sulfur radicals play a role in the chemisorption of oxygen.

ACKNOWLEDGMENTS

We thank W. Bandsma, P. Koopman and A. Peppelenbos for carrying out part of the experimental work. The investigations were supported by the Dutch Organization for Pure Research (ZWO).

REFERENCES

1. CHATTERJEE, A. R., BHATTACHARYYA, N. B., AND SEN, S. P., *Technology* **8**, 48 (1971).
2. GAMSON, B. W., AND ELKINS, R. H., *Chem. Eng. Progr.* **49**, 203, No. 4 (1953).
3. PRETTRE, M., AND SION, R., *Z. Elektrochem.* **63**, 100 (1959).
4. SWINARSKI, A., AND SIEDLEWSKI, J., *Actes Congr. Int. Catal., 2nd, 1960* **2**, 2345 (1961).
5. KERR, G. T., AND JOHNSON, G. C., *J. Phys. Chem.* **64**, 381 (1960).
6. HYNE, J. B., *Oil Gas J.* **70**, 64 (1972).
7. STORP, K., *Dechema Monogr.* **64**, 91 (1971).
8. SWINARSKI, A., SIEDLEWSKI, J., AND ROZWADOWSKI, M., *Ann. Gen. Chim. Congr. Int. Soufre, Toulouse* **3**, 102 (1967).
9. FISCHER, F., AND KRAUS, H., *Chem. Ing. Tech.* **36**, 963 (1964).
10. PURI, B. R., KUMAR, G., AND KALRA, K. C., *Indian J. Chem.* **9**, 970 (1971).
11. SREERAMAMURTHY, P., PhD thesis, Andhra Univ., 1972.
12. COOK, W. G., AND ROSS, R. A., *Anal. Chem.* **44**, 641 (1972).
13. BOND, R. L., "Porous Carbon Solids." Academic Press, London, 1967.
14. ANON., *Oil Gas J.* **65**, Nov. 27 (1967).
15. MIALE, J. N., AND WEISZ, P. B., *J. Catal.* **20**, 288 (1971).
16. ADAMS, C. R., AND JENNINGS, T. J., *J. Catal.* **17**, 157 (1970).
17. BARRER, R. M., AND WHITEMAN, J. L., *J. Chem. Soc., Ser. A* **13** (1967).
18. DUDZIK, Z., AND PRESTON, K. F., *J. Colloid Interface Sci.* **26**, 374 (1968).
19. KONINGSBERGER, D., PhD thesis, T. H. Eindhoven, 1971.
20. WIEWIOROWSKI, T. K., *Endeavour* **29**, 11 (1970).
21. GOLYLAND, S. M., KRAPIVINA, T. K., AND LAZAREV, V. I., *Russ. J. Phys. Chem.* **36**, 700 (1962).