

## APPLICATION OF FLEXIBLE MULTIBODY MODELLING FOR CONTROL SYNTHESIS IN MECHATRONICS

**R.G.K.M. Aarts\***, **J. van Dijk\***, **D.M. Brouwer\*<sup>†</sup>** and **J.B. Jonker\***

\*Laboratory of Mechanical Automation and Mechatronics, Faculty of Engineering Technology  
University of Twente, P.O. Box 217, 7500 AE Enschede, The Netherlands  
e-mails: R.G.K.M.Aarts@utwente.nl, J.vanDijk@utwente.nl,  
D.M.Brouwer@utwente.nl, J.B.Jonker@utwente.nl,  
web page: <http://www.wa.ctw.utwente.nl/>

<sup>†</sup>Demcon Advanced Mechatronics, Oldenzaal, The Netherlands

**Keywords:** Flexible multibody modelling, Mechatronic design, Compliant mechanism.

**Abstract.** *The models used in the conceptual phase of the mechatronic design should not be too complicated, yet they should capture the dominant system behaviour. This includes the computation of natural frequencies and mode shapes in a relevant frequency range. For the control system synthesis the low frequent behaviour up to the cross-over frequency needs to be known. Furthermore, the closed-loop system can be unstable due to parasitic modes at somewhat higher frequencies.*

*In this paper we demonstrate the applicability of a multibody modelling approach based on non-linear finite elements for the mechatronic design of a compliant six DOF manipulator. A kinematic analysis is applied to investigate the exact constrained design of the system. From dynamic models the natural frequencies and mode shapes are predicted and a state-space model is derived that describes the system's input-output relations. The models have been verified with experimental identification and closed-loop motion experiments. The predicted lowest natural frequencies and closed-loop performance agree sufficiently well with the experimental data.*

## 1 INTRODUCTION

In high precision equipment the use of compliant mechanisms is favourable as elastic joints offer the advantages of no friction and no backlash. For the conceptual design of such mechanisms there is no need for very detailed and complex models that are time-consuming to analyse. Nevertheless the models should capture the dominant system behaviour which must include relevant three-dimensional motion and geometric non-linearities, in particular when the system undergoes large deflections. More specifically, we distinguish two phases in the modelling approach of which a kinematic design is the first phase. Typical design considerations for this phase aim at avoiding overconstrained or underconstrained design in line with so-called Exact Constraint Design principles [1, 2, 3]. The dynamic system performance is considered in the second design phase. It involves the computation of the natural frequencies and the accompanying mode shapes, which are closely related to the required closed-loop bandwidth and stability of the mechatronic system [4, 5].

In [6, 7] we discussed the use of the SPACAR software for these design phases. It offers a multibody approach based on non-linear finite elements. The sound inclusion of the non-linear effects at the element level [8] appears to be very advantageous. Only a rather small number of elastic beam elements is needed to model e.g. wire flexures and leaf springs accurately. In particular for the kinematic analysis to check the constraints only a single flexible beam element is used for each flexure. In a dynamic analysis the natural frequencies are computed and more beam elements may be used to obtain more accurate results at higher frequencies or for larger deflections. The non-linear model can be linearised in a number of configurations throughout the complete operational range of the mechanism to obtain a series of locally linearised models in terms of the independent degrees of freedom, e.g. state space models for control system design [9]. Numerically efficient models are obtained as the number of independent degrees of freedom is rather small. Consequently, the approach is particularly well suited during the early (mechatronic) design phase, where time consuming computations would severely hamper the design progress.

In this paper the modelling approach will be applied for the analysis and MIMO control system synthesis of a parallel kinematic precision manipulator with six kinematic degrees of freedom (DOF) as is described in the next section. Numerical results are presented in Sect. 3 and are verified with experimental data. Finally conclusions are drawn.

## 2 SIX DOF MANIPULATOR

Figure (1) shows a six DOF hexapod-like flexure-based manipulator [10]. It is a scaled-up version of a micromanipulator originally designed to be manufactured with MEMS technology. It has to translate and rotate the end effector in all directions. It is difficult to accurately measure the motion of the small micromanipulator which is not more than a few mm in size. Sensors can be integrated much easier in the scaled-up manipulator which has a largest outer dimension of 540 mm. The large version should give insight in the dynamic behaviour of the micromanipulator and therefore the restrictions resulting from the MEMS fabrication method have been preserved.

In the scaled-up manipulator six voice coil actuators (VCMs) are applied to drive the position and orientation of the end effector. A straight guidance assures that the motion of each VCM is exactly in one in-plane direction. Each VCM is equipped with a contact-free optical incremental encoder to measure the actuator displacement for colocated feedback control. The motions of a pair of VCMs are transferred via in-plane leaf springs to an intermediate body, such that this

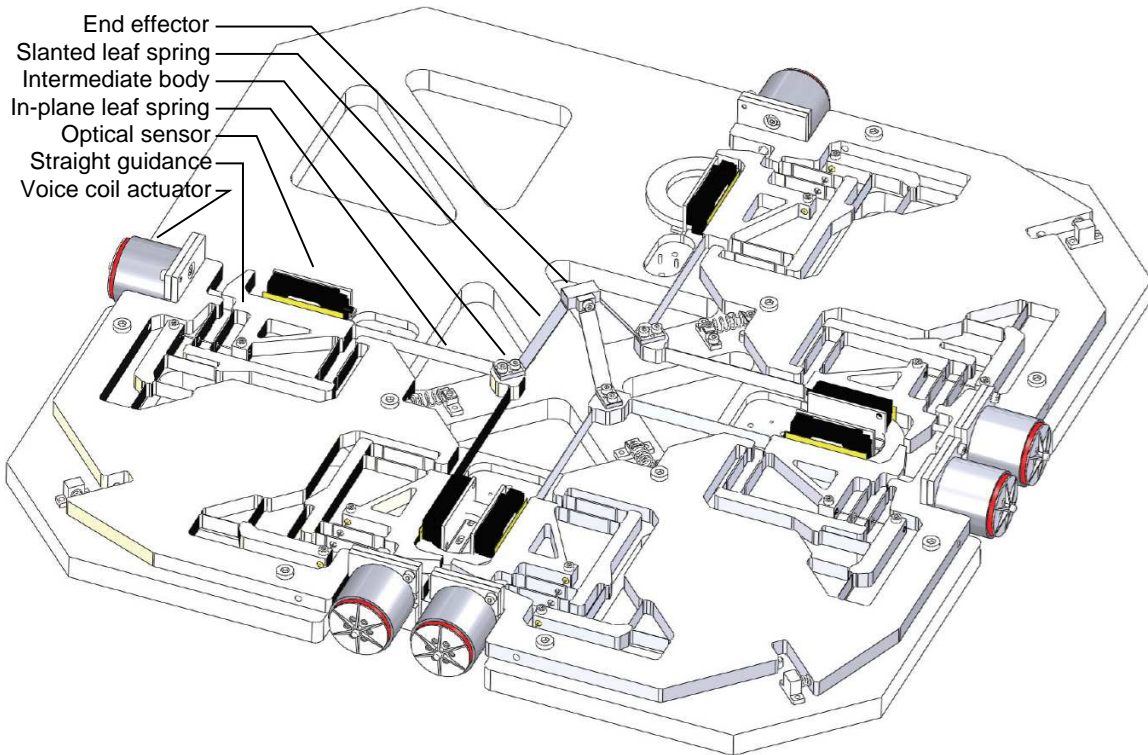

Figure 1: Six DOF hexapod-like manipulator with flexible joints [10].

body can move in the in-plane directions. In total three of these intermediate bodies support three slanted leaf springs that are connected to the end effector. In this way the three times two in-plane actuated translations of the intermediate bodies enable translations and rotations of the end effector in all six DOF. E.g. the horizontal translations of the end effector are realised with identical motions of all three intermediate bodies. To accomplish a vertical translation of the end effector, the three intermediate bodies move radially towards the centre of the set-up. These motions and the rotations are outlined in more detail by Brouwer *et al* [10]. In general, the relations between the linear VCM displacements and the position and orientation of the end effector are highly non-linear. These relations can be measured with a sensor system that is mounted on the end effector. This sensor system (not shown in Fig. (1)) includes an optical sensor to measure the displacement in one long-stroke direction, while the parasitic displacements in the perpendicular directions and the rotations are measured with capacitive sensors.

### 3 NUMERICAL MODELLING

A numerical model of the manipulator needs to account for the flexures in the system. More specifically each straight guidance consists of leaf springs and a wire spring. The end effector is mounted on the three slanted leaf springs. In the modelling approach implemented in SPACAR flexible beam elements are used for all flexures.

The location of the beam element is described by the positions of the end nodes  $p$  and  $q$ , as well as their orientations. Essential is the definition of physically meaningful deformation modes of the element that are invariant for rigid body motions of the element. As there are twelve independent nodal coordinates and six rigid body degrees of freedom, six independent deformation modes can be defined. For the spatial flexible beam one deformation mode coor-

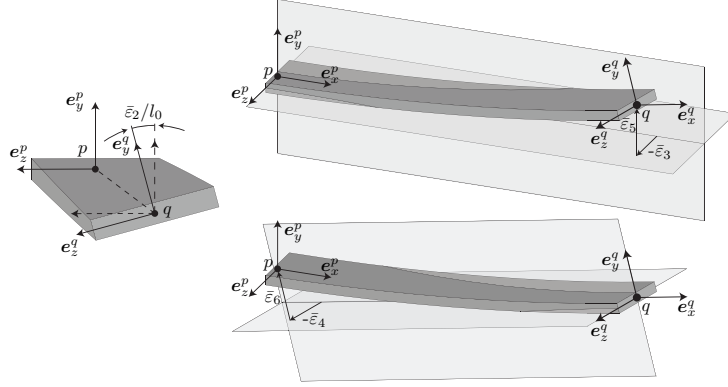

Figure 2: Deformations  $\varepsilon_2$ - $\varepsilon_6$  of the spatial beam element (reprinted from [12]).

dinate  $\varepsilon_1$  is taken to describe the elongation,  $\varepsilon_2$  for torsion and four modes  $\varepsilon_3$ - $\varepsilon_6$  for the bending deformations of the element [8, 11]. Figure (2) illustrates five of these deformation modes. The deformation mode coordinates are defined in such a way that geometrically non-linear effects due to interaction between deformation modes are included. Consequently, accurate models can be obtained with a relatively small numbers of elements even for the case when large deflections are considered [8, 11]. Each of the deformation mode coordinates can be defined to be constrained or released. If a deformation mode coordinate is released, i.e. not constrained, constitutive equations have to be specified for the stress resultants, which are the dual to the deformations. These constitutive equations may express simply linear elastic behaviour based on the element stiffness properties.

Numerical models of the system can be made with a varying level of complexity. With a *kinematic* SPACAR model it can be verified that the manipulator satisfies exact constraint design. In this model each wire flexure and leaf spring is modelled with a single flexible beam element. All deformation modes with a high stiffness are considered to be rigid, i.e. having constrained deformation mode coordinates. The deformation modes with low stiffnesses are allowed to deform. Then it appears that a Jacobian matrix can be assembled which must be square and full rank in order to satisfy exact constraint design: otherwise the system is underconstrained and/or overconstrained [7]. The straight guidances of the manipulator are overconstrained by design to increase the stiffness in the out-of-plane direction. This is confirmed in the kinematic analysis and these parts are manufactured accurately to minimise the internal stresses [10]. The six DOF kinematic model confirms the exact constraint design of the end effector motion. Note that for this kinematic analysis the masses and stiffnesses do not play a role.

Natural frequencies and mode shapes are obtained from *dynamic* models. The simplest dynamic model is derived from the kinematic model outlined above in which mass and stiffness properties are added. In the applied modelling approach the non-linear equations of motion can be linearised in any valid configuration of the system. From the mass and stiffness matrices the (configuration dependent) natural frequencies and mode shapes are computed. A state space model is derived after defining the system's inputs, the VCM forces, and outputs, the colocated sensor positions. As the simplest dynamic model has six DOF, only the six lowest natural frequencies of the manipulator can be obtained from this model and a twelfth order state space model is found.

Mode	870-DOF	237-DOF	Mode	Exp.
1	59.3	59.3	1	55.3
2	59.9	59.9	2	56.0
3	84.3	84.5	3	79.6
4	86.8	86.8	4	83.0
5	122.0	122.2	5	116.1
6	124.6	125.1	6	120.2
			7	225
			8	285
7	658	697	9	565
8	844	917		
9	908	1001	10	1050
10	1074	1303		

Table 1: First ten natural frequencies (in rad/s) of the large and reduced models as well as the experimentally identified natural frequencies.

For control system synthesis also higher natural frequencies and their mode shapes must be known [5]. These so-called parasitic modes involve deformations in the directions of the larger stiffnesses. In the dynamic model they can be accounted for by releasing deformation mode coordinates associated with deformations in these directions. In the previous six DOF model these deformations were prescribed zero and now these released deformation mode coordinates give rise to additional degrees of freedom. Furthermore, the system should be evaluated in configurations throughout the manipulator's workspace. The six deformation modes of the flexible beam element offer only an accurate approximation for a limited set of element deformations. If more complex deformations are expected, the approximation can be improved by increasing the number of elements in each flexure. Obviously, both improvements of the dynamic model result in an increased number of DOF.

For the considered manipulator a model has been made in which three or four beam elements are used for each wire flexure of leaf spring. This model has 870 DOF which result in many natural frequencies that are far outside the frequency range of interest. To reduce the number of DOF the model is first simplified by reducing the number of beam elements that is used for the flexures. If the lower natural frequencies of the reduced order model are identical or close to the natural frequencies of the 870-DOF model in this range, the simplification is accepted. In this way the number of DOF could be reduced to 420. A further simplification is possible by constraining deformations. The longitudinal stiffness of the flexures is rather high and it appears that a model with all elongations  $\varepsilon_1$  prescribed zero results in 315 DOF without loss of accuracy. Similarly also part of the bending deformation modes with a high stiffness can be considered rigid and finally a 237-DOF model is obtained. Table (1) lists the numerical values of the ten lowest natural frequencies of both the extended 870-DOF and the reduced 237-DOF models. As can be seen in the table the lowest six natural frequencies of the reduced model are almost identical to the natural frequencies of the large model. For the higher natural frequencies somewhat larger differences are found. For the control system synthesis, in particular the seventh natural frequency is relevant which differs by about 6%. In Fig. (3) these natural frequencies can be recognised as the peaks in the graph of the system's singular values or principal gains as functions of the frequency. In this analysis the VCM forces are the system's inputs and the colocated sensors are the outputs. The lowest natural frequencies are damped due to the

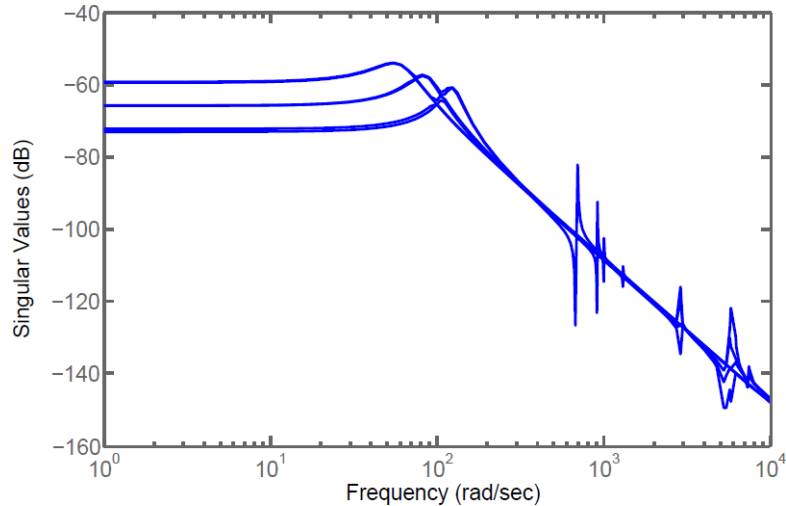

Figure 3: Singular values of the transfer matrix of the 237-DOF SPACAR-model near the equilibrium configuration (from [13]).

actuator's back-EMF.

The linearised models of the mechanical system are well-suited for control system synthesis. The following steps are taken. At first the cross-over frequency of the feedback controller is determined from performance requirements. Assuming this cross-over frequency will be well below the unwanted higher natural frequencies, the closed-loop performance can be evaluated from the controller combined with the low frequent behaviour of the mechanical system [5], i.e. the six lowest natural frequencies. For this purpose a linearised six DOF model that accounts for the lowest six natural frequencies in Table (1) is well-suited. As an example we consider a PID-like feedback controller that should track a third order motion profile during 1 s with an error of less than 0.1% of the amplitude. This can be accomplished with a cross-over frequency of about 300 rad/s. Secondly, the closed-loop performance can be improved with feedforward control. A feedforward control input can be computed by applying a stable inverse approximation of a low frequent model of the mechanical system to the desired motion profile.

Finally the robust stability of this closed-loop system can be evaluated. In particular the first parasitic natural frequency may violate stability requirements in an  $\mathcal{H}_\infty$  controller design strategy [5]. Obviously for this purpose a model of the mechanical system like the 237-DOF model is needed that is sufficiently accurate above the cross-over frequency. This model can also be used in closed-loop simulations to validate the controller design.

#### 4 EXPERIMENTAL RESULTS

An experimental set-up with the manipulator of Fig. 1 has been realised. As outlined in Sect. 2 it is actuated with six VCMs. Colocated sensors measure the actuator displacements. MIMO system identification has been carried out with a black-box multivariable output error subspace (MOESP) subspace model identification method [13, 14, 15]. A 21<sup>th</sup> order model is found that identifies the lowest natural frequencies as well as the first parasitic modes. These natural frequencies are included in Table (1) and are combined with the 237-DOF model in Fig. (4). It appears that the six lowest natural frequencies agree quite well between the numerical model and experimental data. Also the natural frequency of the first parasitic mode agrees

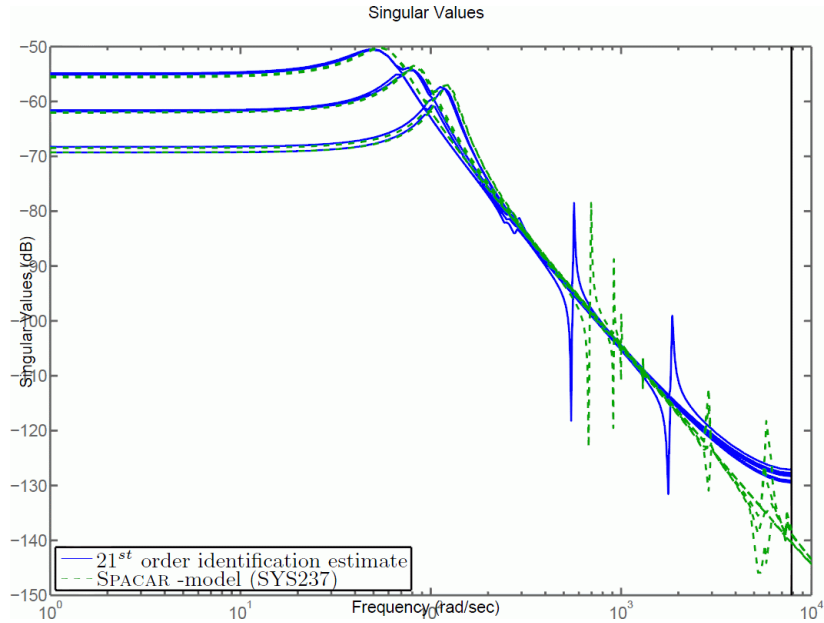

Figure 4: Singular values of the transfer matrix of the 21<sup>th</sup> order identification estimate and the SPACAR-model near the equilibrium configuration (from [13]).

reasonably well. However, two additional natural frequencies are found in the identification that are not included in the models. Probably these modes arise from suspension modes of the frame that are not accounted for in the numerical models. In Fig. (4) these modes are visible, but their amplitudes are rather small. Overall it is concluded that the numerical models provide an adequate prediction of the experimental results.

The designed feedback and feedforward controller has been tested for a motion of the end effector of 6 mm displacements in the horizontal  $x,y$ -plane. Figure 5 shows the tracking error of the actuator displacements during this motion. It appears that they remain below the desired 0.1% although the signal is quite noisy. This is to a large extent caused by a 50 Hz disturbance from the mains.

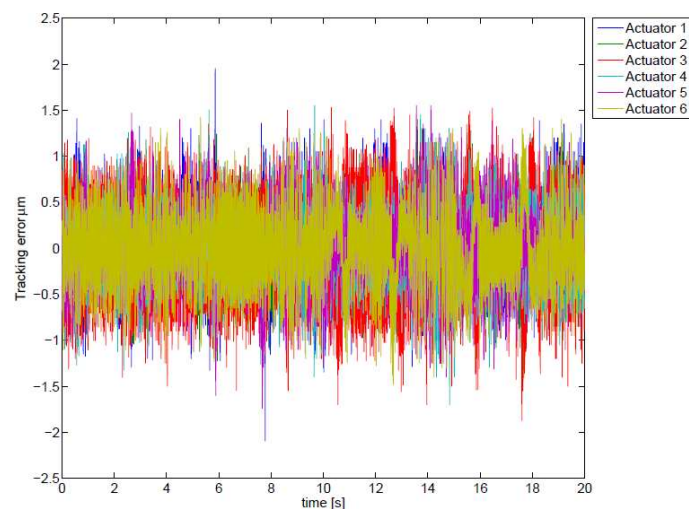

Figure 5: Measured tracking error of the actuator displacements during a 6 mm displacement of the end effector in the  $X,y$ -plane (from [13]).

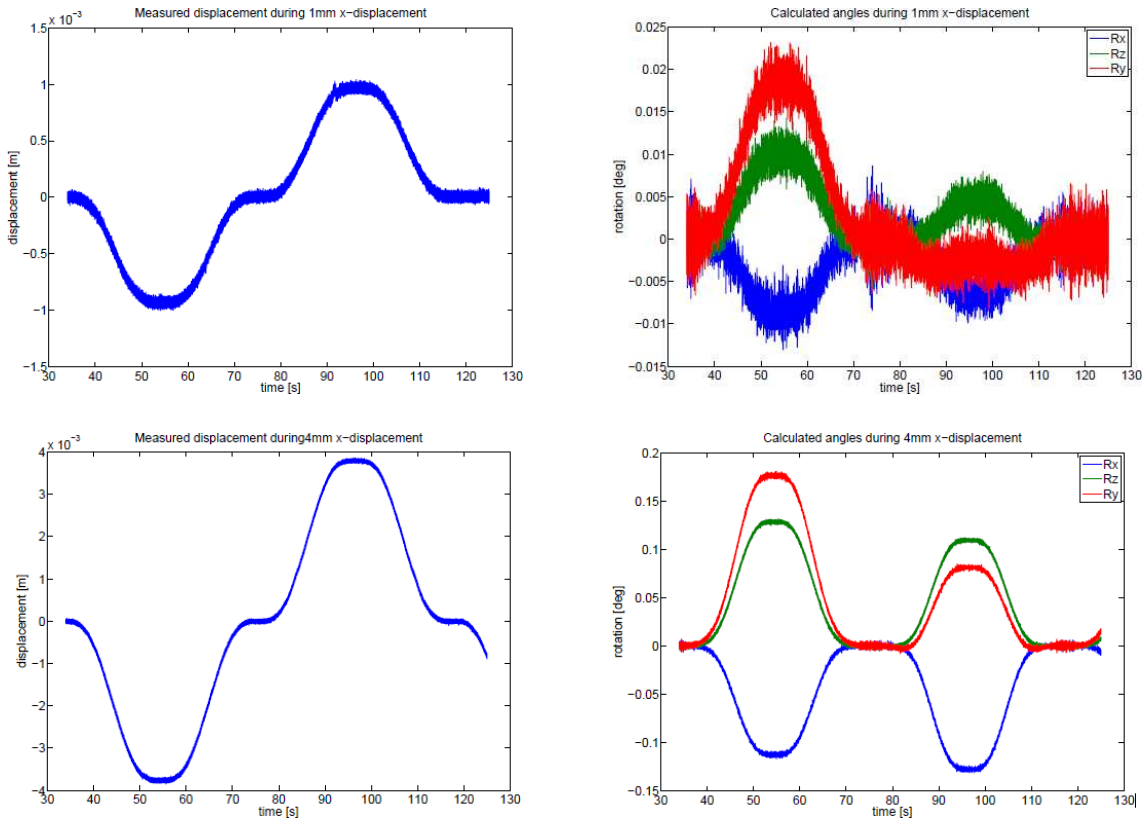

Figure 6: Measurements of the end effector motion during 1 mm (top) and 4 mm (bottom)  $x$ -displacements of the end effector. The left graphs show the long stroke motion in the  $x$  direction; the right graphs show all three rotations of the end effector for both displacements (from [13]).

Finally, the motion of the end effector has been analysed with the sensor mounted on the end effector. This sensor can measure a long stroke in one direction and small deviations in the other directions as well as rotations. The  $x$  axis of the coordinate system is aligned with the direction of the long stroke. The linearised manipulator model has been used to compute the actuator displacements needed for linear displacements of the end effector in the  $x$  direction of 1 mm and 4 mm, respectively. Figure (6) shows the actually measured motion of end effector. It is found that the real displacement matches reasonably with the intended motion, but it is somewhat smaller than expected. Furthermore, unwanted rotations are observed. To some extent both effects can be caused by a small misalignment between the coordinate systems of the manipulator and the sensor. However, it is also noted that the deviations increase more than linearly when the amplitude of the end effector displacement is increased. This could be caused by the non-linear behaviour of the manipulator which is not yet included in the model currently used to compute the needed actuator displacements.

## 5 CONCLUSIONS

The design of a mechatronic system of the six DOF compliant manipulator in Fig. (1) demonstrates the proposed modelling approach for this purpose. The formulation is based on a non-linear finite element description for flexible multibody systems. The flexible beam elements account for geometric nonlinear effects such as geometric stiffening and interaction between deformation modes. Flexible joints like wire flexures and leaf springs can be modelled ade-



quately using only a few number of flexible beam elements. In this way, a rather low dimensional system description can be obtained which includes the non-linear behaviour that occurs at large deflections.

In a kinematic analysis only a single flexible beam element is used for each flexure and the exact constrained design of the system is examined. For the dynamic analysis a maximum of four flexible beam elements is used for each flexure. The number of DOF is reduced by prescribing deformations with high stiffness and in rigid parts to be zero. The modelling approach is well suited for mechatronic design, i.e. the mechanical design as well as control system synthesis.

## ACKNOWLEDGEMENTS

The authors acknowledge the contributions from Martijn Huijts and Sytze Spijksma in the design, analysis and testing of the manipulator.

## REFERENCES

- [1] D.L. Blanding. *Exact Constraint: Machine Design Using Kinematic Principles*. ASME Press, New York, 1999.
- [2] L.C. Hale. *Principles and Techniques for Designing Precision Machines*. Ph.D. Thesis, University of California, Livermore, California, 1999.
- [3] H.M.J.R. Soemers. *Design Principles for Precision Mechanisms*. T-point print, Enschede, The Netherlands, 2010.
- [4] Xu JianXin. *New lead compensator designs for control education and engineering*. 27<sup>th</sup> Chinese Control Conference, 16–18 July 2008.
- [5] J. van Dijk, R.G.K.M. Aarts and J.B. Jonker. Frequency domain framework for mechatronic design of motion systems. To be published, 2011.
- [6] R.G.K.M. Aarts, J. van Dijk and J.B. Jonker. *Efficient analyses for the mechatronic design of mechanisms with flexible joints undergoing large deformations*. ECCOMAS Thematic Conference Multibody Dynamics 2009, Warsaw University of Technology, June 29 – July 2, 2009.
- [7] R.G.K.M. Aarts, J. van Dijk and J.B. Jonker. *Flexible multibody modelling for the mechatronic design of compliant mechanisms*. The 1<sup>st</sup> Joint International Conference on Multibody System Dynamics, Lappeenranta, Finland, May 25–27, 2010,
- [8] J.B. Jonker and J.P. Meijaard. *Definition of deformation parameters for the beam element and their use in flexible multibody system analysis*. ECCOMAS Thematic Conference Multibody Dynamics 2009, Warsaw University of Technology, June 29 – July 2, 2009.
- [9] J.B. Jonker, R.G.K.M. Aarts and J. van Dijk. A linearized input-output representation of flexible multibody systems for control synthesis. *Multibody System Dynamics*, **21** (2), 99–122, 2009.
- [10] D.M. Brouwer, B.R. de Jong and H.M.J.R. Soemers. Design and modeling of a six DOF's MEMS-based precision manipulator. *Precision Engineering*, **34** (2), 307–319, 2010.

- [11] J.P. Meijaard, D.M. Brouwer, and J.B. Jonker. Analytical and experimental investigation of a parallel leaf spring guidance. *Multibody System Dynamics*, **23**(1), 77–97, 2010.
- [12] S.E. Boer, R.G.K.M. Aarts, D.M. Brouwer, and J.B. Jonker. *Multibody modelling and optimization of a curved hinge flexure*. The 1<sup>st</sup> Joint International Conference on Multibody System Dynamics, Lappeenranta, Finland, May 25–27, 2010,
- [13] S.A. Spijksma, *Analysis and MIMO control of a 6 DOFs parallel kinematic precision manipulator*. M.Sc. thesis, Report number Wa-1293, University of Twente, Enschede, December 2010.
- [14] G. Nijssen, *A subspace based approach to the design, implementation and validation of algorithms for active vibration isolation control*. PhD thesis, University of Twente, Enschede, The Netherlands, 2006.
- [15] P. van Overschee and B. de Moor. N4SID: Subspace algorithms for the identification of combined deterministic-stochastic systems. *Automatica*, **30** (1), 75–93, 1994.