

Efficient XeF($C \rightarrow A$) Laser Excited by a Coaxial Electron Beam at Intermediate Pumping Rates

PETER J. PETERS, HERBERT M. J. BASTIAENS, W. J. WITTEMAN,
ROLAND SAUERBREY, MEMBER, IEEE, C. BRENT DANE, AND
FRANK K. TITTEL, FELLOW, IEEE

Abstract—XeF($C \rightarrow A$) laser radiation has been produced in a five-component gas mixture excited by a coaxial electron beam with an intermediate pulse length (~ 175 ns) and pumping rate (~ 1 MW/cm³). The laser output energy was 215 mJ from an active volume of 157 cm³ (1.4 J/L) at a total gas pressure of 8 bar corresponding to an intrinsic efficiency of 0.3%.

INTRODUCTION

THE first electron beam or discharge excited XeF lasers operated on the 351 nm XeF($B \rightarrow X$) transition of the XeF molecule because the cross section for stimulated emission for this transition is more than one order of magnitude larger than the one for the XeF($C \rightarrow A$) transition. The XeF($C \rightarrow A$) transition is characterized by a broad-band emission spectrum centered around 480 nm in the blue-green spectral region. Early demonstrations of laser emission from this transition used three-component gas mixtures as is common for most excimer systems, which resulted in a relatively inefficient XeF($C \rightarrow A$) laser. Since 1983, however, significant progress has been made by Nighan *et al.* using a superior five-component gas mixture [1], [2]. With these improvements the XeF($C \rightarrow A$) laser performance approaches that of the $B \rightarrow X$ excimer system. The kinetic properties were also studied in detail by Nighan *et al.* [3] and the predicted results agreed well with the experimental results, indicating that the major formation and absorption processes are reasonably well understood.

In most investigations concerning the XeF($C \rightarrow A$) laser, short pulse, high current density electron beams have been used to excite the laser gas. Injection control of these systems has been used to tune the laser wavelength and to narrow the bandwidth, and to significantly enhance the laser output energy to the ~ 1 J level with a specific energy of 1.5 J/L [4], [5]. On the other hand, recently an electron beam pulse of 700 ns pulse duration

with a moderate pump rate of 250 kWcm⁻³ was used by Mandl *et al.* [6] to excite the same five-components laser gas mixture, previously shown to yield optimal results by Nighan *et al.* [2]. A XeF($C \rightarrow A$) laser pulse width of 400 ns and a specific energy of 1.25 J/L were reported under low-pressure (1.6 atm) excitation conditions [6]. For short (~ 10 ns) excitation pulses, the XeF($C \rightarrow A$) operates after termination of the pumping pulse in the afterglow and efficient energy extraction results from injection control. In the long pumping pulse quasi-CW regime the XeF($C \rightarrow A$) gain is very low (~ 0.005 cm⁻¹) which leads to long laser ring up times (~ 300 ns) in a stable cavity [6]. Kinetic modeling indicates that an intermediate pumping regime with excitation pulse length on the order ~ 100 ns and pumping powers of about 1 MWcm⁻³ may offer an interesting compromise between the short pulse and long pulse pumping conditions considered earlier [3]. Therefore, in this paper we describe experiments carried out with an electron-beam apparatus that produced pump pulses with an intermediate pulse length of about 175 ns (FWHM) and a power deposition rate on the order of 1 MWcm³. Moreover, we will present initial measurements with gas mixtures in which part of the Ar is replaced by Ne as a buffer gas. The lower stopping power of Ne could be compensated for by using a higher gas pressure because of the fact that our system could be pressurized to a total gas pressure of 10 bar. It was found in earlier experiments with other excimers (ArF, KrF) that the variation of the buffer gas may have important consequences on the optimum pressure regime, total output energy, and kinetics [7]. Moreover, useful information can be gained for discharge excited systems, although the ionic channel dominates the electron-beam excitation kinetics.

EXPERIMENTAL CONFIGURATION

To excite the laser gas, a five-stage Marx generator connected directly to a coaxially-shaped vacuum diode was used. The anode was a thin-walled (50 μ m) titanium tube with an inner diameter of 20 mm which contained the laser gas mixture. The construction of the tube allowed the system to be pressurized up to 10 bar for several hundreds of shots without a tube failure. The cathode was a cylindrical metal tube with an inner diameter of 128 mm.

Manuscript received November 17, 1989; revised February 23, 1990. This work was supported by the Dutch Stichting FOM, the Office of Naval Research, the National Science Foundation, and the Welch Foundation.

P. J. Peters, H. M. J. Bastiaens, and W. J. Witteman are with the Department of Applied Physics, University of Twente, 7500 AE Enschede, The Netherlands.

R. Sauerbrey, C. B. Dane, and F. K. Tittel are with the Department of Electrical and Computer Engineering, Rice University, Houston, TX 77251.

IEEE Log Number 9037365.

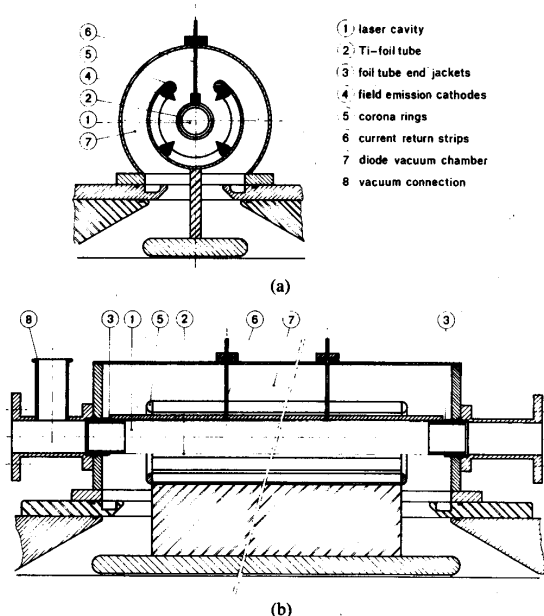

Fig. 1. Transverse (a) and longitudinal (b) cross section of the coaxial electron beam diode and the laser chamber.

On the innerside four solid graphite edge-shaped profiles each of 50 cm length were mounted. Cross sections of the coaxial diode structure are shown in Fig. 1. The apparatus is described in detail in [8]. The pulse length of the electron beam in the diode was about 250 ns (FWHM) at a maximum peak diode voltage of 275 kV and peak current of 27.5 kA. The estimated peak current density in the laser cell was about 100 A/cm². This was confirmed by the power deposition calculations from the stopping power tables which agreed with the values obtained from the energy deposition measurements by the pressure jump technique. Due to the stopping power of the titanium tube wall, the laser current pulse width inside the anode tube is about 175 ns (FWHM). This was concluded from fluorescence measurements on this device. An example of such a fluorescence signal of the XeF(*B* → *X*) transition is shown in Fig. 4.

The optical cavity was formed by two dielectric mirrors separated by 80 cm. The radius of curvature of the first mirror was 10 m, with a reflectivity of 99.8% at 485 ± 20 nm and a transmission of more than 90% at 350 nm. The other mirror was plane-plane and was coated with a dielectric stack with a reflectivity of 85% at 485 ± 20 nm and a transmission of more than 90% at 350 nm. All optics were protected by an Al₂O₃ overlay to minimize fluoride damage of the dielectric coatings.

The laser output beam passed through a color glass filter (GG 385) and was detected by a GenTec ED 500 energy meter. The reflected signal from the color glass filter was used to monitor the temporal shape of the output pulse. It was detected after appropriate attenuation by

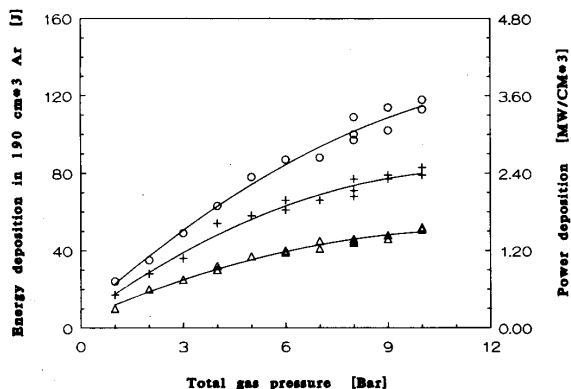

Fig. 2. Energy deposition as a function of the total gas pressure for various load voltages of the Marx generator (Δ : 80 kV, +: 90 kV, \circ : 100 kV; volume: 190 cm³; gas mixture 3% HCl and 97% Ar).

neutral density filters, a diffuser, and a 485 ± 10 nm broad-band interference filter by a vacuum photodiode (ITL TF 1850).

EXPERIMENTAL RESULTS AND DISCUSSION

In order to estimate the intrinsic efficiency, the energy deposition of the electron beam in the gas mixture contained in the laser cell was determined. In Fig. 2 the results are shown for different load voltages of the Marx generator as measured by the pressure jump technique. The values depicted have been obtained with a gas mixture containing 3% HCl and 97% Ar. HCl was added in order to suppress energy loss through Ar₂ emission. The peak energy depositions are reached at the maximum pressure of 10 bar and correspond to 605, 420, and 220 J/L for charging voltages of 100, 90, and 80 kV respectively. At 8 atm Ar and 100 kV charging voltage the deposited energy is 540 J/L, which corresponds to pumping power of about 3.1 MWcm⁻³.

Previous experiments had shown that a 6% Kr concentration in the laser gas mixture is optimum for maximum energy output from the XeF(*C* → *A*) laser [2]. Recent experiments with short electron beam pulse excitation suggested that a higher Kr concentration of about 25% might be preferable [5]. Initial measurements of the laser output energy under the present pumping conditions showed that a five-component laser gas mixture containing 24% of Kr resulted in lower laser output levels compared to a mixture containing 6.1% of Kr. In Fig. 3 the output energy is plotted as a function of the total gas pressure containing 0.02% F₂, 0.16% NF₃, 0.18% Xe, 6.1% Kr, and 93.5% Ar. The maximum output energy of 215 mJ (1.4 J/L, intrinsic efficiency: 0.26%) was obtained at a total gas pressure of 8 bar. For a higher gas pressure the output energy decreased although the pump rate increased further. For the lower pump rate (90 kV Marx load voltage) the output energy began to saturate at a total gas pressure of 7 bar. Energy measurements with and without the color glass filter showed no detectable emission at

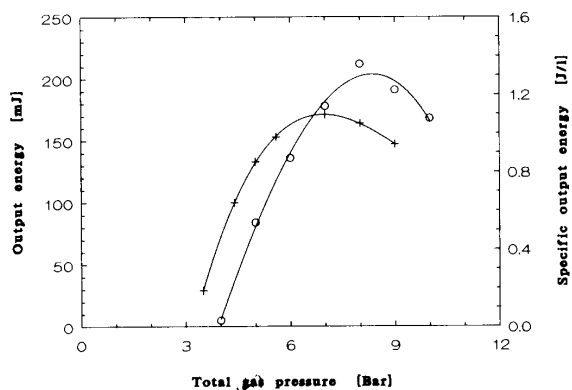

Fig. 3. XeF(C → A) output energy as a function of the total gas pressure for two different load voltages (+: 90 kV, O: 100 kV; active volume: 157 cm³).

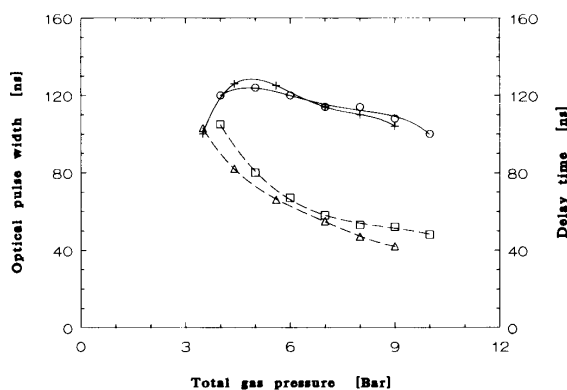

Fig. 5. Optical pulse width (solid line) and delay time (dashed line) as a function of the total laser gas pressure for two different load voltages (+, □: 90 kV, O, Δ: 100 kV).

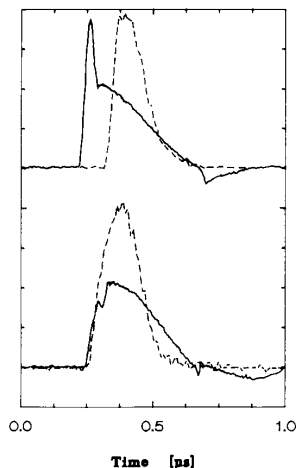

Fig. 4. Upper part: Electron beam diode voltage (solid line) and temporal development of the laser output pulse (dashed line). Lower part: Current pulse (solid line) and XeF(C → A) fluorescence signal (dashed line); charging voltage 90 kV; total gas pressure: 5 bar.

either 351 nm, the XeF(B → X) transition, or the KrF transition at 248 nm. There is some spread in the output energy values measured under the same conditions. For this reason, a fresh gas mixture was used for each shot.

In Fig. 4, a typical set of time dependent signals is plotted (charging voltage: 90 kV; total gas pressure: 5 bar). In the upper part of the figure the voltage is shown (solid line) together with the laser output pulse (dashed line). In the lower part the current (solid line) and a fluorescence signal (dashed line) are plotted as a function of time. The fluorescence signal shown here is a XeF(C → A) signal measured by a photomultiplier with a suitable neutral density and bandpass filter. The signal was measured from a pumped length of 0.5 cm. They started at the same time as the current signal and showed the same width as the XeF(B → X) signals. Fluorescence signals from the entire pumping length showed considerable narrowing to a

pulse length of ~50 ns (FWHM) due to amplified spontaneous emission. The delay time or optical ring-up time is the time difference between the onset of the current (and fluorescence signal) and the laser output signal. Fig. 5 shows the delay time and the width of the laser pulses as a function of gas pressure. The delay times show a considerable decrease with increasing gas pressures. At low gas pressures (~3 bar) the gain is small due to the low pumping density which causes a relatively long ring-up time of about 95 ns in the stable resonator. At higher pumping densities, i.e., higher gain coefficients, the ring-up time decreases to 40 ns. The temporal laser pulse width is almost pressure independent. The longest pulse of about 130 ns was seen at a low pressure, while for 10 bar a value of 100 ns was measured.

Calculations for this system were performed based on an analytical model for injection controlled excimer laser amplifiers [9]. Since the gain coefficient under the present pumping conditions was not known, it was inferred from the laser output energy. This yielded a value of ~0.01 cm⁻¹ under optimum pumping conditions at 8 bar. If this gain coefficient is assumed the calculated laser pulse width and delay times are in good agreement with the experimental values (Fig. 5). The predicted optimum reflectivity for the output coupler is between 90% and 95% rather than at 85% which was used in anticipation of a higher gain for the present experiments. With optimized cavity conditions energy outputs of ~400 mJ are predicted.

Experiments were also conducted with the same gas mixture in which 50% of the Ar buffer gas was replaced by Ne. The results of the measurements with 50% Ne are plotted in Figs. 6 and 7. The output energy under these conditions was lower, but there was little change in the shape of the curves. The optical delay times were about 30 ns longer compared to the gas mixtures with only Ar as a buffer gas. A comparison of the pulse widths shows that the pressure dependence for the Ne-Ar mixture was smaller than for the Ar buffered mixture. Especially in the low-pressure gas mixtures, the combination of a longer

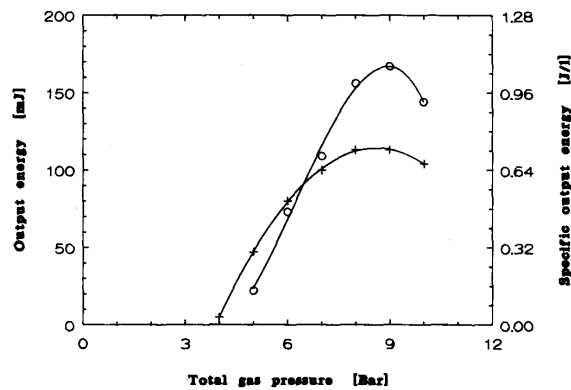

Fig. 6. Same as Fig. 3, but in the laser gas mixture 50% of the Ar is replaced by Ne.

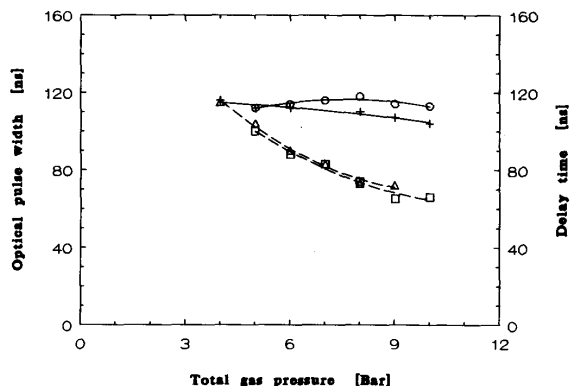

Fig. 7. Same as Fig. 5 with 50% Ne instead of Ar.

delay time and a shorter pulse width accounted for the lower output energy values. We could not obtain a high laser fluence from a laser gas mixture containing 75% Ne, probably due to degradation of the optics.

In conclusion, we have shown that the XeF($C \rightarrow A$) laser can also be operated successfully in the intermediate electron beam pumping regime. In order to obtain an output energy of ~ 1.4 J/L, it was not necessary to use injection control. On the other hand, with injection control the output energy should increase, especially at low pressure, due to a decrease laser ring-up time. The system was not optimized with respect to the laser gas mixture and the output mirror reflectivity. Moreover, all results have been obtained with a titanium anode tube with a wall thickness of 50 μm . By changing to a 25 μm tube, the pumping rate can be increased considerably and even better results can be achieved with this XeF($C \rightarrow A$) excimer laser system.

REFERENCES

- [1] W. L. Nighan, Y. Nachshon, F. K. Tittel, and W. L. Wilson, "Optimization of electrically excited XeF($C \rightarrow A$) laser performance," *Appl. Phys. Lett.*, vol. 42, p. 1006, 1983.

- [2] W. L. Nighan, F. K. Tittel, W. L. Wilson, N. Nishida, Y. Zhu, and R. Sauerbrey, "Synthesis of rare gas halide mixtures resulting in efficient XeF($C \rightarrow A$) laser oscillation," *Appl. Phys. Lett.*, vol. 45, p. 947, 1984.
- [3] W. L. Nighan and M. C. Fowler, "Kinetic processes in electron beam excited XeF($C \rightarrow A$) laser media," *IEEE J. Quantum Electron.*, vol. 25, p. 791, 1989.
- [4] N. Hamada, R. Sauerbrey, W. L. Wilson, F. K. Tittel, and W. L. Nighan, "Performance characteristics of an injection controlled electron beam pumped XeF($C \rightarrow A$) laser system," *IEEE J. Quantum Electron.*, vol. 24, p. 1571, 1988.
- [5] G. J. Hirst, C. B. Dane, W. L. Wilson, R. Sauerbrey, F. K. Tittel, and W. L. Nighan, "Scaling of an injection-controlled XeF($C \rightarrow A$) laser pumped by a repetitively pulsed, high current density electron beam," *Appl. Phys. Lett.*, vol. 54, p. 1851, 1989.
- [6] A. Mandl and L. H. Litzemberger, "Efficient, long pulse XeF($C \rightarrow A$) laser at moderate electron beam pump rate," *Appl. Phys. Lett.*, vol. 53, p. 1690, 1988.
- [7] P. J. M. Peters, I. H. T. Fierkens, and W. J. Witteman, "Effect of Ne and Ar on the performance of a high pressure ArF* laser pumped by a small coaxial electron beam," *Appl. Phys. Lett.*, vol. 51, p. 883, 1987.
- [8] P. J. M. Peters, H. M. J. Bastiaens, and W. J. Witteman, "A study of the electron quenching of excimers in a KrF* laser excited by a coaxial electron beam," *Appl. Phys.*, vol. B-43, p. 253, 1987.
- [9] N. Hamada, R. Sauerbrey, and F. K. Tittel, "Analytical model for injection-controlled excimer laser amplifiers," *IEEE J. Quantum Electron.*, vol. 24, p. 2458, 1988.



Peter J. Peters was born in Meerlo, The Netherlands on November 5, 1945. He received the M.S. degree from the Catholic University of Nijmegen in 1975 and the Ph.D. degree in 1981 from the University of Twente, Enschede, The Netherlands, all in physics.

In 1981 he joined the staff of the Quantum Electronics Group. He is now an Associate Professor with the University of Twente and has conducted research on TEA CO discharge lasers, various excimer lasers, and atomic rare-gas lasers.



Herbert M. J. Bastiaens was born in Rimborg, The Netherlands on August 31, 1959. He received the diploma in technical physical engineering in 1981.

Since 1981 he has been with the Quantum Electronics Group, Faculty of Applied Physics, University of Twente, Enschede, The Netherlands, where he has been involved in research on electron beam pumped gas lasers.

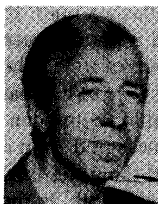

W. J. Witteman was born in Monster, The Netherlands, on December 12, 1933. He received the degree of Mechanical Engineer from the Technical University of Delft, Delft, The Netherlands, in 1958, the Ph.D. degree in physics from the Technical University of Eindhoven, Eindhoven, The Netherlands in 1963.

He was Postdoctoral Fellow from 1958 to 1959 and a Research Associate from 1959 to 1960 with the Institute for Fluid Dynamics and Applied Mathematics, University of Maryland, College Park, MD, where he was engaged in shock tube research and molecular relaxation phenomena. From 1961 to 1969 he was with Philips Research

ries, Eindhoven, The Netherlands, and participated in high-pressure physics and laser physics. Since 1969 he has been a professor with the University of Twente in laser physics, where he is currently engaged in high-power molecular lasers (CO₂ systems, excimer lasers, electroionization lasers) and free-electron lasers.

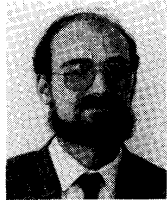

Roland Sauerbrey (M'85) was born in Coburg, Germany, in 1952. He received the M.S. and the Ph.D. degrees, both in physics, from the University of Würzburg, Würzburg, Germany, in 1978 and 1981, respectively.

After a year as a postdoctoral fellow with Rice University, Houston, TX, he returned to the University of Würzburg, where he became an Assistant Professor with the Department of Physics. In 1985 he joined the faculty of Rice University where he is presently an Associate Professor with

the Department of Electrical and Computer Engineering. His primary research activities have been in the areas of short wavelength lasers, excimer spectroscopy, and laser applications.

Dr. Sauerbrey is a member of the American Optical Society, the American Physical Society and the German Physical Society.



C. Brent Dane was born in Dalhart, TX, on August 8, 1961. He received the B.S. degree in chemistry and mathematics from Wayland Baptist University, Plainview, TX, in 1983 and the M.A. and Ph.D. degrees in physical chemistry from Rice University, Houston, TX, in 1986 and 1987, respectively.

From January 1988 to May 1990, he was a research associate with the Department of Electrical and Computer Engineering, Rice University. He is presently a staff physicist in the Laser Programs Division at Lawrence Livermore National Laboratories, Livermore, CA. His primary research activities have been in the development of tunable laser systems in the visible and infrared and their applications in spectroscopy and the study of chemical kinetics.

Dr. Dane is a member of Optical Society of America and Sigma Xi.

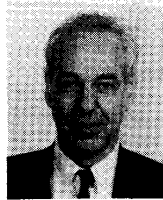

Frank K. Tittel (SM'72-F'86) was born in Berlin, Germany, in 1933. He received the M.A. and Ph.D. degrees from Oxford University, Oxford, England.

From 1959 to 1967 he was a Research Physicist with the General Electric Research and Development Center, Schenectady, NY. Since 1967 he has been with Rice University, Houston, TX, where he is a Professor with the Department of Electrical and Computer Engineering. His research interests include laser devices, laser spectroscopy, and nonlinear optics.

Dr. Tittel is a Fellow of the Optical Society of America and a member of the IEEE Laser and Electro-Optics Society and the American Physical Society.